

# Foot Control AFC - 45

## OPERATION MANUAL

Thank you for purchasing Foot Control AFC - 45. This Foot Control is designed for use connecting to the Air Line Kit (AL - H1207F). Read this and all the associated component Operation Manuals carefully before use. Always keep this Operation Manual in a place where a user can refer to for reference at any time.

### 1. CAUTIONS FOR HANDLING AND OPERATION

- Read these warnings and cautions carefully and only use in the manner intended.
- These warnings and cautions are intended to avoid potential hazards that could result in personal injury to the operator or damage to the device. These are classified as follows in accordance with the seriousness of the risk.

| Class          | Degree of Risk  |
|----------------|---|
| <b>WARNING</b> | <b>A safety hazard could result in bodily injury or damage to the device if the safety instructions are not properly followed.</b>        |
| <b>CAUTION</b> | <b>A hazard that could result in light or moderate bodily injury or damage to the device if the safety instructions are not followed.</b> |

#### WARNING

- ① Connect hose securely to avoid accidental disconnection during use.
- ② Stop Air supply before connecting the Air Hose.
- ③ Do not exceed 0.6MPa for air hose pressure. Turn counterclockwise the adjusting knob of the Filter Regulator of the Air Line Kit (sold separately) then adjust the air pressure to below 0.6MPa.
- ④ Do not place the air hose near heat sources.

#### CAUTION

- ① Do not drop or hit this Foot Control.
- ② Do not use or store the air hose in a bent state.
- ③ About connection, operation and cautions of Air Line Kit (AL - H1207F), refer to "Air Line Kit Operation Manual" carefully before use.

### 2. FEATURES

- ① Designed to depress from any direction.
- ② Fine adjustment of speed control is possible.

### 3. SPECIFICATIONS AND DIMENSIONS

#### 3 - 1 Specifications

|                            |               |
|----------------------------|---------------|
| Model                      | AFC - 45      |
| Maximun Operation Pressure | 0.6MPa        |
| Hose Length                | 2m            |
| Pedal Reserve              | Approx. 4.3mm |
| Applicable Air Line Kit    | AL - H1207F   |

|  | Temperature | Humidity                     | Atmospheric Pressure |
|--|-------------|------------------------------|----------------------|
| Operation Environment                  | 0 - 40°C    | MAX.75%<br>(No condensation) | 700 - 1,060hPa       |
| Transportation and Storage Environment | -10 - 50°C  | 10 - 85%                     | 500 - 1,060hPa       |

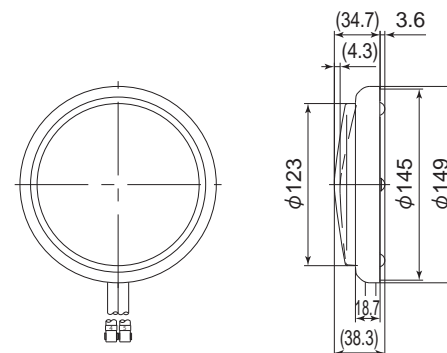

Fig. 1

### 4. SYSTEM CHART

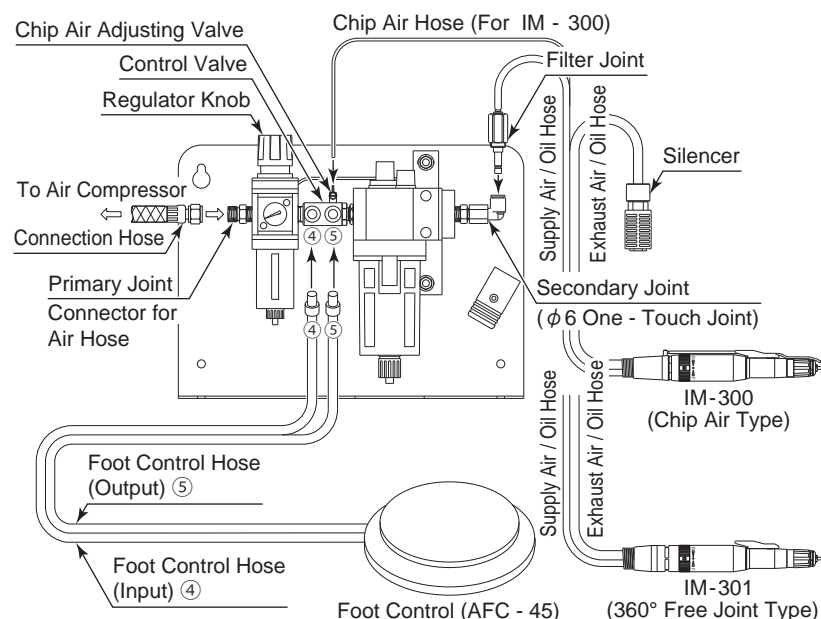

Fig. 2

### 5. CONNECTION OF THE HOSE

#### CAUTION

Hose is connected to Control Valve according to the written number in Control Valve.  
If hose is connected reversely, air flow can not be adjusted.

- ① Connect "Hose No.4 of Foot Controller" to "No.4 of Control Valve".
- ② Connect "Hose No.5 of Foot Controller" to "No.5 of Control Valve", too.

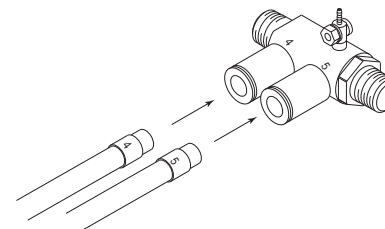

Fig. 3

### 6. DISPOSAL OF THE SPINDLE

When disposal of a Spindle is necessary, follow the instructions from your local government agency for proper disposal of industrial components.