

Long Attachment BMH - 300

OPERATION MANUAL OM-K0104E001

Thank you for purchasing long attachment BMH-300. This attachment designed for cut and grind the bottom surface of deep ribs or holes by unique slim body. The Emax EVOLution <Control Unit>, <Blushless Motor> or ROTUS <Air Motor>, <Air Line Kit> are required to drive this attachment. Read this Operation Manual carefully before use. Also read <Emax EVOLution> or <ROTUS>, <Air Line Kit> Operation Manual.

1. CAUTIONS FOR HANDLING AND OPERATION

- Read these warnings and cautions carefully and only use in the manner intended.
- These warnings and cautions are intended to avoid potential hazards that could result in personal injury or damage to the device. These are classified as follows in accordance with the seriousness of the risk.

Class	Degree of Risk
⚠ WARNING	A safety hazard could result in bodily injury or damage to the device if the safety instructions are not properly followed.
⚠ CAUTION	A hazard that could result in light or moderate bodily injury or damage to the device if the safety instructions are not followed.

⚠ WARNING

- ① This attachment is designed for hand use. Never install this attachment or any hand tool on a machine such as a special purpose machine, NC lathe or mill.
- ② Do not touch the cutting tool while it is rotating. It is very dangerous.
- ③ Always wear safety glasses, dust mask and hearing protection.
- ④ When installing a cutting tool, tighten the collet chuck correctly and recheck the collet chuck before use. Do not overtighten the collet chuck. This may cause damage to the spindle.
- ⑤ Do not use grindstones with an outside diameter over $\phi 17\text{mm}$.
- ⑥ Do not exceed 13mm of overhang for mounted grindstones as shown in Fig. 1. If the overhang must exceed 13mm, reduce the motor speed in accordance with Table 1.
- ⑦ Do not use bent, broken, chipped, out of round or sub-standard tools as they may cause shatter or explode. The cutting tool with cracked, bended may cause some injury to operator. When using a new cutting tool, rotate it in a low speed and increase speed gradually for safety.
- ⑧ Always operate cutting tools within the cutting tool manufacturer's recommended speed limits. Use of a cutting tool higher than the manufacturer's recommended speed limits could cause damage to the spindle and injury to the operator.
- ⑨ Do not apply excessive force. This may cause cutting tool slippage, cutting tool damage, injury to the operator, loss of concentricity and precision.

Table 1. Overhang and Speed

Overhang (mm)	Max. Speed (min ⁻¹)
20	N x 0.5
25	N x 0.3
50	N x 0.1

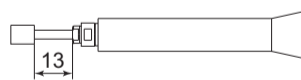

Fig. 1

*N = Max. Operating Speed with 13mm overhang.

⚠ CAUTION

- ① Use less than the maximum allowable motor speed 35,000min⁻¹.
- ② Do not drop or hit this attachment, as shock can cause damage to the internal components.
- ③ Be sure to clean the collet chuck, the spindle taper and threads before replacing the cutting tool. If ground particles or metal chips stick to the inside of spindle or the collet chuck, damage to the collet chuck or spindle can occur due to the loss of precision.
- ④ When cleaning a attachment, stop the motor and remove dirt with a brush or a cloth. Do not blow compressed air into the attachment. Foreign particles or cutting chips may get into the ball bearings.
- ⑤ Always clean the tool shank before installing the tool in the spindle.

⚠ CAUTION

- ⑥ When sizing the correct collet chuck size to the cutting tool shank diameter, a tolerance of +0 ~ -0.01mm is strongly recommended. A cutting tool shank within the +0 ~ -0.1mm range is mountable, however, this may cause poor concentricity and or insufficient cutting tool shank gripping force.
- ⑦ Select suitable products or tools for each application. Do not exceed the capabilities of the attachment or cutting tools.
- ⑧ Keep everything in order not to place the rag which could be caught near the hand tool.
- ⑨ Stop operating immediately when abnormal rotation or any unusual vibrations are observed. Afterwards, please check the content of section 7 " TROUBLESHOOTING ".
- ⑩ Always check if the cutting tool, collet chuck is damaged before and after operating.
- ⑪ If the collet chuck show signs of wear or damage, replace it before a malfunction or additional damage occurs.
- ⑫ No lubrication is required because grease impregnated ball bearings are used.
- ⑬ After repair, initial operation, or long periods of non operational time, please use the following break-in procedure. Start rotating slowly and over a short period of time, then increase the speed gradually until reaching the maximum allowable speed.
- ⑭ Do not disassemble, modify or attempt to repair the attachment. Additional damage will occur to the internal components. Service must be performed by NSK NAKANISHI or an authorized service center.

2. FEATURES

- ① The attachment is ideal for cut and grind the bottom surface of deep ribs or holes.
- ② The tip diameter of attachment is $\phi 13\text{mm}$.
- ③ Various sizes of collet chucks are available CHM 1.0mm - 3.175mm. Standard collet chuck is CHM 3.0mm or CHM 3.175mm. (For U.S. market CHM 3.175mm.)

3. SPECIFICATIONS AND DIMENSIONS

3 - 1 Specifications

Model	BMH - 300		
Maximum Motor Rotation Speed	Less than 35,000min ⁻¹		
Applicable Motor	ENK - 410S · ENK - 250T (Emax EVOLution) IM-300 · IM-301 (ROTUS)		
Vibration Level	Less than 2.5m/s ²		
Noise Level at 1m distance	Less than 70dB (A)		
Weight	156g		

	Temperature	Humidity	Atmospheric Pressure
Operation Environment	0 - 40°C	MAX.75% (No condensation)	700 - 1,060hPa
Transportation and Storage Environment	-10 - + 50°C	10 - 85%	500 - 1,060hPa

Standard Accessories

- Collet Chuck $\phi 3.0\text{mm}$ (CHM - 3.0) or $\phi 3.175\text{mm}$ (CHM - 3.175) ··· 1pc. (For U.S. market $\phi 3.175\text{mm}$ (CHM - 3.175))
- Wrench (7 x 5.1) ··· 1pc.
- Wrench (6 x 4.5) ··· 1pc.
- Pin Wrench (K - 233) ··· 1pc.
- Operation Manual ··· 1set.

※ The collet chuck is attached to the spindle.

< Option >

Collet Chuck (CHM- □□)	$\phi 1.0\text{mm}$, $\phi 1.6\text{mm}$, $\phi 2.0\text{mm}$, $\phi 2.35\text{mm}$, $\phi 3.0\text{mm}$, $\phi 3.175\text{mm}$
------------------------	--

3 - 2 Outside View

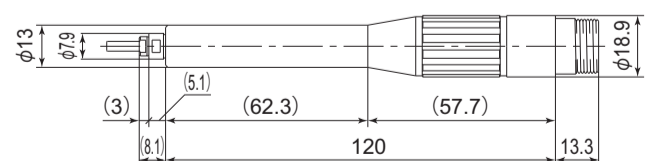

Fig. 2

4. CONNECTION TO THE MOTOR

CAUTION

Make sure your hands and all interlocking parts of the attachment and motor are clean before connecting the motor to the attachment. This is critical to prevent contaminants from entering the motor or attachment.

Align the threads on the front end of the motor and the rear end attachment, and turn the attachment clockwise. If the drive shaft of the motor does not engage the drive dog on the attachment, you may only be able to turn it about 2 turns. DO NOT FORCE IT. Turn the attachment back a few threads, rotate the attachment by hand to engage the drive shaft and the drive dog, and screw them together with a provided pin wrench (K-233).

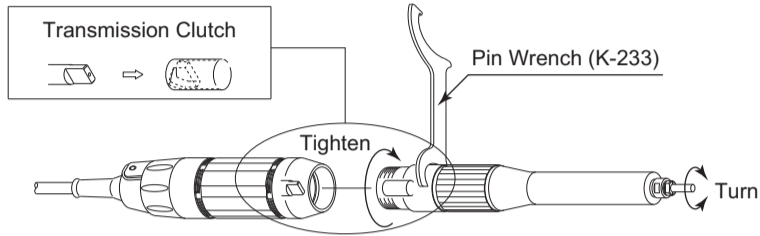

Fig. 3

5. CHANGING THE CUTTING TOOL

CAUTION

Do not tighten the collet chuck without inserting a cutting tool or dummy bur, as this will result in damage to the collet chuck.

- Set the provided 7mm wrench on the spindle.
- Place the provided 4.5mm wrench on the collet chuck and turn it counterclockwise to loosen the collet chuck and remove the cutting tool.
- Clean the collet chuck, then insert the new cutting tool and tighten the collet chuck by turning clockwise. Do not over tighten.

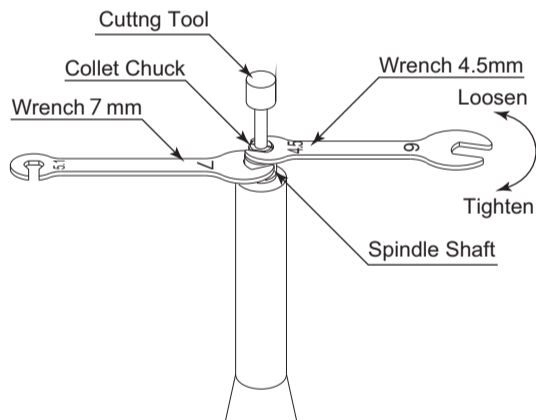

Fig. 4

6. REPLACING THE COLLET CHUCK

- Remove the cutting tool according to the section 5. " CHANGING THE CUTTING TOOL ".
- Hold the spindle with the 7mm wrench and loosen the collet chuck counterclockwise.
- To replace the collet chuck into the spindle, turn it clockwise.

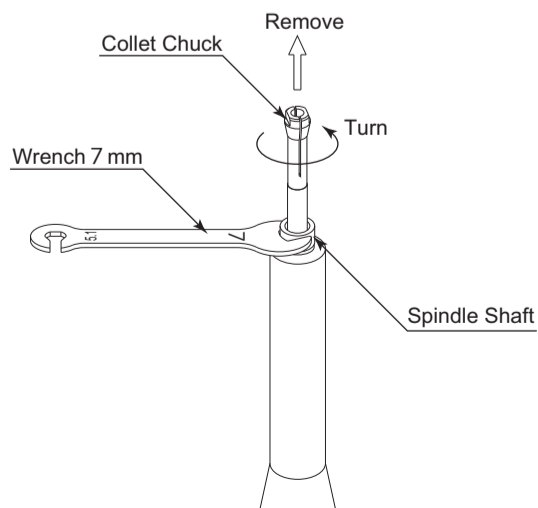

Fig. 5

7. TROUBLESHOOTING

If a problem or concern occurs, please check the following prior to consulting your dealer.

Trouble	Cause	Inspection / Corrective Action
Spindle does not run.	The ball bearings are damaged.	Replace the ball bearings. (Return to NAKANISHI dealer service.)
	Motor is broken.	Replace the motor. (Return to NAKANISHI dealer service.)
Overheating during rotation.	Cutting debris has contaminated the ball bearing, and the ball bearings are damaged.	Replace the ball bearings. (Return to NAKANISHI dealer service.)
Abnormal vibration or noise during rotation.	Using bent cutting tool.	Replace the cutting tool.
	Cutting debris has contaminated the ball bearings. The ball bearings are worn.	Replace the ball bearings. (Return to NAKANISHI dealer service.)
Cutting tool slippage.	Collet chuck is not correctly installed.	Check and clean the collet chuck. Reinstall the collet chuck and re-tighten. Check the accuracy.
	The collet chuck is worn.	Replace the collet chuck.
High run-out.	Bent the cutting tool.	Replace the cutting tool.
	Collet chuck is worn.	Replace the collet chuck.
	Inside of the spindle is worn.	Replace the spindle shaft. (Return to NAKANISHI dealer service.)
	Contaminants inside the collet chuck or the spindle.	Clean the collet chuck and the inside of the spindle.
	The ball bearings are worn.	Replace the ball bearings. (Return to NAKANISHI dealer service.)

8. DISPOSAL OF THE ATTACHMENT

When disposal of an Attachment is necessary, follow the instructions from your local government agency for proper disposal of industrial components.

NAKANISHI INC.

www.nakanishi-inc.com

700 Shimohinata, Kanuma, Tochigi 322-8666, Japan

Contents are subject to change without notice.

NSK America Corp

www.nskamericacorp.com

1800 Global Parkway, Hoffman Estates, IL 60192, USA