

ブラシレスモータスピンドル / Brushless Motor Spindle

BMS-4020-MQL series

BMS-4040-MQL series

取扱説明書 / OPERATION MANUAL

日本語 : P1 - P19 / English : P21 - P40

OM-K0683 001





Thank you for purchasing the Brushless Motor Spindle " BMS-4020-MQL / BMS-4040-MQL series ". This Brushless Motor Spindle is designed for grinding, small diameter drilling and milling, etc. The E4000 CONTROLLER and Air Line Kit are required to drive this Brushless Motor Spindle. Read this and all the associated component Operation Manuals carefully before use. Always keep this Operation Manual in a place where a user can referred to for reference at any time.

CONTENTS

1. CAUTIONS FOR HANDLING AND OPERATION	P21
2. BASIC PACKAGE	P23
3. WARRANTY	P24
4. CONTACT US	P24
5. FEATURES	P24
6. SPECIFICATIONS AND DIMENSIONS	P25
7. CHANGING THE TOOL	P28
8. REPLACING THE COLLET	P29
9. CONNECTION OF MOTOR CORD	P30
10. CONNECTION OF THE COOLANT HOSE OR THE OIL MIST HOSE	P31
11. THE METHODS OF SUPPLYING THE COOLANT OR OIL MIST	P33
12. INSTALLATION OF THE BRUSHLESS MOTOR SPINDLE	P34
13. BREAK-IN PROCEDURE	P37
14. CAUTIONS WHEN USING GRINDSTONES AND TOOLS	P38
15. HOW TO USE ADJUSTER BOLT DEPTH STOP	P39
16. TROUBLESHOOTING	P40
17. DISPOSAL OF THE BRUSHLESS MOTOR SPINDLE	P40

1. CAUTIONS FOR HANDLING AND OPERATION

- Read these warnings and cautions carefully and only use in the manner intended.
- These warnings and cautions are intended to avoid potential hazards that could result in personal injury to the operator or damage to the device. These are classified as follows in accordance with the seriousness of the risk.

Class	Degree of Risk
 WARNING	A safety hazard could result in bodily injury or damage to the device if the safety instructions are not properly followed.
 CAUTION	A hazard that could result in light or moderate bodily injury or damage to the device if the safety instructions are not followed.

WARNING

- ① This Brushless Motor Spindle is not a hand tool. It is designed to be used on CNC machines or special purpose machines.
- ② Do not touch the cutting tool while it is running. It is very dangerous.
- ③ Wear safety glasses, dust mask, and use a protective cover around the Brushless Motor Spindle whenever the Brushless Motor Spindle is rotating.
- ④ Never connect, disconnect or touch the Connector or Motor Cord Plug with wet hands. This may cause an electric shock.
- ⑤ Never operate or handle the Brushless Motor Spindle until you have thoroughly read the Operation Manuals and safe operation has been confirmed.
 - 1) To prevent injuries / damages, check the Brushless Motor Spindle and cutting tool for proper installation, before operating the Motor Spindle.
 - 2) Before disconnecting the Brushless Motor Spindle, always turn the control power off and turn the compressed air supply to the CONTROLLER off. Then it is safe to remove the Brushless Motor Spindle.

WARNING

- ⑥ Whenever installing a Brushless Motor Spindle to a fixed metal base, ensure that the fixed metal base is grounded in order to avoid risk of an electric shock.
- ⑦ When installing a tool, tighten the collet correctly and check again the collet and collet nut before use. Do not over-tighten the collet. This may cause damage to the spindle.
- ⑧ Do not use bent, broken, chipped, out of round or sub-standard tools, as this may cause them to shatter or explode. Tools with fractures or a bent shank will cause injury to the operator. When using a new tool, rotate it in a low speed and increase speed gradually for safety.
- ⑨ Do not exceed the recommended maximum allowable speed of the tool. For your safety, use speeds below the maximum allowable speed.
- ⑩ Do not apply excessive force. This may cause injury to the operator by slippage or damage of the tool, or loss of concentricity and precision of the Brushless Motor Spindle.
- ⑪ When using the coolant, be sure to use a dedicated coolant line . If non-coolant recommended hose is connected, the hose may burst, which may cause injury to the operator.

CAUTION

- ① A coolant or oil mist supply is required when operating this Brushless Motor Spindle.
 - * Never operate this Brushless Motor Spindle in a dry condition when using water based coolant. It will cause internal damage to the Brushless Motor Spindle.

If this Brushless Motor Spindle is being used in a dry cutting condition, always initially supply either oil based coolant or oil mist to the unit. After every 30 minutes of dry operation, oil based coolant or oil mist must be re-introduced to the unit. Never operate this unit for no more than 30 minutes in a dry state. If this Brushless Motor Spindle is run more than 30 minutes in a dry state, premature wear to the internal parts, abnormal noise, excess heat generation and internal oil leaks to the Brushless Motor Spindle will occur.
- ② Do not drop or hit this Brushless Motor Spindle, as shock can damage to the internal components.
- ③ Be sure to clean the collet and collet nut, the inside of the spindle before replacing the tool. If ground particles or metal chips stick to the inside of spindle or the collet, damage to the collet or spindle can occur due to the loss of precision.
- ④ When cleaning a Brushless Motor Spindle, stop the Brushless Motor Spindle and remove debris with a soft brush or a cloth. Do not blow air into the dust proof cover area (refer to section " 6 - 3 Outside View ") with compressed air as foreign particles or cutting debris may get into the ball bearing.
- ⑤ Always clean the tool shank before installing the tool in the spindle.
- ⑥ When sizing the correct collet size to the tool shank diameter, a tolerance of $+0 \sim - 0.01\text{mm}$ is strongly recommended.

A tool shank within the $+0 \sim - 0.1\text{mm}$ range is mountable, however, this may cause poor concentricity and or insufficient tool shank gripping force.
- ⑦ Select suitable products or tools for all applications. Do not exceed the capabilities of the Brushless Motor Spindle or tools.
- ⑧ Do not stop the supplied cooling air to the Brushless Motor Spindle during operation of the machine.

Removing the air pressure from the Brushless Motor Spindle causes a loss of purging, allowing the Brushless Motor Spindle to ingest coolant and debris. This will cause damage to the Brushless Motor Spindle.
- ⑨ When supplying coolant spray to the tool from outside of the Brushless Motor Spindle, while supplying coolant or oil mist to the Brushless Motor Spindle, carefully direct the coolant spray directly onto the tool. Do not direct the coolant spray directly on the Brushless Motor Spindle or the collet nut. Large amounts of coolant sprayed directly on the collet nut will cause excess load on the Brushless Motor Spindle, causing a loss of durability and longevity of the Brushless Motor Spindle.







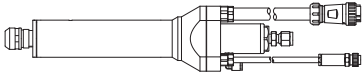

⚠ CAUTION

- ⑩ Stop working immediately when abnormal rotation or unusual vibration are observed. Immediately, please check the content of section " 15. TROUBLESHOOTING ".
- ⑪ Always check the tool, collet, collet nut, drain hose, coolant hose or oil mist hose and cooling air supply hose for damage before and after operating.
- ⑫ If the collet or collet nut show signs of wear or damage, replace them before a malfunction or additional damage occurs.
- ⑬ After installation, repair, initial operation, or long periods of non operation, please refer to section " 13 BREAK-IN PROCEDURE " detailed in Table. 3. When checking the Brushless Motor Spindle, no vibration or unusual sound should be observed during rotation.
- ⑭ Do not disassemble, modify or attempt to repair this Brushless Motor Spindle. Additional damage will occur to the internal components. Service must be performed by NSK NAKANISHI or an authorized service center.
- ⑮ When using this Brushless Motor Spindle for mass production, please consider the purchase of an additional Brushless Motor Spindle to be used as a back-up in case of emergency.
- ⑯ Securely connect each of the hoses (Coolant source connection, air hose, drain hose, coolant hose, or oil mist hose) to avoid accidental disconnection during use.

2. BASIC PACKAGE

When opening the package, check if it includes all items listed in " Table. 1 Packing List Contents ". In the event of any shortage, please contact either NAKANISHI (see the " 4. CONTACT US " section) or your local dealer.

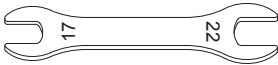
Table. 1 Packing List Contents

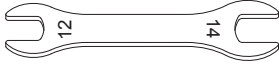
Common		
Brushless Motor Spindle • • 1pc. 	Insert • • 1pc. 	Ferrule Set • • 1set * 
Inspection Card • • 1pc. 	Operation Manual • • 1set 	
BMS - 4020 - MQL / BMS - 4040 - MQL		
Collet Nut (CHN - 16) • • 1pc.* 	Wrench (17 x 22) • • 2pcs. 	
BMS-4020-MQL-CHK / BMS-4040-MQL-CHK		
Collet Nut (K-265) • • 1pc.* 	Wrench (12 x 14) • • 2pcs. 	

* The Collet Nut and Ferrule Set are to be attached to the Brushless Motor Spindle.

3. WARRANTY

We provide a limited warranty for our products. We will repair or replace the products if the cause of failure is due to the following manufactures defects. Please contact us or your local distributor for details.

- (1) Defect in manufacturing.
- (2) Any shortage of components in the package.
- (3) Where damaged components are found when initially opening the package.
(This shall not apply if the damage was caused by the negligence of a customer.)

4. CONTACT US

For your safety and convenience when purchasing our products, we welcome your questions. If you have any questions about operation, maintenance and repair of the product, please contact us.

Contact Us

● For U.S. Market

Company Name : **NSK America Corp**
Industrial Div.
Business Hours : 8:30am to 17:00pm (CST)
(closed Saturday, Sunday and Public Holidays)
U.S. Toll Free No. : 800-585-4675
Telephone No. : 847-843-7664
Fax No. : 847-843-7622
Web Address : www.nskamericacorp.com

● For Other Markets

Company Name : **NAKANISHI INC.** 
Business Hours : 8:00am to 17:00pm
(closed Saturday, Sunday and Public Holidays)
Telephone No. : +81 (0) 289-64-3520
e-mail Address : webmaster-ie@nsk-nakanishi.co.jp

5. FEATURES

- (1) The Brushless Motor Spindle housing is made from precision ground, hardened, stainless steel (SUS) with an outside diameter of $\phi 40$ mm.
- (2) Excellent durability and high reliability are obtained by using a high-speed Brushless Motor, which eliminates the need for brush replacement and frequent maintenance.
- (3) Quick disconnect cords are utilized and available for easy Brushless Motor Spindle removal.

6. SPECIFICATIONS AND DIMENSIONS

6 - 1 Specifications

< Specification of the Brushless Motor Spindle >

Model	BMS - 4020 - MQL / BMS - 4020 - MQL-CHK	BMS-4020-MQL-2M / BMS-4020-MQL-CHK-2M	BMS - 4040 - MQL / BMS - 4040 - MQL-CHK	BMS-4040-MQL-2M / BMS-4040-MQL-CHK-2M
Maximum Motor Rotation Speed	20,000min ⁻¹ (rpm)		40,000min ⁻¹ (rpm)	
Spindle Accuracy	Less than 1μm			
Max. Output	1,200W			
Quick Disconnect Cord Length	0.3m	2m	0.3m	2m
Weight	2.3kg	2.8kg	2.3kg	2.8kg
Noise Level at 1m distance	Less than 70dB (A)			
IP Code	Motor Spindle : IP57 (While cooling air is supplied), Motor Cord : IPX7			

< Specifications for the Coolant and Oil Mist >

Coolant Type Supply	Coolant	Oil Mist
Pressure	0.2 - 3.0MPa (29 - 435.1 psi)	0.2 - 1.0MPa (29 - 145 psi)
Filtration Rating	Less than 5μm	
Supply Hose and Drain Hose Dimensions	Supply Hose : OD. φ6.0mm Drain Hose : OD. φ6.0mm x ID. φ4.0mm	Supply Hose : OD. φ6.0mm x ID. φ4.0mm Drain Hose : OD. φ6.0mm x ID. φ4.0mm

	Temperature	Humidity	Atmospheric Pressure
Operation Environment	0 - 40°C	MAX.75% (No condensation)	800 - 1,060hPa
Transportation and Storage Environment	-10 - 50°C	10 - 85%	500 - 1,060hPa

< Option >

BMS-4020-MQL / BMS-4040-MQL	
Collet (CH16OH- □□) *Note1	Collet Nut
φ3.0mm, φ3.175mm, φ4.0mm, φ5.0mm, φ6.0mm, φ6.35mm, φ7.0mm, φ8.0mm, φ9.0mm, φ10.0mm	CHN - 16
BMS-4020-MQL-CHK / BMS-4040-MQL-CHK	
Collet (CHK-OH- □□) *Note1	Collet Nut
φ3.0mm, 3.175mm, φ4.0mm, φ5.0mm, φ6mm, φ6.35mm	K-265

* Note 1 : Collet is sold separately. Please select the suitable collet size for your application.

Adjuster Bolt * Note 2	ADJUSTER BOLT
---------------------------	---------------

* Note 2 : The Adjuster Bolt is an option item specialized for BMS-4020/4040 MQL-CHK series only.

Motor Cord * Note 3	EMCD-4000- □ M (Power Line)	Length : 2m, 4m, 6m, 8m (The Air Hose (φ6mm) of the same length is attached.)
	EMCD-4000S- □ M (Signal Line)	Length : 2m, 4m, 6m, 8m (The Air Hose (φ6mm) of the same length is attached.)



* Note 3 : Motor Cord is sold separately.

Please select the suitable motor cord length for your application.

⚠ CAUTION

- 8 Meter Motor Cords (EMCD-4000-8M / EMCD-4000S-8M) cannot be used with the Brushless Motor Spindle (BMS-4020-MQL-2M / BMS-4020-MQL-CHK-2M / BMS-4040-MQL-2M / BMS-4040-MQL-CHK-2M). The Maximum Cord Length is 8 Meters.
- The insert and ferrule set are single use only. Once removed, a new insert and ferrule set are required.
 Replace the insert and ferrule set with new ones when removing the coolant hose or oil mist hose from the Brushless Motor Spindle. The insert and ferrule set are replacable by the end-user (Refer to Table. 2).

Table. 2

	Name	Model	Manufacturer
①	Insert 	SS-6M5-4M	SWAGELOK
②	Ferrule Set 	SS-6M0-SET	

6 - 2 Compatibility

The CONTROLLER is compatible with the following overseas safety standard.

- Safety standard in North America (UL,CSA) 
 UL1004 (+CSA 100-04)

6 - 3 Outside View

① BMS-4020-MQL / BMS-4020-MQL-2M / BMS-4040-MQL / BMS-4040-MQL-2M

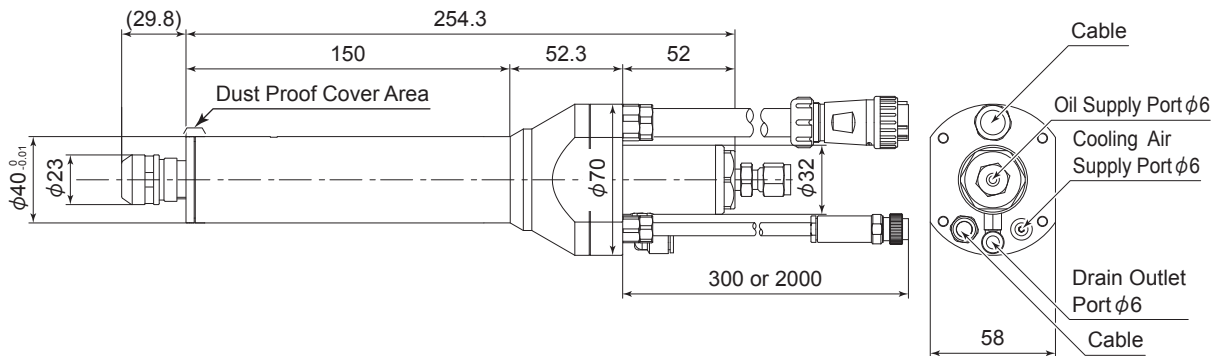

Fig. 1

② BMS-4020-MQL-CHK / BMS-4020-MQL-CHK-2M / BMS-4040-MQL-CHK / BMS-4040-MQL-CHK-2M

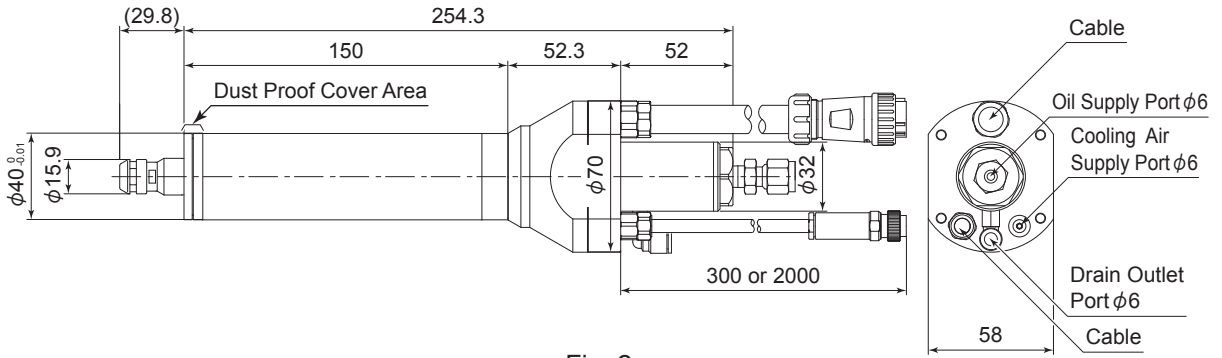

Fig. 2

6 - 4 Torque Characteristics

(1) BMS-4020-MQL series

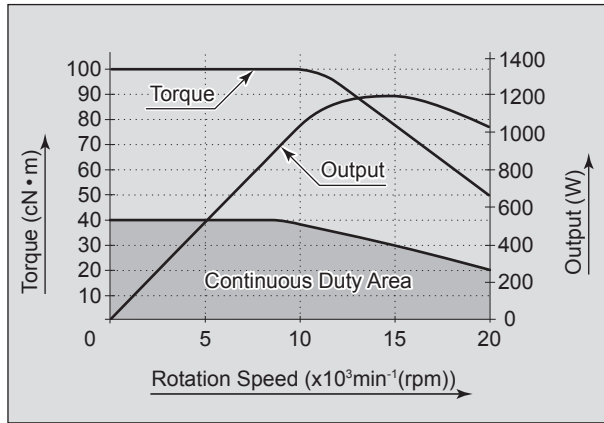

Fig. 3

(2) BMS-4040-MQL series

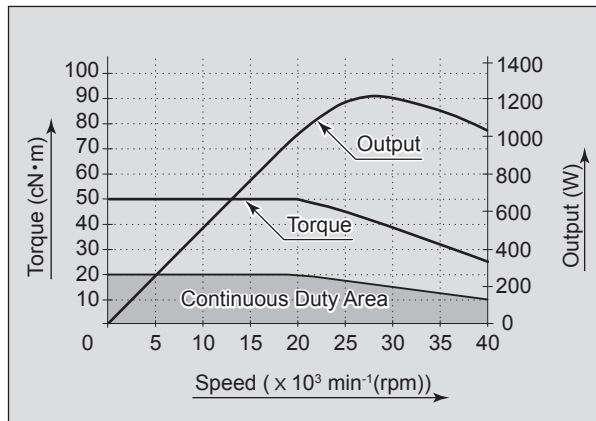

Fig. 4

6 - 5 Air Supply

Supply clean, dry, regulated air for Brushless Motor Spindle cooling. Regulate air pressure to between 0.2 - 0.35MPa (29 - 50.7psi). When using the Brushless Motor Spindle for continuous use, supply regulated air to CONTROLLER and set the air pressure to 0.35MPa (50.7psi).

7. CHANGING THE TOOL

⚠ CAUTION

- Do not tighten the collet without inserting the test bur or the tool shank into the collet, as this will damage the collet, spindle or collet nut, causing difficulty removing the collet.
- If the " Tool Mounting Depth " of the tool is less than 28mm, oil leaks from collet may occur. Always be sure to insert the tool into the collet so the tool extends into the collet at least 20mm (Collet CHK-OH type) / at least 28mm (Collet CH16OH type) from the face of the collet.

RECOMMENDATION

Please set the cutting tools to minimize the overhang amount. 13mm is the maximum amount of overhang to maintain high accuracy and safety.

- (1) Set the provided wrench (CHK-OH type : 12mm, CH16OH type : 17mm) on the spindle shaft.
- (2) Place the provided wrench (CHK-OH type : 14mm, CH16OH type : 22mm) on the collet nut and turn it counterclockwise to loosen the collet and remove the tool (The first turn will loosen the collet nut, but the tool will not release and turning will become stiff. Keep turning through the stiffness and the collet will open).
- (3) Clean the collet and collet nut before inserting the tool. " Tool Mounting Depth " of the tool is 20mm or more (Collet CHK-OH type) / 28mm or more (Collet CH16OH type) into the collet from face of the collet.
- (4) The new tool and tighten the collet by turning clockwise. Do not over-tighten.

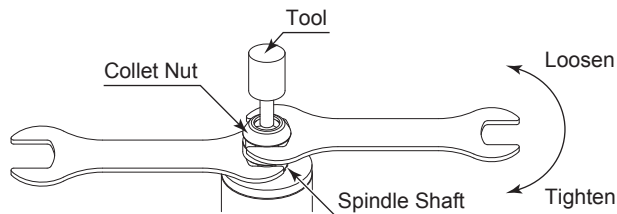

Fig. 5

8. REPLACING THE COLLET

⚠ CAUTION

When installing the collet into the collet nut, be sure to fully engage the latch inside the collet nut to the groove on the collets outer diameter area. In addition, remember that if the collet is attached without being engaged with the latch of the collet nut, the collet cannot be removed and this may cause damage to the collet or the spindle.

- (1) Remove the tool according to the section " 7. CHANGING THE TOOL " procedure above and remove collet nut assembly (Fig. 6).
- (2) The collet and collet nut are secured by a groove in the collet and a flange in the collet nut. To remove the collet hold the collet nut in one hand and push diagonally down on the collet. The collet should be released (Fig. 7).
- (3) To install the collet, hold the collet at a slight angle, and insert it into the collet nut (Fig. 8). Press the collet in the collet nut by positioning the collet in the collet nut and pressing down on flat surface (Fig. 9). Be sure to fully engage the latch inside the collet nut into the groove on the collet's outer circumference area (Fig. 9).

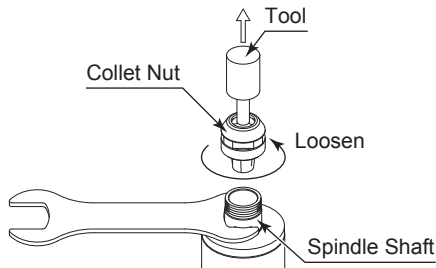

Fig. 6

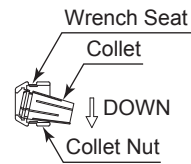

Fig. 7

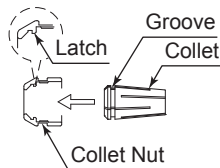

Fig. 8

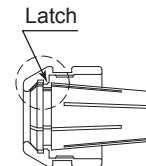

Fig. 9

9. CONNECTION OF MOTOR CORD

⚠ CAUTION

- Before connecting the Motor Cord to the Brushless Motor Spindle and CONTROLLER, verify the Main Power Switch on the CONTROLLER is turned OFF. If the Main Power Switch on the CONTROLLER is ON while connecting the Motor Cord, damage to the CONTROLLER is possible.
- Install the Protective Cap etc. to prevent damage or contamination to the Motor Cord Connector when not in use.

- (1) Remove the Protective Cap of the Motor Cord Connector (Motor Power Line and Motor Signal Line) and keep it for use when not using the Brushless Motor Spindle to keep the connector pins safe and clean.

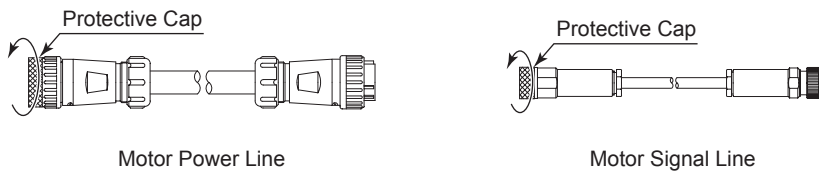

Fig. 10

- (2) Carefully insert the Alignment Pin of the Motor Cord into the Alignment Hole of the Motor / Spindle, then push straight the Alignment Pin into the Alignment Hole.

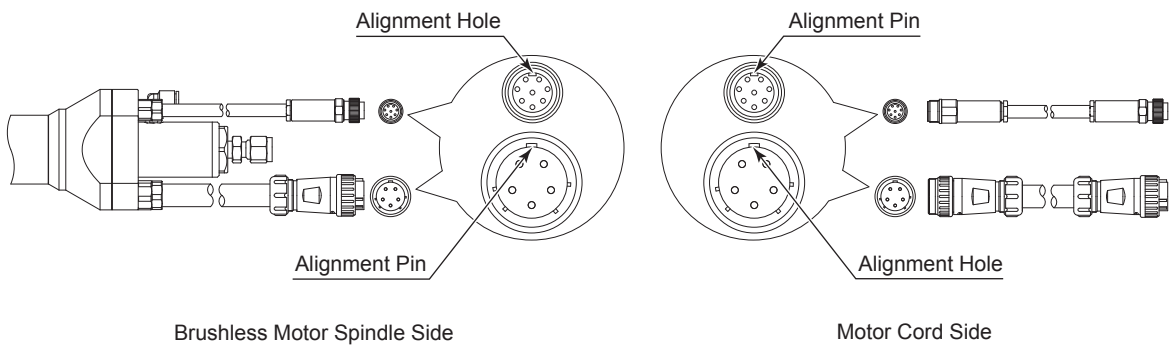

Fig. 11

- (3) Tighten the Connector Nut with clockwise.

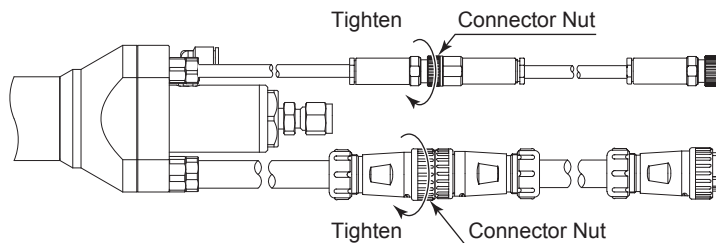

Fig. 12

(4) Insert the Air Hose of the Motor Cord side into the Dry Air Cooling Supply Port ($\phi 6$) on the rear of the Brushless Motor Spindle.

* The coolant Air Hose is attached to the Brushless Motor Spindle.

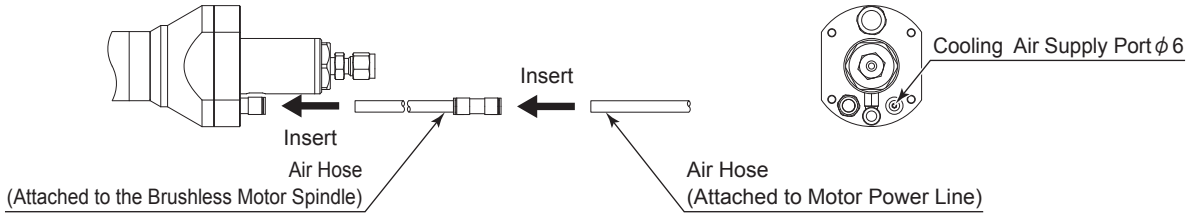

Fig. 13

(5) Insert the Drain Hose (Air Hose ($\phi 6$)) into the Drain Outlet Port on the rear of the Brushless Motor Spindle.

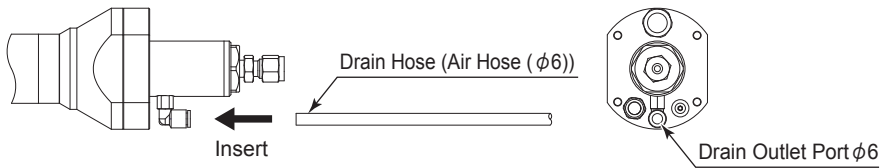

Fig. 14

10. CONNECTION OF THE COOLANT HOSE OR THE OIL MIST HOSE

⚠ CAUTION

The Insert and Ferrule Set are single use only.

Replace the Insert and Ferrule Set with new ones after removing the Coolant Hose or Oil Mist Hose from the Brushless Motor Spindle. The Insert and Ferrule Set are replacable by the end-user (Refer to P26 Table. 2).

10 - 1 Connection of the Oil Mist Hose (air pressure hose)

(1) Press the insert (Accessories) into the Oil Mist Hose ($\phi 6$: not included / prepared by the end-user) (Fig. 15).

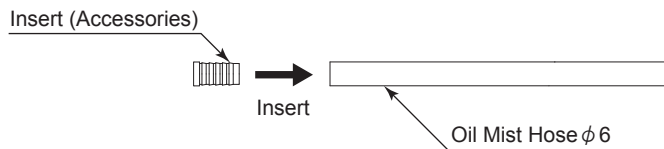

Fig. 15

(2) Insert the Oil Mist Hose of (1) into the Oil Supply Port ($\phi 6$) on the rear of the Brushless Motor Spindle (Fig.16).

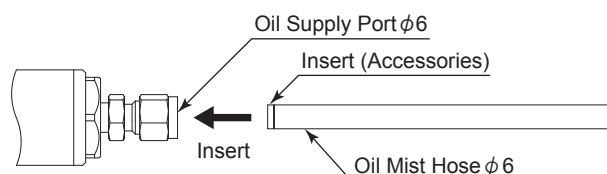

Fig. 16

- (3) Secure an adjustable wrench or 14mm open-end wrench (Wrenches not included) to the base (hexagon part) of the Joint, then tighten the Joint Nut securely by using an adjustable wrench or 14mm open-end wrench (Fig .17).

* The Coolant Supply Hose will be secured after the Ferrule Set is tightened.

- (4) Check that the Oil Mist Hose $\phi 6$ cannot be removed from the Oil Supply Port by lightly pulling the Oil Mist Hose $\phi 6$.

* If the Oil Mist Hose $\phi 6$ comes off from the Oil Supply Port, secure the hose by performing procedure (2) - (3) again.

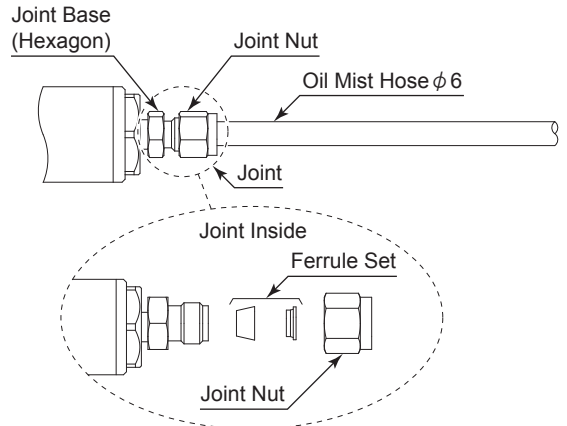

Fig. 17

10 - 2 Connection of the Coolant Hose

- (1) Insert the Coolant Hose into the Oil Supply Port $\phi 6$ on the rear of the Brushless Motor Spindle (Fig.18).

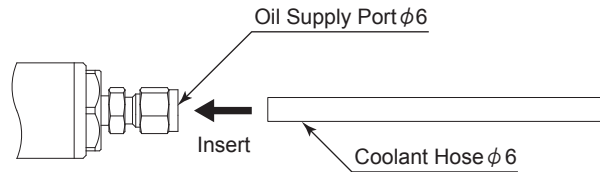

Fig. 18

- (2) Secure an adjustable wrench or 14mm open-end wrench (Wrenches not included) to the base (hexagon part) of the Joint, then tighten the Joint Nut securely by using an adjustable wrench or 14mm open-end wrench (Fig .19).

* The Coolant Supply Hose will be secured after the Ferrule Set is tightened.

- (3) Check that the Coolant Hose $\phi 6$ will not come off from the Coolant Supply Port, by lightly pulling the Coolant Hose $\phi 6$.

* If the Coolant Hose $\phi 6$ comes off from the Oil Supply Port, secure the hose by performing procedure (1) - (2) again.

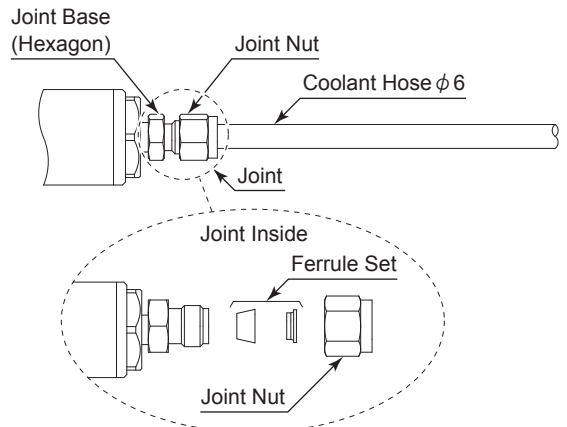

Fig. 19

11. THE METHODS OF SUPPLYING THE COOLANT OR OIL MIST

⚠ CAUTION

- A coolant or oil mist supply is required when operating this Brushless Motor Spindle.
 - * Never operate this Brushless Motor Spindle in a dry condition when using water based coolant. It will cause internal damage to the Brushless Motor Spindle.
- If this Brushless Motor Spindle is being used in a dry cutting condition, always initially supply either oil based coolant or oil mist to the unit. After every 30 minutes of dry operation, oil based coolant or oil mist must be re-introduced to the unit. Never operate this unit for no more than 30 minutes in a dry state. If this Brushless Motor Spindle is run more than 30 minutes in a dry state, premature wear to the internal parts, abnormal noise, excess heat generation and internal oil leaks to the Brushless Motor Spindle will occur.
- Always supply the coolant air first into the Brushless Motor Spindle, then you may supply the coolant or oil mist into the Brushless Motor Spindle.

If the oil mist or coolant is supplied into the Brushless Motor Spindle before the coolant air is supplied to Brushless Motor Spindle, leakage from the coolant or oil mist will seep inside the Brushless Motor Spindle, resulting in damage to the Brushless Motor Spindle. It is imperative that cooling air be supplied first to assure purging of the Brushless Motor Spindle.
 - Coolant or Oil Mist must be filtered to a filtration accuracy of 5µm or less.
 - When using the Brushless Motor Spindle with the oil mist supplied for the first time, or after a long period of a non-use, supply the cooling air first, then supply the oil mist for a minimum of 5 minutes into the motor / spindle prior to use. If using the Brushless Motor Spindle is operated without supplying sufficient oil mist, wear to the internal parts, abnormal noise, abnormal heat generation and oil leakage into the Brushless Motor Spindle will result.

11 - 1 Operation

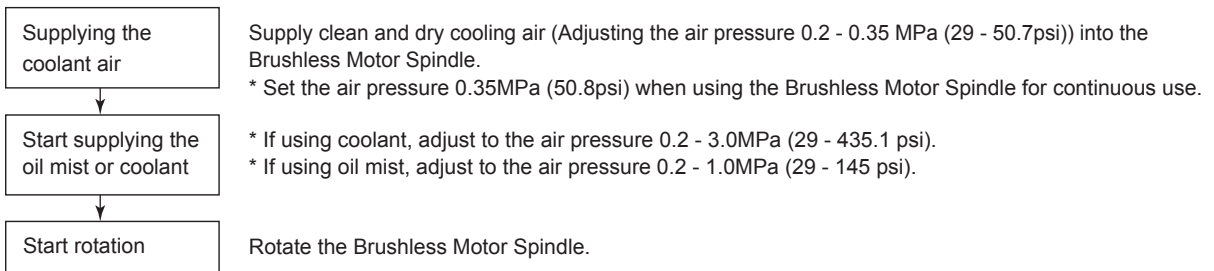

Fig. 20

⚠ Cautions for Discharging Drainage

- Never extremely bend or break the Drain Hose $\phi 6\text{mm}$, causing a restriction to the drainage discharge. If the drainage cannot be easily discharged, seeping of the drainage into the inside of the Brushless Motor Spindle will occur, causing extreme damage to internal components, which will result in a malfunction.
- After stopping the supply of the coolant or oil mist, be sure to allow at least 5 minutes of cooling air into the unit to allow adequate time to purge the Brushless Motor Spindle. If the drainage is allowed to remain inside the unit, damage will result causing a malfunction to the Brushless Motor Spindle.

11 - 2 Stopping Operation

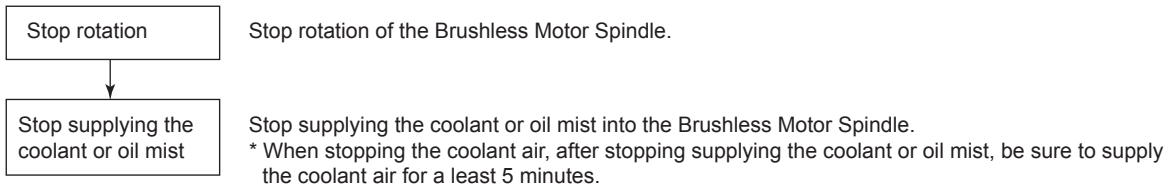

Fig. 21

12. INSTALLATION OF THE BRUSHLESS MOTOR SPINDLE

⚠ WARNING

When installing a Brushless Motor Spindle to a fixed base, make sure the fixed base is grounded in order to avoid the risk of an electric shock.

⚠ CAUTION

- When installing a Brushless Motor Spindle, do not hit, drop or cause shock to the Brushless Motor Spindle. This may cause damage to internal components and result in malfunctions.
- When mounting the Brushless Motor Spindle, be sure to secure within Clamping Area etched on the Brushless Motor Spindle O.D. If the Brushless Motor Spindle is installed incorrectly, damage to the internal components is possible.
- Cautions when tightening the securing bolts on to a Split Type Holder
Do not over-tighten the bolt. This will cause damage to Brushless Motor Spindle's precision. Tighten the bolt until the Brushless Motor Spindle body can not be rotated by hand within the fixture.
Extreme tightening is not necessary or recommended.
Apply working force and check that the Brushless Motor Spindle is tight before using.

(1) When mounting a Brushless Motor Spindle, refer to the Clamping Area etched on the Brushless Motor Spindle (Fig. 22).

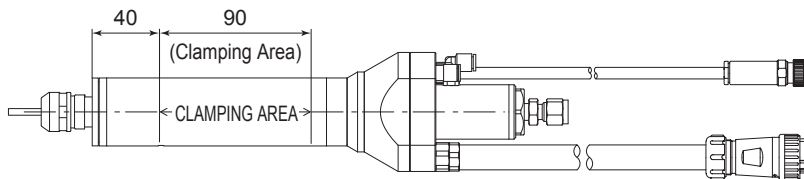

Fig. 22

* When installing the Brushless Motor Spindle, it is recommended to use a " Grip Ring GR - 40 (sold separately (Fig. 23)) ". If the Grip Ring GR - 40 cannot be used due to the restriction of dimension and space, install as shown in (2) below.

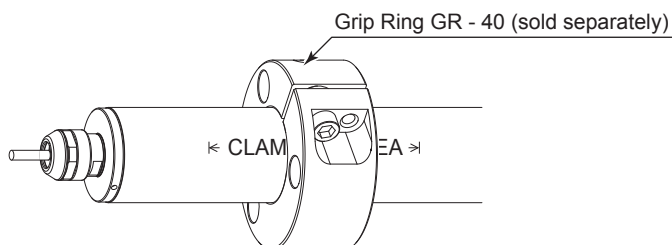

Fig. 23

(2) When installing a Brushless Motor Spindle to the holder, recommended installation method is shown Fig. 24. Refer to " (3) How to fabricate the Split Type Holder ".If this is not possible, install as shown in Fig. 25.

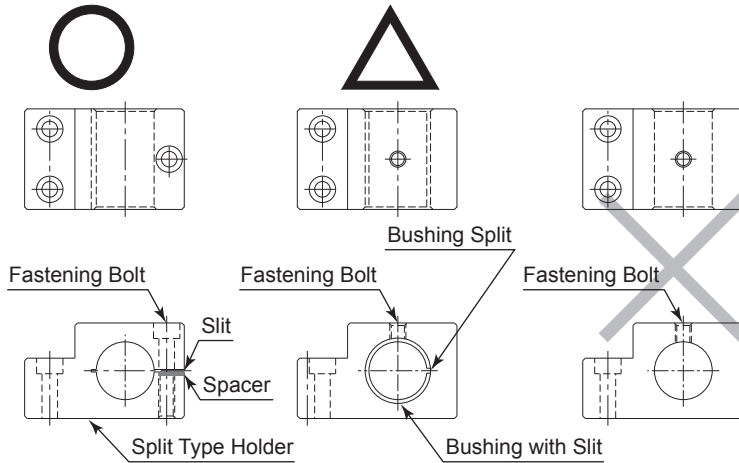

Fig. 24

Fig. 25

Fig. 26

CAUTION

Do not allow set screws to come directly in contact with the Brushless Motor Spindle body as shown in Fig. 26, as this will result in damage to the Brushless Motor Spindle housing and internal components. When installing, never clamp directly over the bearings, as this will result in bearing damage (Refer to Fig. 27).

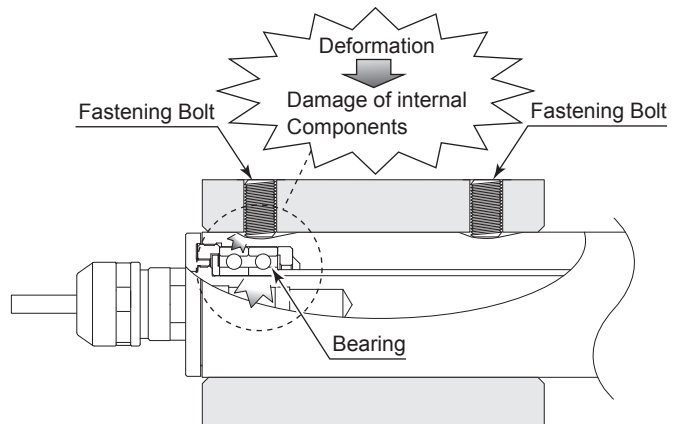

Fig. 27

(3) How to fabricate the Split Type Holder

- ① Rough bore the inside diameter of the Split Type Holder.
- ② Cut a slit. (Ex. Slit 2mm) wide.
- ③ Tighten the Screw for Removal and Force Open the Slit Area.
- ④ Insert a spacer (Ex. thickness = 2mm) into the Slit Area.
- ⑤ Loosen the Screw for Removal, and tighten the fastening bolt with its specified (recommended) torque.
- ⑥ Finish the Split Type Holder so that the inside diameter of the Split Type Holder is $\phi 40$ with its tolerance range from -0.01mm to -0.015mm , and its roundness and cylindricity of less than $5\mu\text{m}$.
- ⑦ When inserting the Brushless Motor Spindle loosen the Fastening Bolt, and tighten the Screw for Removal, widening the Slit Area.

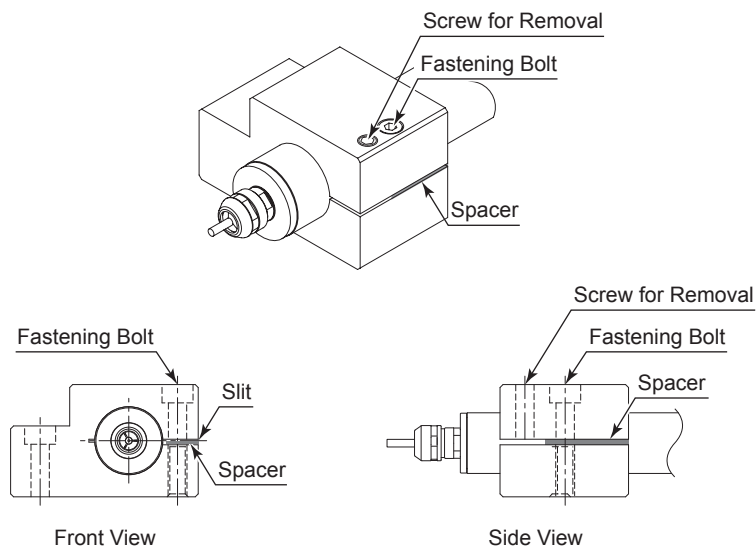

Fig. 28

⚠ CAUTION

- How to confirm the correct tightening or clamping of the Brushless Motor Spindles in the holder. Fasten the holder so that the increase in the no-load current value (during rotation at the maximum rotation speed) with the Brushless Motor Spindle fastened is 50mA (for type 200V / 230V) or less, compared to the no-load current value (during rotation at the maximum rotation speed) without fastening the Brushless Motor Spindle. Do not over-tighten the Fastening Bolt. It may damage Brushless Motor Spindle's precision and shorten the life of the bearings.
- The final responsibility for ensuring holder's safety for use in a given application is left to the designer of the equipment in which NAKANISHI's Brushless Motor Spindle is installed. NAKANISHI offers Brushless Motor Spindle with a wide variety of capabilities and specifications. Please carefully check the Brushless Motor Spindle's specifications against the requirements of your equipment and verify suitability and safety of the Holder prior to initial use.

13. BREAK-IN PROCEDURE

CAUTION

Always apply cooling air 0.2 - 0.35 MPa (29 - 50.7 psi) first, and then supply the coolant or oil mist before initiating the " BREAK-IN PROCEDURE ".

If using the Brushless Motor Spindle without supplying sufficient cooling air pressure, coolant or oil mist, will cause wear to the internal components, abnormal noise, abnormal heat generation and oil leaks in the Brushless Motor Spindle.

During transportation, storage or installation, the grease inside the bearings will settle. If the Brushless Motor Spindle is suddenly run at high-speed, the grease will be ejected from the bearings, causing excessive heat that will cause bearing damage.

After installation, repair, initial operation, or long periods of non operation, please follow the break-in procedure detailed in Table. 3.

Table. 3

Steps	1	2	3	4
BMS-4040-MQL series Rotation Speed (min^{-1}) (rpm)	10,000	20,000	30,000	40,000
BMS-4020-MQL series Rotation Speed (min^{-1}) (rpm)	5,000	10,000	15,000	20,000
Rotation Time (min)	15	10	10	15
Items to Check	No Abnormal Noises.	The Brushless Motor Spindle housing temperature during the break-in process should not exceed 25 degrees C (36 degrees F) above ambient temperature. Should the Brushless Motor Spindle exceed this limit, rest the Brushless Motor Spindle for at least 20 minutes and re-start the break in procedure from the beginning. If the housing temperature rises again and exceeds 25 degrees C (36 degrees F) above ambient temperature, check the Brushless Motor Spindle for proper installation.		The Brushless Motor Spindle housing temperature during the break-in process should not exceed 25 degrees C (36 degrees F) above ambient temperature.

14. CAUTIONS WHEN USING GRINDSTONES AND TOOLS

⚠ CAUTION

The maximum surface speed or rpm is always specified for a grindstone. Do not exceed the maximum speed with reference to the calculating chart below. Always follow the grindstone manufacturer's recommendations.

$$\text{Surface Speed (m / s)} = \frac{3.14 \times \text{Diameter (mm)} \times \text{Rotation Speed (min}^{-1}) \text{ (rpm)}}{1,000 \times 60}$$

- (1) The proper surface speed for general grindstones is 10 - 30m / s.
- (2) Do not exceed 13mm of overhang for mounted grindstones as shown in Fig. 28. If the overhang must exceed 13mm, reduce the Brushless Motor Spindle speed in accordance with Table. 4.
- (3) Dress the grindstone prior to use.
- (4) Do not use cutting tools with bent or broken shanks, cracks or excessive run-out.
- (5) For grinding, the maximum depth of cut should not exceed 0.01mm radially or axially. Reciprocate the tool several times after each pass to eliminate tool pressure.
- (6) Always operate cutting tools within the allowable recommended speed of the cutting tools. Use of a cutting tool outside of the allowable speed of the cutting tools could cause damage to the spindle and injury to the operator.
- (7) Keep the cutting tool shank and collet clean. If contaminants are left in the collet or collet nut, excessive run-out will cause damage to the cutting tool and or spindle.
- (8) Do not strike or disassemble the Brushless Motor Spindle.
- (9) Please set the cutting tools to minimize the overhang amount. 13mm is the maximum amount of overhang to maintain high accuracy and safety.

Table. 4 Overhang and Speed

Overhang (mm)	Max. Speed (min ⁻¹) (rpm)
20	N x 0.5
25	N x 0.3
50	N x 0.1

* N = Max. Operating Speed with 13mm overhang.

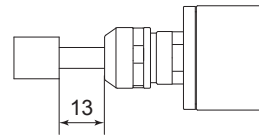

Fig. 29

15. HOW TO USE ADJUSTER BOLT DEPTH STOP

The Adjuster Bolt Depth Stop is an option designed exclusively for the BMS-4020 / 4040-MQL-CHK Series only. Tool depths can be adjusted or preset by adjusting the position of the Adjuster Bolt Stop.

- Tool Stop Position: 39mm - 51mm from the face of the Collet Nut (Fig. 30).
- Adjuster Bolt slot dimensions: Slot Width 1.5mm / Slot Depth 1.5mm (Fig. 31).
- Use a flat blade screw driver with a width of 4.5mm and a length of 50mm to properly fit the Adjuster Bolt in the face of the Tool Depth Stop (Fig. 32).
- Rotate the Adjuster Bolt Clockwise or Counterclockwise to properly set the desired depth for the Tool Depth Stop position.

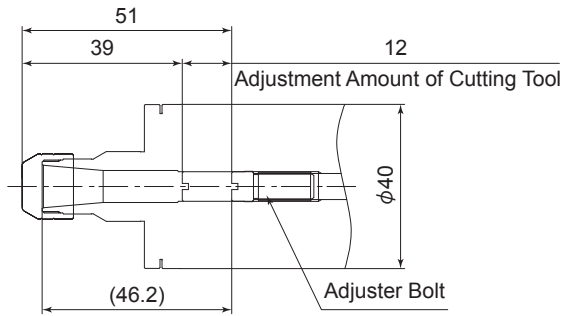

Fig. 30

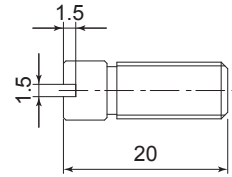

Fig. 31

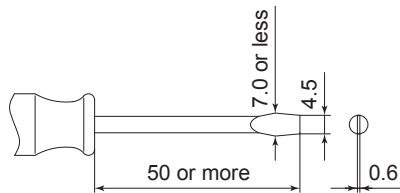

Fig. 32

16. TROUBLESHOOTING

If a problem or concern occur, please check the following items prior to consulting your dealer.

Trouble	Cause	Inspection / Corrective Action
Brushless Motor Spindle does not rotate or rotate smoothly.	The spindle ball bearings have been damaged.	Replace the ball bearings. (Return to NAKANISHI dealer service.)
	The motor has been damaged.	Replace the motor. (Return to NAKANISHI dealer service.)
Overheating during rotation.	Cutting debris has contaminated the ball bearings, and the ball bearings are damaged.	Replace the ball bearings. (Return to NAKANISHI dealer service.)
	Low air pressure.	Check air hose connection and air pressure.
Abnormal vibration or noise during rotation.	The tool shank is bent.	Replace the tool.
	Cutting debris has contaminated the ball bearing.	Replace the ball bearings. (Return to NAKANISHI dealer service.)
	The spindle ball bearings have been damaged.	
Tool slippage.	Collet or collet nut is not correctly installed.	Check and clean the collet and collet nut. Reinstall the collet and collet nut.
	The collet and the collet nut are worn.	Replace the collet and collet nut.
High run-out.	The tool is bent.	Change the tool.
	Collet nut is not correctly installed.	Secure the collet and the collet nut correctly.
	The collet and the collet nut are worn.	Replace the collet and the collet nut.
	Inside of the spindle is worn.	Replace the spindle shaft. (Return to NAKANISHI dealer service.)
	Contaminants inside the collet and the collet nut or the spindle.	Clean the collet, collet nut and the inside of the taper and spindle.
	The spindle ball bearings have been damaged.	Replace the ball bearings. (Return to NAKANISHI dealer service.)
Coolant or oil mist does not flow from the tip of tool.	Tool is damage or tool is clogged.	Replace the cutting tool.
	Low pressure of the coolant or oil mist.	Check and adjust the pressure of the coolant or oil mist.
	The motor has been damaged.	Replace the motor. (Return to NAKANISHI dealer service.)
A large amount of oil mist or coolant is leaking from the Drain Outlet Port.	The motor has been damaged.	Replace the motor. (Return to NAKANISHI dealer service.)
The oil leaking from the collet.	" Tool Mounting Depth " is less than 28mm from the collet face.	Be sure to insert the tool, " Tool Mounting Depth " to a depth of 20mm or more (Collet CHK-OH type) / 28mm or more (Collet CH16OH type) from the collet face.
	Inside of the spindle is worn.	Replace the spindle shaft. (Return to NAKANISHI dealer service.)
	Contaminants inside the collet and the collet nut or the spindle.	Clean the collet, collet nut and the inside of the taper and spindle.

Refer to the E4000 CONTROLLER Operation Manual.

17. DISPOSAL OF THE BRUSHLESS MOTOR SPINDLE

When disposal of a Brushless Motor Spindle is necessary, follow the instructions from your local government agency for proper disposal of industrial components.

株式会社 **ナカニシ** www.nakanishi-inc.com

本社・工場 〒322-8666 栃木県鹿沼市下日向 700
TEL : 0289(64)3380 FAX : 0289(62)5636

本書の内容は、改善のため予告無しに変更することがあります。

NAKANISHI INC.  www.nakanishi-inc.com

700 Shimohinata, Kanuma, Tochigi 322-8666, Japan

NSK America Corp www.nskamericacorp.com

1800 Global Parkway, Hoffman Estates, IL 60192, USA

Contents are subject to change without notice.