

クーラントスルースピンドル / Coolant Through Spindle

CTS - 3030

取扱説明書 / OPERATION MANUAL

日本語 : P1 - P19 / English : P21 - P41

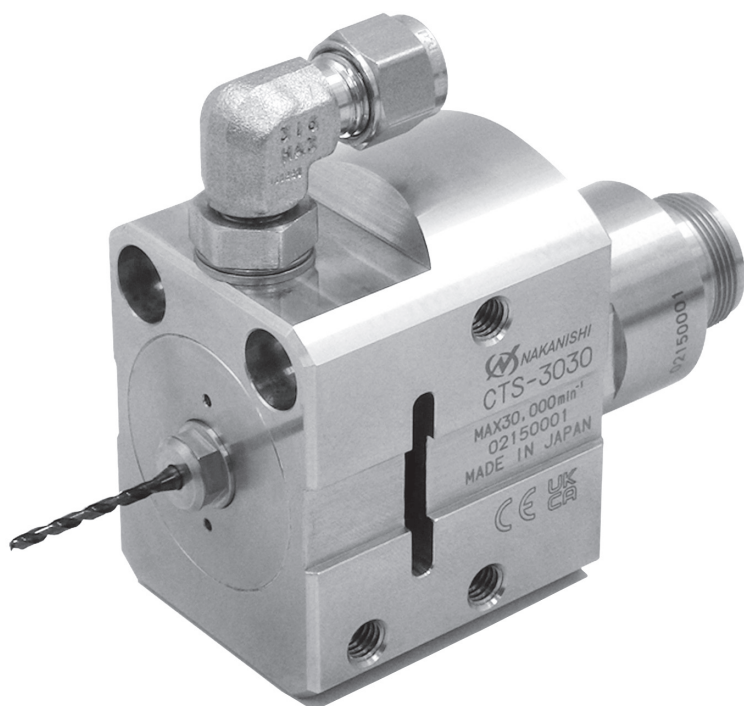

Thank you for purchasing Coolant Through Spindle CTS-3030. This spindle is designed for use with small-diameter cutting tools with a coolant hole. The E3000 <CONTROLLER>, EM-3030T <Motor> and <Air Line Kit> are required to drive this spindle. Read this and all the associated component Operation Manuals carefully before use. Always keep this Operation Manual for future reference in a place that is easily accessible to users.

Contents

1. CAUTIONS FOR HANDLING AND OPERATION	P21
2. BASIC PACKAGE	P24
3. WARRANTY	P25
4. CONTACT US	P25
5. FEATURES	P25
6. SPECIFICATIONS AND DIMENSIONS	P26
7. CONNECTION TO THE MOTOR	P28
8. CHANGING THE TOOL	P29
9. REPLACING THE COLLET	P30
10. INSTALLING THE HIGH-PRESSURE PUMP, COOLANT HOSE AND FITTINGS	P31
11. SUPPLYING THE COOLANT	P36
12. INSTALLING THE SPINDLE	P36
13. BREAK-IN PROCEDURE	P38
14. CAUTIONS WHEN USING CUTTING TOOLS	P39
15. TROUBLESHOOTING	P40
16. DISPOSAL OF THE SPINDLE	P41

1. CAUTIONS FOR HANDLING AND OPERATION

- Read these warnings and cautions carefully and only use in the manner intended.
- These warnings and cautions are intended to prevent potential hazards that could result in personal injury or damage to the device. They are classified as follows in accordance with the seriousness of the risk.

Class	Degree of Risk
⚠ WARNING	This indicates the presence of a hazard that could result in personal injury or damage to the device if the safety instructions are not followed properly.
⚠ CAUTION	This indicates a potential hazard that could result in minor or moderate personal injury or damage to the device if the safety instructions are not followed properly.

 **WARNING**

- (1) The spindle is not a hand tool. It is designed to be installed and used in machine tools or special purpose machines.
- (2) Do not touch the cutting tool while it is running. It is very dangerous.
- (3) Wear safety glasses and a dust mask, and use a protective cover around the spindle whenever the spindle is rotating.
- (4) Never connect, disconnect or touch the Power Cord Plug or Motor Cord Plug with wet hands. This may cause an electric shock.
- (5) Never operate or handle the spindle until you have thoroughly read the Operation Manual and safe operation has been confirmed.
 - 1) To prevent injury and damage, check the spindle and cutting tool for proper installation before operating the spindle.
 - 2) Before disconnecting the spindle, check the safety of the spindle and cutting tool, turn OFF the control power, stop the supply of coolant and compressed air, and release the residual coolant and compressed air from the system.
- (6) When installing the spindle, make sure that the fixed base is grounded to the machine tool in order to avoid the risk of an electric shock.
- (7) When installing a tool, tighten the collet properly and check the collet and collet nut again before use. Do not overtighten the collet. Doing so may cause damage to the spindle.
- (8) Do not use bent, broken, chipped, out-of-round or sub-standard tools, as this may cause them to shatter or explode. Tool with fractures or a bent shank may cause injury to the operator. When using a new tool, start rotating it at a low speed, and gradually increase the speed to check the safety.
- (9) Do not exceed the maximum recommended allowable tool speed. For your safety, use speeds below the maximum allowable speed.
- (10) Do not apply excessive force. This may cause tool slippage, tool damage, injury to the operator or loss of concentricity and precision.
- (11) When using coolant, check the operating pressure before connecting the coolant hose and fittings. If the maximum operating pressure of the coolant hose or fittings is exceeded, they could burst and cause injury.
- (12) Connect the coolant hose and fittings securely. A coolant leak could cause injury or damage the device.
- (13) When using an oil-based coolant, the coolant may be dispersed as a fine mist that could ignite. Implement fire prevention measures such as the use of dust collectors and automatic fire extinguishers.
- (14) If there is residual pressure in the high-pressure pump, the tool may pop out, resulting in injury. Make sure that there is no residual pressure before replacing the tool.

 **CAUTION**

- (1) A supply of coolant is required when using this spindle. If the spindle is used without supplying coolant, the generated heat could damage the components.
- (2) Use coolant with an ISO viscosity grade of VG 32 or lower.
- (3) Do not drop or hit the spindle, as shock can damage the internal components.



 **CAUTION**

- (4) Be sure to clean the collet, the collet nut and the inside of the spindle before replacing the tool. If ground particles or metal chips stick to the inside of the spindle or the collet, damage to the collet or spindle can occur due to the loss of precision.
- (5) When cleaning the spindle, stop the motor and remove debris with a soft brush or a cloth. Never blow compressed air into the wrench flats section (refer to section " 6 - 2 Outside view "), as foreign particles or cutting debris may get into the ball bearings and cause damage.
- (6) Always clean the tool shank before installing the tool in the spindle. Foreign matter in the collet or collet nut may cause excessive run-out that could damage the cutting tool or spindle.
- (7) Use a cutting tool with a shank diameter that is within a tolerance of $+0 \sim -0.01$ mm of the collet diameter.
- (8) Select suitable products or tools for all applications. Do not exceed the capabilities of the spindle or tools.
- (9) To prevent dust from entering while the machine is operating, do not stop the supply of cooling air from the motor. If the supply of cooling air is stopped while coolant and cutting oil is being supplied, the air purge will be lost and the coolant and cutting oil may enter the spindle and cause damage.
- (10) When using an external supply of cutting fluid in addition to the coolant, ensure that the cutting oil is sprayed directly on the cutting edge while machining is performed. Avoid spraying the spindle as much as possible.
- (11) If abnormal rotation or vibration occurs while operating the spindle, immediately stop working and perform inspection. (Refer to section " 15. TROUBLESHOOTING ".)
- (12) Check the cutting tool, collet, collet nut, coolant hose and fittings for damage and wear each day before and after work.
- (13) The collet and collet nut are consumable parts. If the collet or collet nut shows signs of wear or damage, replace it before a malfunction or additional damage occurs.
- (14) Before operating for the first time after installation, repair, or a long period of non-operation, refer to section " 13. BREAK-IN PROCEDURE ". When checking the spindle, no vibration or unusual sound should be observed during rotation.
- (15) Do not disassemble, modify or attempt to repair the spindle. Otherwise, the performance cannot be guaranteed and subsequent repair requests may be denied.
- (16) When using the spindle for mass production, please purchase another spindle as a spare in case of emergency.

2. BASIC PACKAGE

When opening the package, check if it includes all items listed in " Table. 1 Packing List Contents ".
In the event of any shortage, please contact either NAKANISHI (refer to section " 4. CONTACT US ")
or your local dealer.

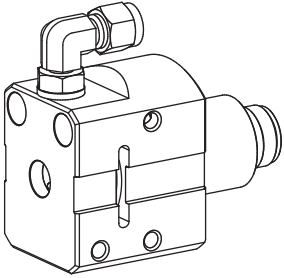
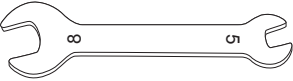
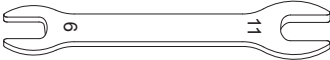
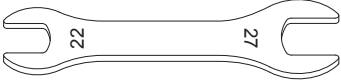
Table. 1 Packing List Contents

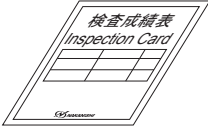
<p>Spindle ··· 1 pc</p> 	<p>Wrench (8 × 5) ··· 1 pc</p> 
<p>Wrench (9 × 11) ··· 1 pc</p> 	<p>Wrench (22 × 27) ··· 1 pc</p> 
<p>Operation Manual ··· 1 set</p> 	<p>Inspection Card ··· 1 pc</p> 

3. WARRANTY

We provide a limited warranty for our products. We will repair or replace the products if any of the cases (1) to (3) below occur.

Please contact us (refer to section " 4. CONTACT US ") or your local dealer for details.

- (1) Defect in manufacturing
- (2) Shortage of components in the package
- (3) Damaged components found when initially opening the package
(This shall not apply if the damage was caused by the negligence of the customer.)

4. CONTACT US

For your safety and convenience when purchasing our products, we welcome your questions.

If you have any questions about operation, maintenance and repair of the product, please contact us.

Contact Us

● For U.S. Market

Company Name	: NSK America Corp. Industrial Div.
Business Hours	: 8:00 to 17:00 (CST) (closed Saturday, Sunday and Public Holidays)
U.S. Toll Free No.	: +1 800 585 4675
Telephone No.	: +1 847 843 7664
Fax No.	: +1 847 843 7622
Website	: www.nskamericacorp.com

● For Other Markets

Company Name	: NAKANISHI INC. 
Business Hours	: 8:00 to 17:00 (JST) (closed Saturday, Sunday and Public Holidays)
Telephone No.	: +81 289 64 3520
e-mail	: webmaster-ie@nsk-nakanishi.co.jp

5. FEATURES

- (1) Coolant can be supplied and discharged from a cutting tool with a coolant hole, enabling deep hole drilling and high-efficiency machining.
- (2) The spindle supports a coolant pressure of up to 20 MPa.
- (3) With the coolant supply located in front and a compact profile, the spindle can be installed in automatic lathes produced by machine tool manufacturers.

6. SPECIFICATIONS AND DIMENSIONS

6 - 1 Specifications

Model	CTS-3030
Max RPM	30,000 min ⁻¹
Spindle Accuracy	Within 1 μm
Applicable Motors	EM-3030T-J / EM-3030T-J-2M, EM-3030T (Straight cord)
Weight	885 g
Noise Level (at 1 m Distance)	60 dB (A) or less

< Coolant specifications >

Supply Fluid	Coolant
Pressure	3.0 - 20.0 MPa
Filtration Accuracy	5 μm or less
Supply Hose/Fittings (Provided by Customer)	Pressure resistance of 20.0 MPa or more

	Temperature	Humidity	Atmospheric Pressure
Operation Environment	0 - 40°C	MAX. 75% (No condensation)	800 - 1,060 hPa
Transportation and Storage Environment	-10 - 50°C	10 - 85%	500 - 1,060 hPa

< Options >

Collet (CHA-□□) *Note 1	φ3.0 mm, φ3.175 mm, φ4.0 mm
Collet Nut (CHN-CTA-□□) *Note 1	φ3.0 mm, φ3.175 mm, φ4.0 mm

*Note 1: The collet and collet nut are sold separately. Please select the suitable collet size for your application.

6 - 2 Outside View

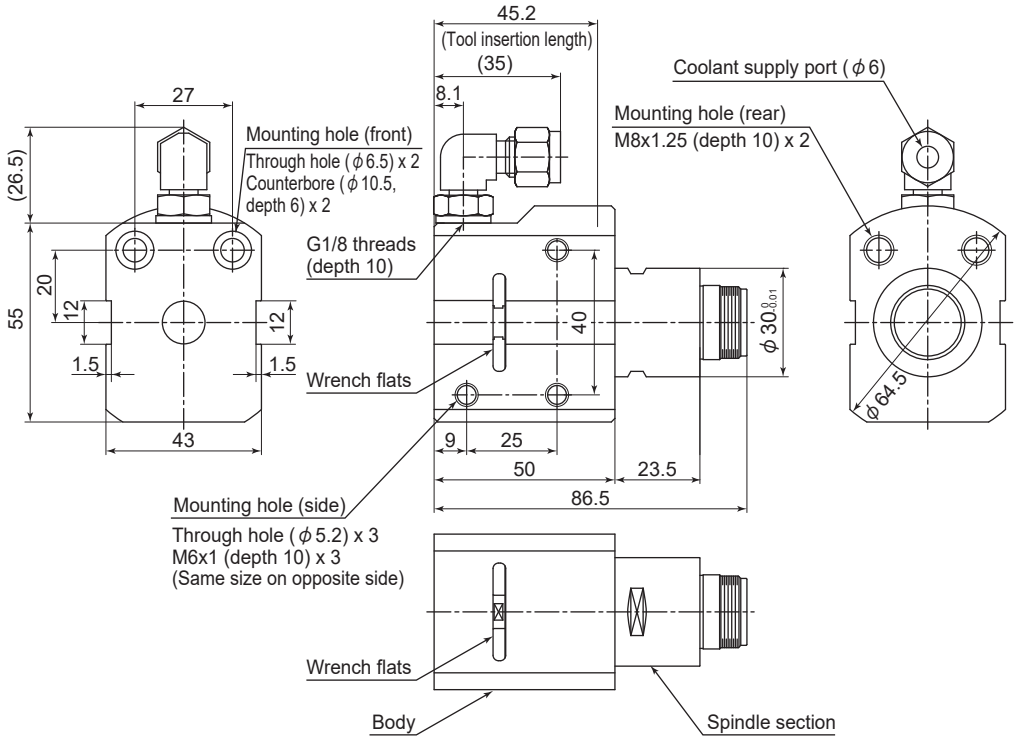

Fig. 1

7. CONNECTION TO THE MOTOR

⚠ CAUTION

- **Make sure that your hands and all interlocking parts of the spindle and machine are clean before connecting the spindle. This is critical to prevent foreign matter from entering the spindle.**
- **Mount the spindle on the motor as straight as possible to prevent the mating parts from seizing.**
- **Mount the spindle on the motor by using one wrench on the flats of the spindle and another wrench on the flats of the motor. Never attempt to tighten the motor by holding the body of the spindle or motor.**

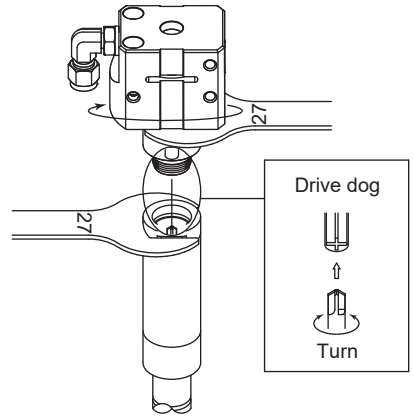

Fig. 2

Align the threads on the front end of the motor and the rear end of the spindle, and turn the spindle clockwise. If the drive shaft of the motor does not engage the drive dog on the spindle, do not attempt to forcibly tighten the spindle. Turn the spindle back a few threads, turn the drive shaft of the motor to engage it with the drive dog, and then tighten the spindle with the provided 27 mm wrench.

8. CHANGING THE TOOL

⚠ WARNING

If there is residual pressure in the high-pressure pump, the tool may pop out, resulting in injury. Make sure that there is no residual pressure before replacing the tool.

⚠ CAUTION

- Never tighten the collet nut without inserting a cutting tool in the collet. Excessively tightening the collet may damage the tabs that hold the collet in the collet nut, making it difficult to remove the collet from the spindle.
- Keep the overhang length to a minimum when installing the cutting tool. If the overhang length is too long, the cutting tool may bend and cause injury.

- (1) Place the provided 8 mm wrench on the wrench flats of the spindle shaft.
(There are three pairs of wrench flats. Position the wrench on the flats so that it is easy to hold.)
- (2) Place the provided 9 mm wrench on the collet nut and turn it counterclockwise to loosen the collet and remove the tool. (The first turn of the collet holder is stiff. Keep turning through the stiffness and the collet will open.)
- (3) Insert the new tool and turn the collet nut clockwise to secure the tool.

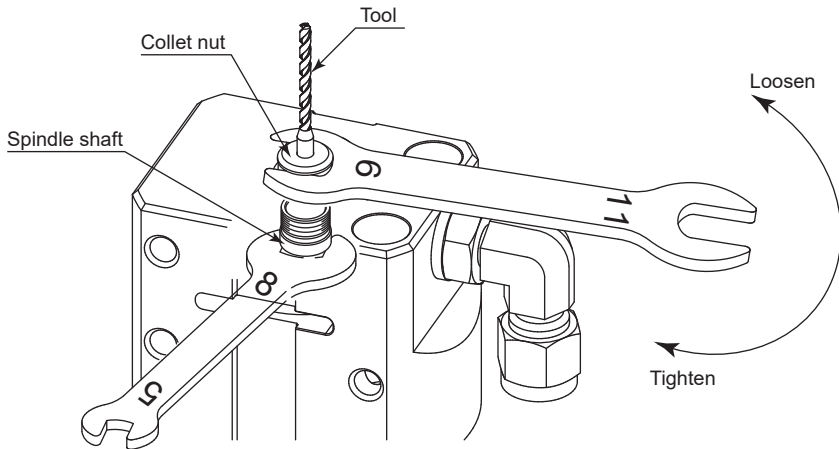

Fig. 3

9. REPLACING THE COLLET

⚠ CAUTION

When installing the collet in the collet nut, make sure that the tabs of the collet nut are properly seated in the groove of the collet. If the tabs are not properly seated when you tighten the collet nut, the collet may become stuck inside the spindle.

- (1) Loosen the collet nut with the cutting tool installed as described in section " 8. CHANGING THE TOOL ". Keep turning the collet nut until it comes out of the spindle shaft together with the cutting tool, and then remove the cutting tool from the collet. (Fig. 4)
- (2) Hold the collet nut in one hand, and tilt the collet to one side to release it. If the collet is not released, try tilting it to the other side. (Fig. 5)
- (3) Hold the collet nut in one hand, and install the collet. (Fig. 6)

If the collet is difficult to install, tilt the collet to one side when inserting it, so that the tabs can more easily be seated in the groove. (Fig. 5, Fig. 6)

At this time, make sure that the tabs of the collet nut are properly seated in the groove of the collet. (Fig. 7)

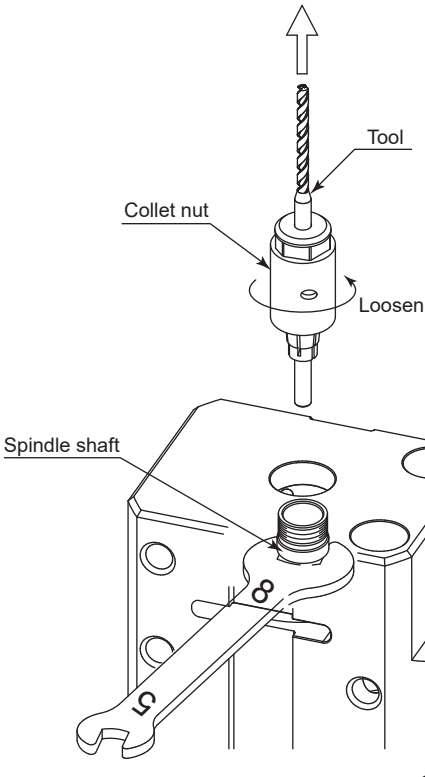

Fig. 4

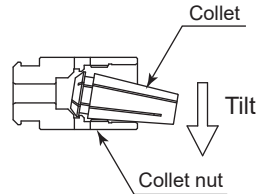

Fig. 5

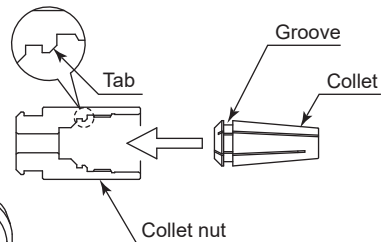

Fig. 6

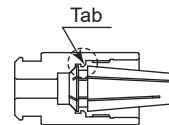

Fig. 7

10. INSTALLING THE HIGH-PRESSURE PUMP, COOLANT HOSE AND FITTINGS

⚠ WARNING

- When using coolant, check the operating pressure before connecting the coolant hose and fittings. If the maximum operating pressure of the coolant hose or fittings is exceeded, they could burst and cause injury.
- Connect the coolant hose and fittings securely. A coolant leak could cause injury or damage the device.
- When using an oil-based coolant, the coolant may be dispersed as a fine mist that could ignite. Implement fire prevention measures such as the use of dust collectors and automatic fire extinguishers.

⚠ CAUTION

- A high-pressure pump, filter and high-pressure coolant hoses are required in order to use this spindle. Procure these items separately before use. Install a relief valve or a safety valve as a safety measure.
- Install the manifold block in the machine tool, and connect the manifold block to this spindle using a high-pressure coolant hose. Allow some extra length in the hose to prevent the hose and fittings from being damaged if the machine tool table is moved.
- The high-pressure pump, filter and high-pressure coolant hose serial numbers are examples of those that we use. Select and prepare the items with the specifications that you require. Read each Operation Manual for the high-pressure pump, filter and high-pressure coolant hose that you use.

< Reference example of recommended items to prepare >

Item	Product Number (Example)	Manufacturer
High-pressure pump	Hydro pump • CHP150-1200	RIX CORPORATION
Intake filter, intake hose	(CHP150-1200 accessory)	RIX CORPORATION
Filter	Line filter • TM-C-04-2-3CH	Taisei Kogyo Co., Ltd.
High-pressure coolant hose	NH hose • NH3-K6-□-K6	ASK Corporation
High-pressure coolant fitting	Swagelok Tube fitting • SS-6M0-2-2PR (included with this spindle)	Swagelok Company
Coolant hose Hose fitting	FX series metal hose • SS-FX4TM6TM6-□CM	Swagelok Company
	Levex series hose • NWP3506	The Yokohama Rubber Co., Ltd.
Manifold block	Block manifold • BMZSMP4-Q2-G2	MISUMI Group Inc.
Relief valve	Pressure relief valve • SS-4R3A5-RT Spring kit • 177-R3A-K1-F	Swagelok Company

*Prepare appropriate fittings for connections.

10 - 1 Installing and Connecting the High-pressure Pump

- (1) Install the manifold block so that it does not interfere with other components in the machine tool.
- (2) Install the high-pressure pump, and place the intake filter in the coolant tank of the machine tool.
- (3) Install the filter (filtration accuracy of $5\ \mu\text{m}$ or less) and connect it to the high-pressure pump, the relief valve, and the manifold block with the coolant hose and fittings.
- (4) Connect the relief valve to the high-pressure pump or high-pressure pump flow path, and connect the coolant hose to the discharge side of the relief valve. The coolant hose should be installed so that the coolant can be discharged into the coolant tank.

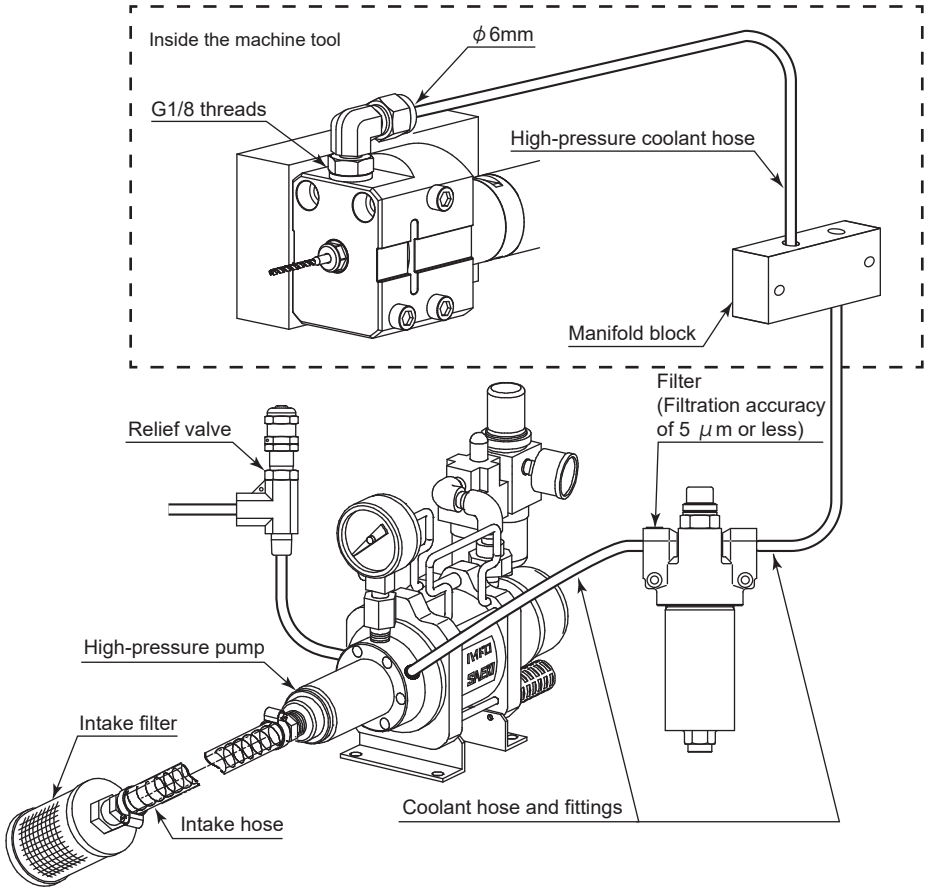

Fig. 8 Coolant hose and fitting connection example

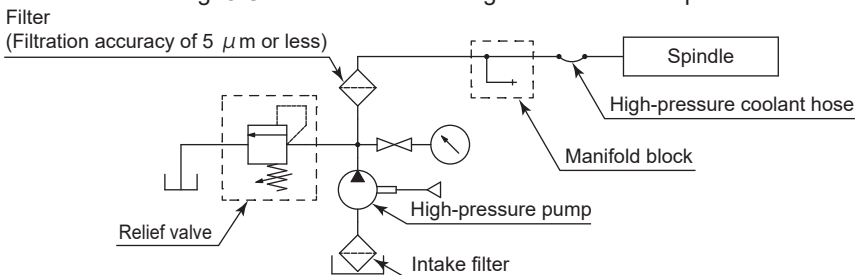

Fig. 9 Reference circuit diagram

10 - 2 Adjusting the High-pressure Coolant Fitting Angle

- (1) Loosen the lock nut of the high-pressure coolant fitting.
- (2) Adjust the high-pressure coolant fitting to an angle at which the high-pressure coolant hose is easy to connect.
- (3) Tighten the lock nut to secure the high-pressure coolant fitting.

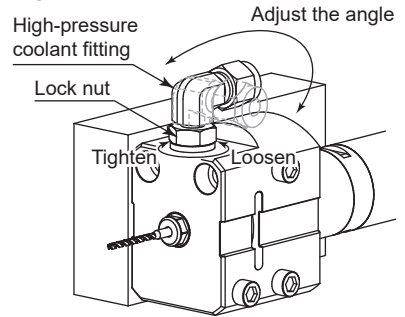

Fig. 10

10 - 3 Connecting the High-pressure Coolant Hose

- (1) Insert the high-pressure coolant hose (diameter $\phi 6$ mm) fully into the coolant supply port (diameter $\phi 6$ mm), and turn the joint nut clockwise to tighten it. (Fig. 11)

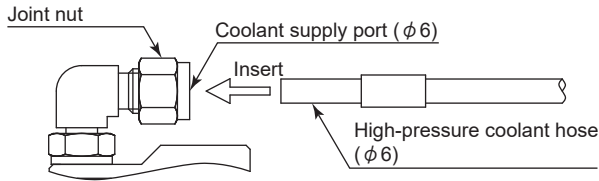

Fig. 11

- (2) Fit an adjustable wrench on the elbow surface (shaded area) of the high-pressure coolant fitting to hold it in place, and use another adjustable wrench to tighten the joint nut 1-1/4 turns. (Fig. 12)

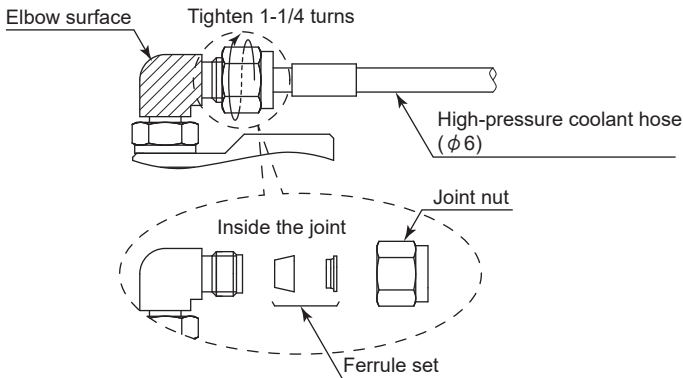

Fig. 12

< Replacing the high-pressure coolant fitting >

- (1) Loosen the lock nut of the high-pressure coolant fitting.
- (2) Fit an adjustable wrench on the elbow surface (shaded area) of the high-pressure coolant fitting, and turn it counterclockwise to remove the high-pressure coolant fitting.
- (3) Install the new high-pressure coolant hose and fitting to the G1/8 threads on the spindle.

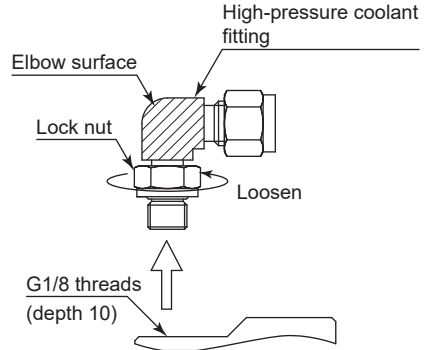

Fig. 13

10 - 4 Disconnecting and Reconnecting the High-pressure Coolant Hose

10 - 4 - 1 Disconnecting the Hose

- (1) Before loosening the joint nut, put a mark on the high-pressure coolant hose (diameter $\phi 6$ mm) at the end of the joint nut.
- (2) Draw a straight line on the flat part of the joint nut and the elbow surface of the high-pressure coolant fitting. (This line will be used later to check the position of the joint nut when it is retightened.)
- (3) Loosen the joint nut and disconnect the high-pressure coolant hose (diameter $\phi 6$ mm). (The ferrule set is fastened to the high-pressure coolant hose.)

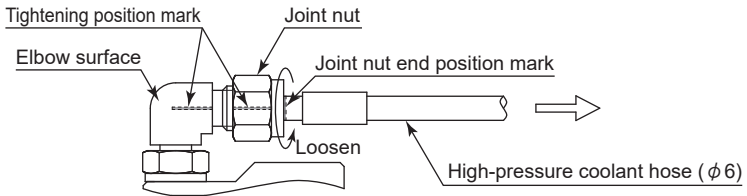

Fig. 14

10 - 4 - 2 Reconnecting the Hose

- (1) Insert the high-pressure coolant hose (diameter $\phi 6$ mm) so that the tapered surface of the ferrule set fastened to the high-pressure coolant hose (diameter $\phi 6$ mm) fits tightly against the tapered surface of the high-pressure coolant fitting. (Fig. 15)

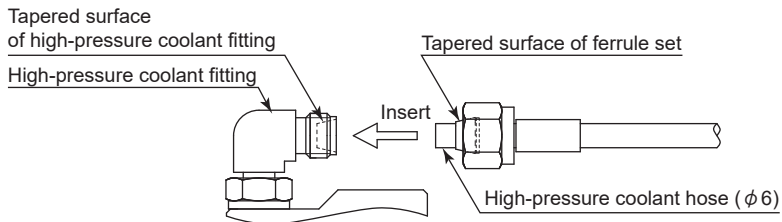

Fig. 15

- (2) Fit an adjustable wrench on the elbow surface (shaded area) of the high-pressure coolant fitting to hold it in place, and use another adjustable wrench to tighten the joint nut to its original tightening position. (Check that the matching lines are aligned and the end of the joint nut is aligned with the mark on the hose). (Fig. 16)

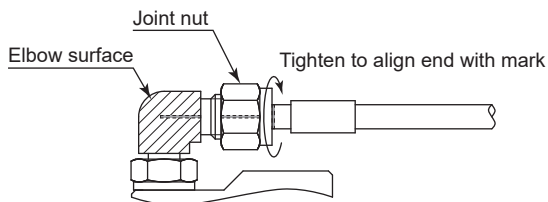

Fig. 16

- (3) Tighten the joint nut slightly more than before (by an amount equivalent to the thickness of the line). (Fig. 17)

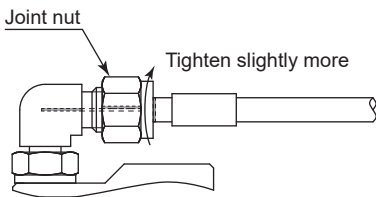

Fig. 17

11. SUPPLYING THE COOLANT

⚠ CAUTION

- A supply of coolant is required when using this spindle. If this spindle is used without supplying coolant, the generated heat could damage the components.
- Use coolant with an ISO viscosity grade of VG 32 or lower.
- Supply cooling air from the motor before supplying the coolant. If the coolant is supplied without first supplying the coolant air, the air purge will be lost and the coolant may enter the spindle and cause damage.
- Make sure that coolant passes through a filter with a filtration accuracy of 5 µm or less before it is supplied to the spindle.

11 - 1 Operation Procedure

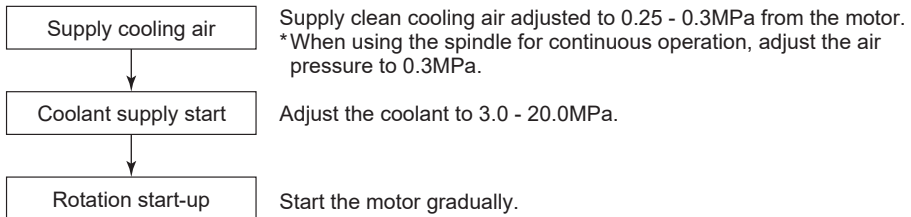

11 - 2 Stop Procedure

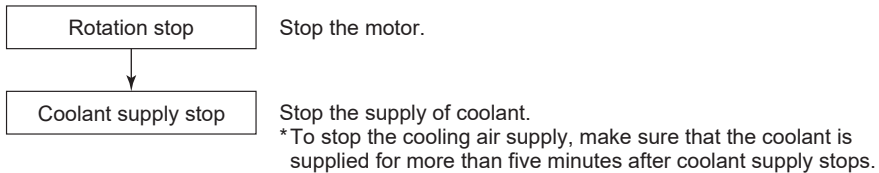

12. INSTALLING THE SPINDLE

⚠ WARNING

When installing the spindle, make sure that the fixed base is grounded to the machine tool in order to avoid the risk of an electric shock.

⚠ CAUTION

- Do not damage or subject the spindle to impact when installing it. Doing so may cause the components to malfunction.
- Never fasten a sleeve over the spindle body housing (diameter ϕ 30 mm) section when installing the spindle.

Install the spindle by using the mounting holes on the body, and do not fasten a sleeve over the body housing section. This is designed to eliminate deformation/damage of the spindle when performing the installation.

< Using the mounting holes (front) >

- (1) Insert the spindle body housing (diameter $\phi 30$ mm) section into the fixed base of the machine tool.
- (2) Secure the spindle through the mounting holes (2 locations) using the fastening bolts (M6). (Fig. 18)

< Using the mounting holes (rear) >

- (1) Insert the spindle body housing (diameter $\phi 30$ mm) section into the fixed base of the machine tool.
- (2) Secure the spindle through the mounting holes (2 locations) using the fastening bolts (M8). (Fig. 19)

< When using the mounting holes (side) >

- (1) Installing from the spindle side
Secure the spindle through the mounting holes (3 locations) using the fastening bolts (M5). (Fig. 20)
- (2) Installing from the mounting plate side
Secure the spindle through the mounting holes (3 locations) on the mounting plate side, using the fastening bolts (M6). (Fig. 21)

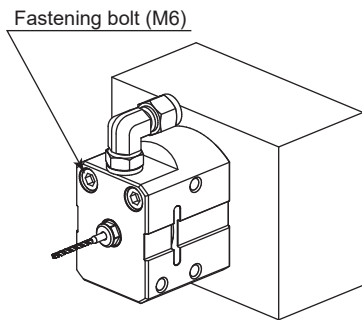

Fig. 18

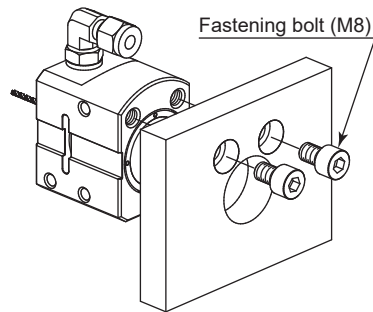

Fig. 19

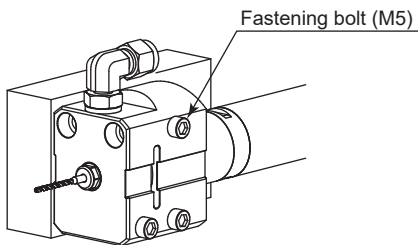

Fig. 20

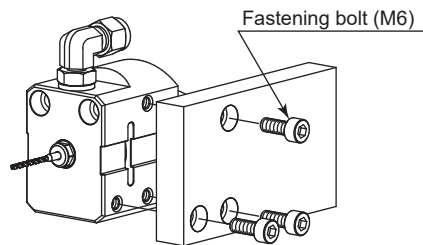

Fig. 21

13. BREAK-IN PROCEDURE

During transportation, storage or installation, the grease inside the bearings will settle. If the spindle is suddenly run at high-speed, excessive heat may cause bearing damage. Before operating for the first time after installation, repair, or a long period of non-operation, follow the break-in procedure detailed in steps 1 to 4 of Table. 2.

Table. 2

Step	1	2	3	4
Rotation Speed (min^{-1})	5,000	10,000	20,000	30,000
Rotation Time (min)	5	5	5	5
Items to Check	Coolant is supplied at pressure of approx. 3 MPa			

14. CAUTIONS WHEN USING CUTTING TOOLS

⚠ CAUTION

- Refer to the following formula for the maximum spindle rotation speed when using a drill or an end mill.

$$\text{Rotation speed (min}^{-1}\text{)} = \frac{1,000 \times \text{Cutting speed (m/min)}}{3.14 \times \text{Cutting tool diameter (mm)}}$$

- Keep the overhang length to a minimum when installing the cutting tool. If the overhang length is too long, the cutting tool may bend and cause injury.
- When using a drill, pre-center hole or pilot hole drilling is recommended to prevent damages and give more accuracy in drill locations.

- (1) The spindle RPM depends on the tool diameter and the workpiece material.
- (2) Please follow the manufacturer's recommended feeds and speeds.
Using tools outside of the manufacturer's maximum recommended rotational speed may cause damage to the spindle or injury to the operator.
- (3) When increasing the cutting tool overhang, reduce the motor speed. (Table. 3, Table. 4)
- (4) Always clean the tool shank before installing the tool in the spindle.
Foreign matter in the collet or collet nut may cause excessive run-out that could damage the cutting tool or spindle.
- (5) Do not strike, drop or disassemble the spindle.

Table. 3 Relationship Between Drill Overhang Length and RPM

Overhang Length (mm)	Max RPM
Drill diameter x 10	100% of the RPM
Drill diameter x 20	60% of the RPM
Drill diameter x 20 or more	30% or less of the RPM

Table. 4 Relationship Between End Mill Overhang Length and RPM

Overhang Length (mm)	Max RPM
Shank diameter x 5	100% of the RPM
Shank diameter x 10	50% of the RPM
Shank diameter x 10 or more	20% or less of the RPM

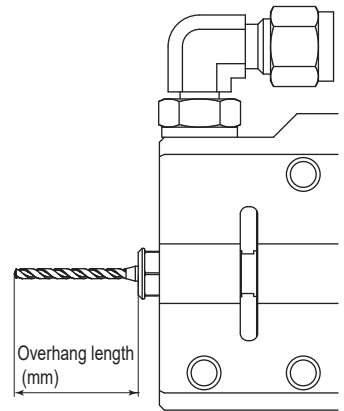

Fig. 22

15. TROUBLESHOOTING

In the event of any problems or concerns, please check the following before contacting your dealer.

Trouble	Cause	Inspection / Corrective Action
Spindle does not run.	The ball bearings are damaged.	Replace the ball bearings. (Return to NAKANISHI dealer service.)
	Motor is broken.	Replace the motor. (Return to NAKANISHI dealer service.)
	Collet nut contact or seizure occurred.	Replace the collet nut. Or, replace the spindle. (Return to NAKANISHI dealer service.)
Overheating during rotation.	Cutting debris has contaminated the ball bearings, and the ball bearings are damaged.	Replace the ball bearings. (Return to NAKANISHI dealer service.)
Abnormal vibration or noise during rotation.	Using bent tool.	Replace the cutting tool.
	Cutting debris has contaminated the ball bearings.	Replace the ball bearings. (Return to NAKANISHI dealer service.)
	The ball bearings are worn.	
Tool slippage.	Collet or collet nut is not correctly installed.	Check and clean the collet and collet nut, then properly retighten the collet.
	The collet and collet nut are worn.	Replace the collet and collet nut.
Excessive tool run-out.	The cutting tool is bent.	Replace the cutting tool.
	Collet nut is not correctly installed.	Secure the collet and collet nut correctly.
	The collet and collet nut are worn.	Replace the collet and collet nut.
	Inside of the spindle is worn.	Replace the spindle shaft. (Return to NAKANISHI dealer service.)
	Debris inside the collet, collet nut or spindle.	Clean the collet, collet nut and the inside of the spindle.
	The ball bearings are worn.	Replace the ball bearings. (Return to NAKANISHI dealer service.)
Coolant is not discharged from the end of the cutting tool.	The cutting tool is damaged or clogged.	Replace the cutting tool.
	Insufficient coolant pressure.	Check and adjust the coolant pressure.
	High-pressure pump failed.	Contact the manufacturer for repair.
	Coolant filter is clogged.	Clean or replace the filter.

Refer also to the E3000 CONTROLLER Operation Manual.

16. DISPOSAL OF THE SPINDLE

When disposal of this spindle is necessary, follow the instructions from your local government agency for proper disposal of industrial components.

株式会社ナカニシ www.nakanishi-inc.com

〒322-8666 栃木県鹿沼市下日向700
TEL: 0289-64-3380 FAX: 0289-62-5636

NAKANISHI INC.  www.nakanishi-inc.com

700 Shimohinata, Kanuma, Tochigi 322-8666, Japan

NSK America Corp. www.nskamericacorp.com

1800 Global Parkway, Hoffman Estates, IL 60192, USA

NSK Europe GmbH 

Elly-Beinhorn-Strasse 8, 65760 Eschborn, Germany

NSK United Kingdom Ltd. UK Authorised Representative

Office 4, Gateway 1000, Arlington Business Park, Whittle Way, Stevenage, SG1 2FP, UK

本書の内容は、改善のため予告なしに変更することがあります。
Contents are subject to change without notice.

取扱説明書の
ダウンロード
Download
operation
manual



ウェブサイト
Our website



発行日/Issued Date: 2021.06.24
印刷日/Printed Date: 2021.06.28 002 ヤ