

E2280 CONTROLLER

取扱説明書 / OPERATION MANUAL

日本語 : P1- P55/ English : P57- P114/ French : P117- P121

OM-K0681



Thank you for purchasing the E2280 Ultra-Precision, High-Speed Spindle System. The E2280 system was designed for use on CNC lathes, robots, NC lathes and special purpose machines. The motor, spindle and E2280 CONTROLLER are designed to work as an integrated system capable of 50,000min⁻¹ (rpm). This system utilizes air to cool the motor and protect the spindle. Always use an Air Line Kit to ensure clean, dry, properly regulated air is supplied to the motor and spindle. The E2280 system is capable of being used with coolants and cutting lubricants. Read this and all the associated component Operation Manuals carefully before use. Always keep this Operation Manual in a place where a user can referred to for reference at any time.

*In this Operation Manual, spindle and motor are collectively called motor spindle.

CONTENTS

IMPORTANT INSTRUCTIONS AND WARNING - Electric Devices	P58
1 . CAUTIONS FOR HANDLING AND OPERATION	P59
2 . BASIC PACKAGE	P62
3 . WARRANTY	P63
4 . CONTACT US	P63
5 . FEATURES	P63
6 . SPECIFICATIONS AND DIMENSIONS	P64
7 . SYSTEM CHART	P65
8 . TORQUE CHARACTERISTICS	P66
9 . CONTROL PANEL FEATURES	P67
10. POWER CORD CONNECTION	P68
11. REPLACING FUSES	P70
12. CONTROLLER MOUNTING BRACKET INSTALLATION	P70
13. MOTOR CORD CONNECTION	P71
14. AIR HOSE CONNECTION	P71
15. OPERATION PROCEDURES	P73
16. EXTERNAL INPUT / OUTPUT CONNECTOR	P80
17. PROTECT FUNCTION	P93
18. SETTING OF OPERATING PARAMETERS	P96
19. BREAK IN PROCEDURE	P110
20. TROUBLESHOOTING	P111
21. DISPOSAL OF THE CONTROLLER	P114

IMPORTANT INSTRUCTIONS AND WARNING - Electric Devices

WARNING!

When using electric tools, basic safety precautions should always be followed to reduce the risk of fire, electrical shock and personal injury.

Read all these instructions before operating this product and save these instructions.

A. GROUNDING INSTRUCTIONS

1. In the event of a malfunction or breakdown, grounding provides a path of least resistance for electric current to reduce the risk of electric shock. This tool is equipped with an electric cord with a grounding conductor.
2. Improper connection of the grounding conductor can result in electric shock. The conductor with insulation having an outer surface that is green with yellow stripes is the grounding conductor. If repair or replacement of the electric cord is necessary, do not connect the grounding conductor to a live terminal.
3. Check with a qualified electrician or service person if the grounding instructions are not completely understood, or if in doubt as to whether the tool is properly grounded.
4. Repair or replace damaged or worn electrical cord immediately.

B. OTHER WARNING INSTRUCTIONS

1. For your own safety read instruction manual before operating this tool.
2. Replace cracked collet or collet nut immediately.
3. Do not over tighten the collet nut.
4. Use only NAKANISHI manufactured collets and arbors for grinding and sawing applications.
5. REMOVE ADJUSTING KEYS AND WRENCHES. Always check to see that keys and adjusting wrenches are removed from tool before turning the units Main Power Switch on.
6. KEEP WORK AREA CLEAN. Cluttered areas and benches invite accidents.
7. DO NOT USE IN DANGEROUS ENVIRONMENTS. Don't use power tools in damp or wet locations, or expose them to rain.
8. Keep work area well lighted.
9. There is a risk of injury due to accidental starting. Do not use in an area where children may be present.
10. DO NOT FORCE THE TOOL. Never use a tool for an application it was not designed for.
11. USE THE CORRECT TOOL. Do not force tools or attachments to do a job for which it was not designed.
12. WEAR PROPER APPAREL. Do not wear loose clothing, gloves, neck ties, rings, bracelets, or other jewelry that might get caught in moving parts. Non-slip footwear is recommended. Wear protective hair covering to contain long hair.
13. ALWAYS USE SAFETY GLASSES. Everyday eyeglasses only have impact resistant lenses, they are NOT safety glasses. Also use face or dust mask if cutting operation is dusty.
14. SECURE YOUR WORK. Use clamps or a vise to hold work securely at all times.
15. MAINTAIN TOOLS WITH CARE. Keep tools sharp and clean for best performance and to reduce the risk of injury. Follow instructions for changing accessories.
16. DISCONNECT TOOLS before servicing or when changing accessories, such as blades, cutters etc.
17. TO REDUCE THE RISK OR UNINTENTIONAL STARTING. Make sure Main Power Switch is in OFF position.
18. NEVER LEAVE TOOLS RUNNING UNATTENDED. TURN POWER OFF. Don't leave the tool until it comes to a complete stop.
19. For recommended operating speeds for various applications, please follow recommendations of the cutting tool manufacturer.

1. CAUTIONS FOR HANDLING AND OPERATION

- Read these warnings and cautions carefully and only use in the manner intended.
- These warnings and cautions are intended to avoid potential hazards that could result in personal injury or damage to the device. These are instructions are classified as follows in accordance with the seriousness of the risk.

Class	Degree of Risk
⚠ DANGER	Existence of a hazard that could result in personal death or serious injury, if the safety precautions are not followed.
⚠ WARNING	A safety hazard that could result in bodily injury or damage to the device if the safety instructions are not properly followed.
⚠ CAUTION	A hazard that could result in light or moderate bodily injury or damage to the device if the safety instructions are not followed.

⚠ **DANGER**

- ① NAKANISHI warns all end-users not to remove the Power Cord or Motor Cord while the Control Power is ON. Not following these instructions may lead to serious injury or death due to electric shock.
- ② Make sure the input power supply is OFF before wiring. If the incoming power supply is ON, it may cause risk that leads to death or serious injury by electrical shock.
- ③ Be sure to connect the ground wire to the earth ground. Insufficient grounding could cause an electric shock or malfunction.
- ④ Be sure to connect the ground wire of the Power Cord to the AC input power Terminal Block (Earth Mark). Insufficient grounding could cause an electric shock or fire and malfunction.

⚠ **WARNING**

- ① The CONTROLLER is not a hand tool. It is designed to be used on a CNC lathe or special purpose machines.
- ② Do not touch the cutting tool while it is running. It is very dangerous.
- ③ Wear safety glasses, dust mask, and use a protective cover around the motor spindle whenever the motor spindle is rotating.
- ④ Never operate the Control Panel, connect, disconnect or touch the Power Cord or Motor Cord Plug with wet hands. This may cause an electric shock.
- ⑤ Never operate or handle the CONTROLLER and motor spindle until you have thoroughly read the Operation Manuals and safe operation has been confirmed.
 - 1) To prevent injuries / damages, check the CONTROLLER, motor spindle and cutting tool for proper installation, then operate the CONTROLLER and motor spindle.
 - 2) Before disconnecting the CONTROLLER or motor spindle, always turn the control power OFF and turn the compressed air supply to the CONTROLLER OFF. Then it is safe to remove the CONTROLLER and motor spindle.
- ⑥ Do not use in dangerous environments. Protect the CONTROLLER from moisture, coolant spray, oil mist, metallic dust or other contaminants. Failure to protect CONTROLLER can result in damage to internal components and injury to the operator.
- ⑦ To protect the CONTROLLER or electrical wiring from a possible short circuit, place a circuit breaker (MCCB) between the power source and the AC POWER Input Terminal of the CONTROLLER. Select a 5A circuit breaker, complying with the safety standards UL 489 / EN 60947.
- ⑧ Be sure to turn OFF the Main Power Switch of the CONTROLLER before connecting or disconnecting the connector or plug.
- ⑨ Check to ensure that the supply voltage is the same as the CONTROLLER rated voltage.

WARNING

- ⑩ When installing a tool, tighten the collet correctly and check again the collet and collet nut before use. Do not over-tighten the collet. This may cause damage to the spindle.
- ⑪ Do not use bent, broken, chipped, out of round or sub-standard tools, as this may cause them to shatter or explode. Tools with fractures or a bent shank will cause injury to the operator. When using a new tool, rotate it in a low speed and increase speed gradually for safety.
- ⑫ Do not exceed the recommended maximum allowable speed of the tool. For your safety, use speeds below the maximum allowable speed.
- ⑬ Do not apply excessive force. This may cause injury to the operator by slippage or damage of the tool, or loss of concentricity and precision of the motor spindle.
- ⑭ When installing the motor spindle, make sure the Main Power Switch of the CONTROLLER turned OFF before installing.
- ⑮ Whenever installing the motor spindle to a fixed metal base, ensure that the fixed metal base is grounded in order to avoid the risk of an electric shock.
- ⑯ Do not use with held horizontally. This may cause malfunction and damage.
- ⑰ Use a power cable that satisfies the prescribed safety standards and local electrical codes for your country. Also select the proper cable size considering the input voltage and current.

CAUTION

- ① A motor cooling and spindle purge air is required to operate the system correctly. The input air line must be connected to the air inlet joint on the front of the CONTROLLER. Air pressure between 0.25 - 0.3MPa (36.3 - 43.5psi) must be supplied.
- ② The motor spindle requires air for cooling and purging. Ensure that this air supply is clean and dry. Introduction of dust, moisture and other contaminants into the CONTROLLER and motor spindle will cause damage to the internal components.
- ③ If water or oil is allowed to enter the CONTROLLER, failure of the CONTROLLER may result.
- ④ Do not hit, drop or subject the motor spindle or CONTROLLER to any type of shock. This will cause damage to internal components and result in a malfunction.
- ⑤ Do not disassemble, modify or attempt to repair the CONTROLLER or motor spindle. Additional damage will occur to the internal components. Service must be performed by NSK NAKANISHI or an authorized service center.
- ⑥ Never place the air vents upward or block the air vents of the CONTROLLER when installing the CONTROLLER.
- ⑦ Motor will make a sudden stop when Error LED lights or error output signal is generated. Check and correct the cause of the malfunction before continuing use. Failure to correct the problem will result in damage to the CONTROLLER and motor spindle.
- ⑧ When the Warning LED on the CONTROLLER blinks, conditions exist that could result in dangerous operation. Check operating conditions and continue to use only after correcting the problem.
- ⑨ When using the CONTROLLER continuously, refer to continuous area on torque Characteristics Graph and check the LOAD Monitor LED for a maximum output (3 Green Lamps).
- ⑩ Do not install the CONTROLLER next to RF noise sources, as malfunctions can occur.
- ⑪ If smoke, noise or strange odors emanate from the CONTROLLER or motor spindle, immediately turn OFF the Main Power Switch.
- ⑫ Do not place anything on top of the CONTROLLER.
- ⑬ When installing the CONTROLLER, never place them in areas where vibration and shock are present or possible. This may cause a malfunction to occur.
- ⑭ When using in a place where the power conditions are poor, take measures to enable a supplied input power within the specified voltage fluctuation.
- ⑮ Do not place the CONTROLLER near any source of heat. The temperature inside the CONTROLLER will rise, resulting in a CONTROLLER failure.
- ⑯ Attach the provided Connector Cover for safety and dust proofing when not using Input / Output Connector A / B.

CAUTION







- ⑰ Attach the provided connector cap for safety and dust proofing when not using the Motor Connector No. 1 / No. 2.
- ⑱ Do not press the switches on the operation panel of the CONTROLLER with a sharp-pointed tool.
- ⑲ When disposal of a CONTROLLER is necessary, follow the instructions from your local government agency and dispose as an industrial waste.
- ⑳ Be sure to clean the collet and collet nut, the inside of the spindle before replacing the tool. If ground particles or metal chips stick to the inside of the spindle or the collet, damage to the collet or the spindle can occur due to the loss of precision.
- ㉑ Always clean the tool shank before installing the tool in the spindle.
- ㉒ When sizing the correct collet size to the tool shank diameter, a tolerance of $+0 \sim -0.01\text{mm}$ is strongly recommended. A tool shank within the $+0 \sim -0.1\text{mm}$ range is mountable, however, this may cause poor concentricity and or insufficient tool shank gripping force.
- ㉓ Select suitable products or tools for all applications. Do not exceed the capabilities of the motor spindle or tools.
- ㉔ Do not stop the supplied cooling air to the motor spindle during operation of the machine. Removing the air pressure from the motor spindle causes a loss of purging, allowing the motor spindle to ingest coolant and debris. This will cause damage to the motor spindle.
- ㉕ Carefully direct coolant spray directly on the tool. Do not spray directly on the motor spindle and collet nut. Large amounts of coolant sprayed directly on the motor spindle and collet nut may cause excess load of the motor spindle causing a loss of durability and longevity of the motor spindle.
- ㉖ Stop working immediately when abnormal rotation or unusual vibrations are observed. Immediately, please check the content of section P111 " 20. TROUBLESHOOTING ".
- ㉗ Always check if the tool, collet, collet nut, connection hose and supply air hose for damage before and after operating.
- ㉘ If the collet or collet nut show signs of wear or damage, replace them before a malfunction or additional damage occurs.
- ㉙ After installation, repair, initial operation, or long periods of non operation, please refer to Operation Manual on the motor spindle detailed in " BREAK-IN PROCEDURE ". When checking the motor spindle, no vibration or unusual sound should be observed during rotation.
- ㉚ Secure the power cord by use of the power cord hook after connecting the power cord to the Main Power Inlet with Power Supply Fuses.
- ㉛ Setting parameters allows the motor to run without motor cooling. When using, be aware of the possibility of overheating.
- ㉜ Be sure to attach the Brackets to the CONTROLLER when there is a possibility of the CONTROLLER to fall.
- ㉝ Confirm the maximum speed of the motor spindle in the operation manual supplied with it before setting its speed on the CONTROLLER. Excessive speed may cause damage to the motor spindle, and this may also cause the motor spindle to overheat and shorten its service life.
- ㉞ When using this CONTROLLER for mass production, please consider the purchase of an additional CONTROLLER to be used as a back-up in case of emergency.
- ㉟ Securely connect the compressor supply connection hose to the Air Line Kit, and connect the air hose to the Air Line Kit, the CONTROLLER and the motor spindle to avoid accidental disconnection during use.
- ㊱ Disconnect CONTROLLER from power before doing maintenance on replacing tools or fuses as specified.
- ㊲ Do not use in flammable or explosive atmospheres.
- ㊳ Send back to NSK NAKANISHI or an authorized service center for servicing / repair.
- ㊴ Use the CONTROLLER in pollution degree 2 environment.

2. BASIC PACKAGE

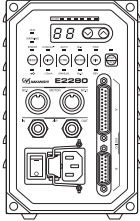
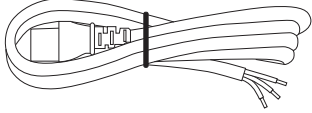
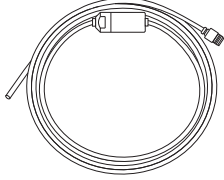
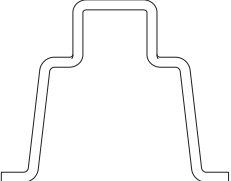
When opening the package, check if it includes all items listed in " Table. 1 Packing List Contents ".

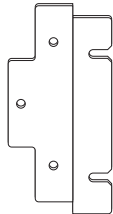
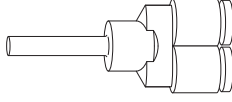
In the event of any shortage, please contact either NAKANISHI (see the " 4. CONTACT US " section) or your local dealer.

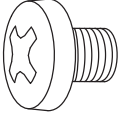
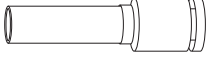
Table. 1 Packing List Contents

<p>E2280 CONTROLLER Main Body • • 1pc.</p> 	<p>Power Cord • • 1pc.</p> 	<p>φ6mm Air Hose with Filter • • 1pc.</p> 
<p>Power Cord Hook • • 1pc.</p> 	<p>Connector Cap • • 2pcs.</p> 	<p>Connector Cover A Connector Cover B • • 1pc. Each.*</p> 
<p>Bracket • • 2pcs. • • 1set</p> 	<p>Air branching joint • • 1pc.</p> 	<p>Fuse • • 2pcs. • • 1set</p> 
<p>Mounting Screw • • 6pcs.</p> 	<p>Reducer • • 1pc.</p> 	<p>Operation Manual • • 1set</p> 
<p>WARNING / Error Code Label • • 1set</p> 		

* The Connector Cap and Connector Cover A / B, are attached to the CONTROLLER.

3. WARRANTY

We provide a limited warranty for our products. We will repair or replace the products if the cause of failure is due to the following manufactures defects. Please contact us or your local distributor for details.

- (1) Defect in manufacturing.
- (2) Any shortage of components in the package.
- (3) Where damaged components are found when initially opening the package.
(This shall not apply if the damage was caused by the negligence of a customer.)

4. CONTACT US

For your safety and convenience when purchasing our products, we welcome your questions. If you have any questions about operation, maintenance and repair of the product, please contact us.

Contact Us

● For U.S. Market

Company Name : **NSK America Corp**
Industrial Div.
Business Hours : 8:30am to 17:00pm (CST)
(closed Saturday, Sunday and Public Holidays)
U.S. Toll Free No. : 800-585-4675
Telephone No. : 847-843-7664
Fax No. : 847-843-7622
Web Address : www.nskamericacorp.com

● For Other Markets

Company Name : **NAKANISHI INC.** 
Business Hours : 8:00am to 17:00pm
(closed Saturday, Sunday and Public Holidays)
Telephone No. : +81 (0) 289-64-3520
e-mail Address : webmaster-ie@nsk-nakanishi.co.jp

5. FEATURES

- ① A high-speed brushless motor is used to achieve a maximum speed of 50,000min⁻¹ (rpm) (when using EM25-5000-J4, EM25N-5000-J4, EM-2350J) and eliminate the need for motor brush maintenance.
- ② Speed control and protection functions utilize a high performance microprocessor.
- ③ Automatic control and monitoring of spindle functions are possible.
- ④ Wide speed range, 1,000 - 50,000min⁻¹ (rpm) makes high precision machining possible.
- ⑤ Compact CONTROLLER design allows easy installation in space restricted machines. Connectors and control panel are front mounted for easy access.
- ⑥ The CONTROLLER is capable of being connected to AC100V or AC240V power sources. The Auto Sensing feature reduces installation time and eliminates the possibility of connecting the wrong voltage.
- ⑦ The COTROLLER has a parameter function, which controls motor movement according to its use.
- ⑧ By setting the parameter (P9), Emergency Operating Function can be utilized. Using the open detection signal of the motor power line and the disconnect of the motor power line by safety relay, allows the E2280 CONTROLLER to establish a safe spindle system.
- ⑨ By setting parameter (PR), the CONTROLLER is capable of storing the last 5 Error Codes that were displayed. This allows Error Codes to be reviewed if no one is present when the error occurs. Error History will be stored to the CONTROLLER, even if the Main Power Switch is turned OFF.

6. SPECIFICATIONS AND DIMENSIONS

6 - 1 Specification of the CONTROLLER

Product Name		E2280 CONTROLLER
Model		NE314
Input Voltage		AC100 - 240V, 50 / 60Hz, 1PHASE, 1.45A
Output		AC28V, 0 - 0.83KHz, 3 PHASE, 2.3A
Over Voltage Category		Category II
Pollution Degree		Class 2
Speed Range		1,000 - 50,000min ⁻¹ (rpm)
External Control Signal	Input Signal	Input : Digital 8 (Photo Coupler) Analog 2
	Output Signal	Output : Photo Coupler, MOS Relay 10 Relay Contact 2, Analog 3
Protection Function		Excess Current, Over Voltage, Motor Sensor Malfunction, Motor Cord Disconnect, CONTROLLER Overheat, Brake Circuit Trouble, Rotor Lock, Low Air Pressure, Torque Over Load, External Control Signal Error, Incompatible Motor, Over Speed, Emergency Stop Error, Internal Memory Error
Weight		2.2kg
Dimensions		W 108 x D167.7 x H 176mm
Operation Environment	Temperature	0 - 40°C
	Humidity	MAX. 75% (No condensation)
	Atmospheric Pressure	800 - 1,060hPa
Transportation and Storage Environment	Temperature	-10 - 50°C
	Humidity	10 - 85%
	Atmospheric Pressure	500 - 1,060hPa
Height above Sea Level		Less than 2000m

6 - 2 Compatibility

(1) The E2280 CONTROLLER is compatible with the following overseas safety standard.

- Safety standard in North America (UL,CSA) 

UL 61010-1

CSA 61010-1

- EC Directive



Low Voltage Directive

IEC / EN 61010-1

EMC Directive

EMS : EN61000 - 6 - 2

EMI : EN61000 - 6 - 4

(2) The E2280 CONTROLLER is *RoHS Compliant.

*RoHS : Restriction of Hazardous Substances by the European Union (EU).

6 - 3 Outside View

*Below is an outside view with Brackets (Standard Accessory) attached.

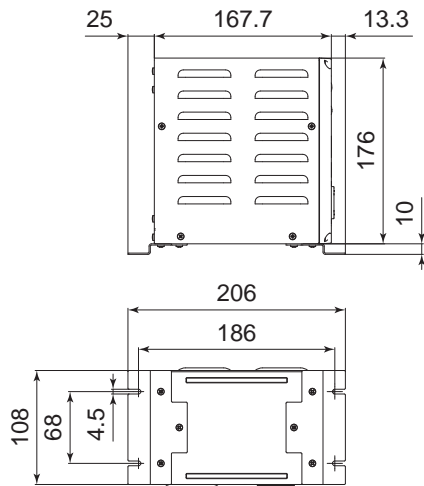

Fig. 1 Bottom Mounting

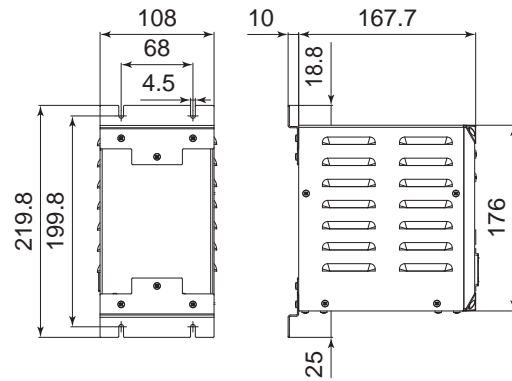

Fig. 2 Rear Mounting

7. SYSTEM CHART

7 - 1 $\phi 25$ System

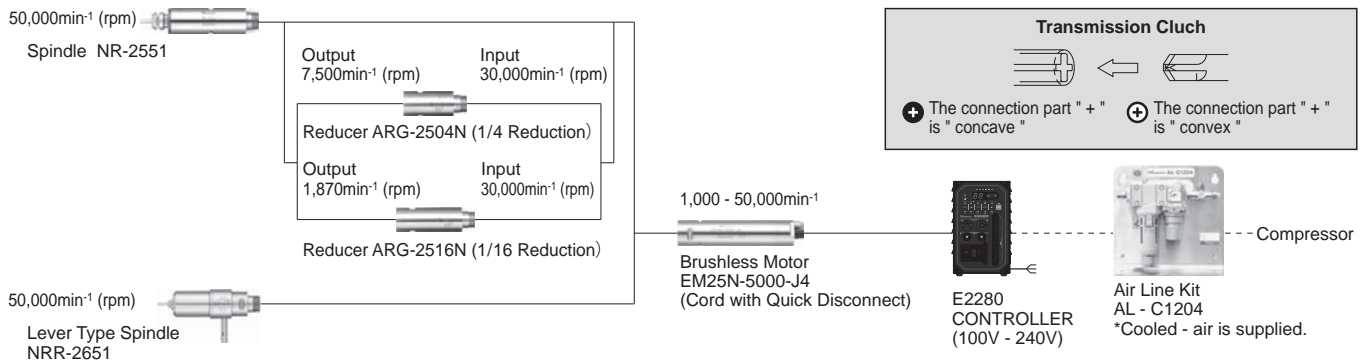

Fig. 3

7 - 2 $\phi 22.8$ System

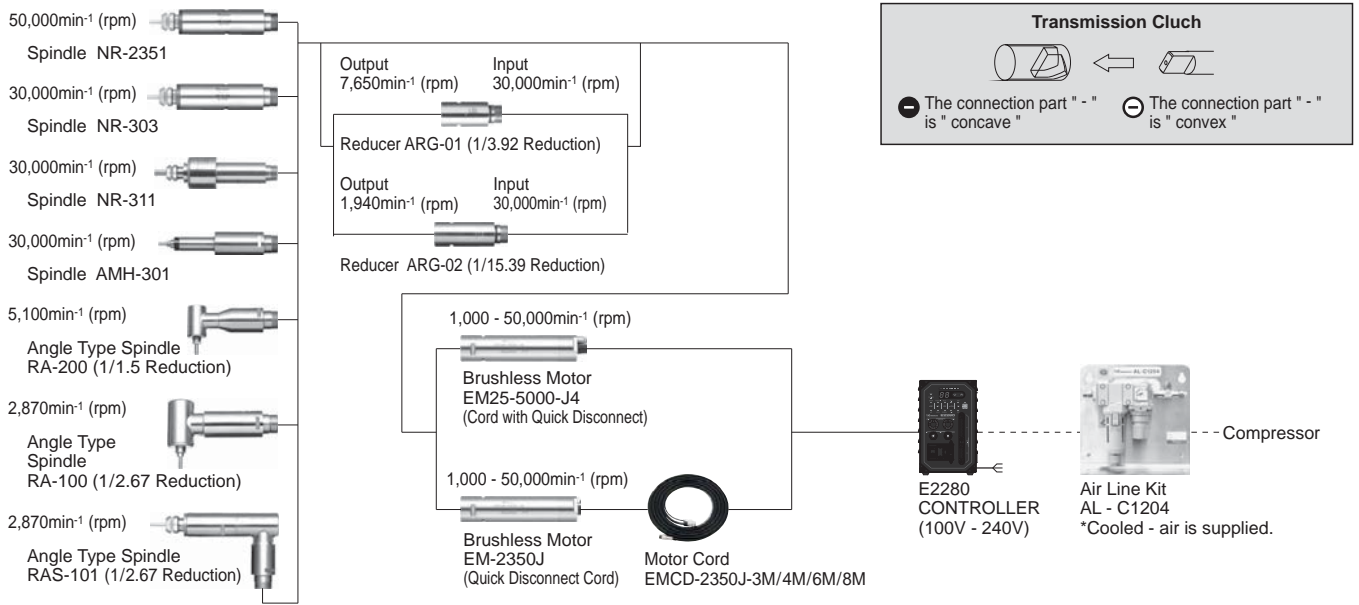

Fig. 4

8. TORQUE CHARACTERISTICS

EM25 - 5000 - J4 / EM25N - 5000 - J4 / EM - 2350J

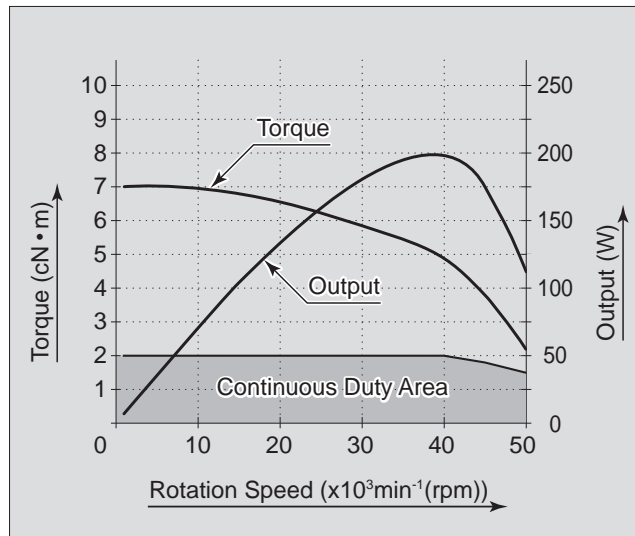

Fig. 5

9. CONTROL PANEL FEATURES

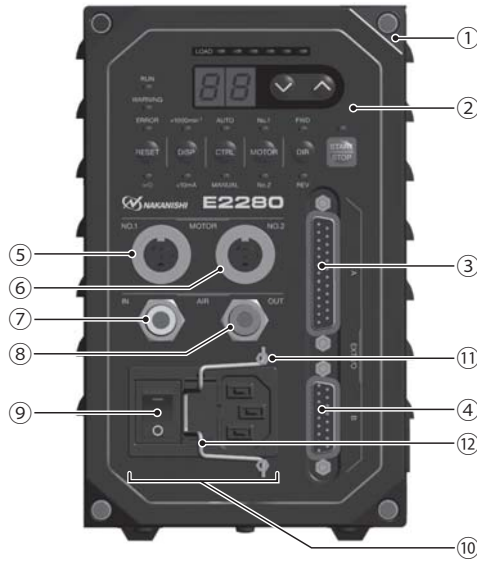

Fig. 6

① E2280 CONTROLLER

② Control Panel

③ Input / Output Connector A

Input / Output Connector A is for automatic control and monitoring of motor spindle system. Refer to P80 " 16 - 1 (1) Details of External Input / Output Connector A Signals " section.

Attach the provided Connector Cover A for safety and dust proofing, when not using Input / Output connector A.

④ Input / Output Connector B

Connector for automatic monitoring of emergency conditions.

Refer to P88 " 16 - 2 (1) Details of External Input / Output Connector B Signals " section.

Attach the provided Connector Cover B for safety and dust proofing, when not using Input / Output connector B.

⑤ Motor Connector No. 1

Connect the Motor Cord Plug of the motor spindle. Refer to P71 " 13. MOTOR CORD CONNECTION " section.

Attach the provided Connector Cap for safety and dust proofing, when not using Motor Connector No. 1.

⑥ Motor Connector No. 2

Connect the Motor Cord Plug of the motor spindle. Refer to P71 " 13. MOTOR CORD CONNECTION " section.

Attach the provided Connector Cap for safety and dust proofing, when not using Motor Connector No. 2.

⑦ Air Input Joint

Supply clean, dry, regulated air for motor cooling. Regulate air to between 0.25 - 0.3MPa (36.3 - 43.5psi). Max. Air Consumption is 30Nℓ/min. Air must be supplied to operate the system at maximum rpm. Refer to P71 " 14. AIR HOSE CONNECTION " section.

⚠ CAUTION

If the air pressure is too low the E2280 CONTROLLER will not operate.

⑧ Air Output Joint

Connect Air Hose to supply clean, dry, regulated air for motor spindle cooling and purging. Refer to P71 " 14. AIR HOSE CONNECTION " section.

In order to connect two motor spindles to the control unit, connect 4mm air hose (95mm) to air output joint on the rear of the control unit and branch the air by using the air branching joint.

⑨ Main Power Switch

ON / OFF main power source. The designation " I " Indicates ON. The designation " O " Indicates OFF.

⑩ Main Power Inlet with Power Supply Fuses

Insert the supplied power cord connector. Refer to P68 " 10. POWER CORD CONNECTION " section.

Two fuses (T1.6AL (250V)) have been installed. Make sure the properly rated and type of fuses are used when replacements are necessary. When replacing fuse, refer to P70 " 11. REPLACING FUSES " section.

⑪ Fixing Power Cord Hook Bar

⑫ Power Cord Hook (Standard Accessories)

Used for attaching the power cord connector to the Main Power Inlet securely.

Refer to P69 " 10 - 2 Power Cord Connector Connection " section.

10. POWER CORD CONNECTION

⚠ WARNING

The input power side of supplied CONTROLLER power cord does not have a male connector (Fig. 7). The CONTROLLER side has a female connector. Make sure the input power supply is OFF before wiring. If the input power supply is ON, it may cause risk of death or serious injury by electric shock.

⚠ CAUTION

Only use grounded power sources. Using a non-specified Power Cord, the risk of fire by over-heating of the cord is possible.

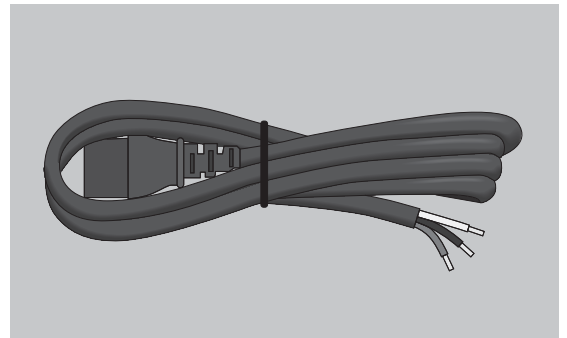

Fig. 7

10 - 1 Wiring of the power cord

⚠ CAUTION

- Be sure to connect the ground wire to the earth ground. Insufficient grounding could cause an electric shock or fire, and malfunction.
- When connecting the power cord to the AC Power Input Terminal Block, tighten the screw securely. Loose Terminal Screws to the AC Power Input Terminal Block will cause overheating leading to damage and fire in the CONTROLLER.

The power cord includes 3 colors of cords: white, black and yellow/green. Make sure to connect each cord to the AC Power Input Terminal Block, etc. securely. (Table. 2, Fig. 8)

Table. 2

Wire Color	AC Power Input Terminal Block connection position
White	Neutral line (N)
Black	Live line (L)
Green/Yellow	Ground wire (⊕)

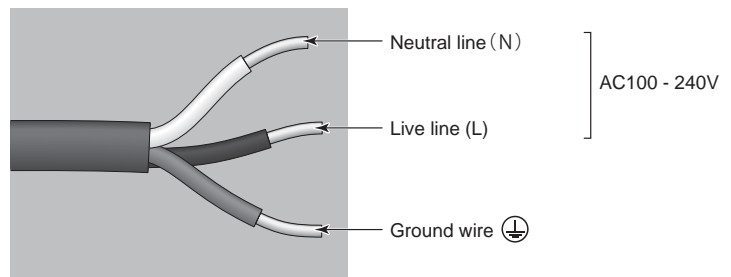

Fig. 8

10 - 2 Power Cord Connector Connection

⚠ CAUTION

- Reduce the risk of unintentional starting. Make sure the Main Power Switch ⑨ is in the OFF position before connecting the CONTROLLER or plugging the system in.
- When installing the CONTROLLER, provide space of approximately 10cm around the CONTROLLER for easy access to the air inlet and the Power Cord Connector.

- (1) Install the Power Cord Hook ⑫ to the Fixing Power Cord Hook Bar ⑪ (Refer to Fig. 9).
- (2) Insert the female plug into the main power inlet box (Refer to Fig. 10).
- (3) Secure the Power Cord Connector by use of Power Cord Hook ⑫ (Refer to Fig. 11).

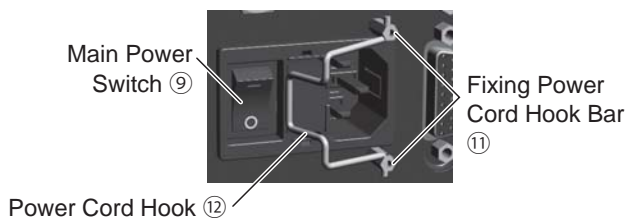

Fig. 9

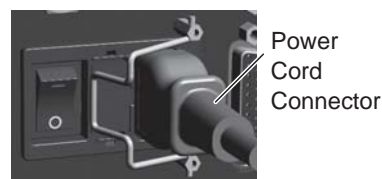

Fig. 10

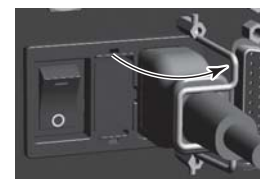

Fig. 11

11. REPLACING FUSES

⚠ WARNING

- Before removing the fuse holder and fuses, be sure that the Main Power Switch ⑨ is turned OFF and the Power Cord Connector has been removed from the CONTROLLER.
- Verify type and use only following the properly rated and type of fuse.
Specified fuses : T5A (250V) Part No. S506-5-R (Cooper Bussman Inc.)
- * Failure to use the proper type and rated fuse will result in fire, injury, electric shock and / or product damage.

- (1) Push on the clips on the top and bottom of the fuse holder and remove the fuse holder block.
- (2) Remove the bad fuse or fuses and replace with the proper type and rating of fuse by the input voltage being used.
- (3) Replace the fuse holder containing the fuses into the Main Power Inlet with Power Supply Fuses ⑩ and make sure it snaps in place.

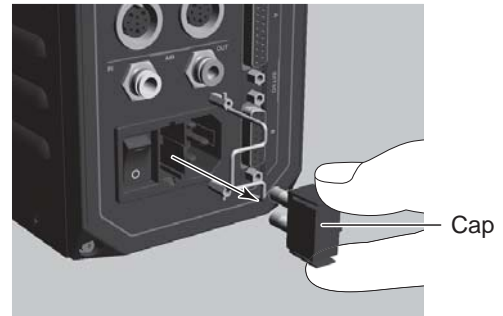

Fig. 12

12. CONTROLLER MOUNTING BRACKET INSTALLATION

⚠ CAUTION

- If there is a possibility for the CONTROLLER to move from its mounting location, for safety, be sure to secure it with the brackets provided.
- When installing the CONTROLLER, be sure to place air vents downward, away from debris. Protect the CONTROLLER (air vents and other connector) from cutting oil, mist oil, powder dust, other contaminants that can buildup heat and damage the internal components of the CONTROLLER.
- The Bracket can be installed on the " Bottom Mounting (Fig. 13) " and " Rear Mounting (Fig. 14) " of the CONTROLLER.

- (1) Attach the Installation Brackets (2pcs.) using the provided Mounting Screws (6pcs.).
- (2) Attach the CONTROLLER (Bracket's Slotted Area) to the machine using the provided Mounting Screws (6pcs.).

Bottom Mounting



Fig. 13

Rear Mounting

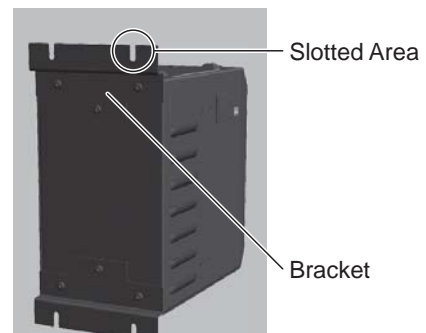

Fig. 14

13. MOTOR CORD CONNECTION

⚠ CAUTION

- Before connecting to the Motor Cord Plug, make sure the Main Power Switch ⑨ is turned OFF. If the Main Power Switch ⑨ is turned ON while connecting the Motor Cord Plug, damage may occur to the CONTROLLER.
- Two motor spindles can be connected to this CONTROLLER (Motor Connector No. 1, Motor Connector No. 2).
When only one Motor Connector is in use, make sure to attach the connector cap for safety.

- (1) Ensure the Alignment Pin is located upward (12 o'clock position).
- (2) Carefully insert the Alignment Pin into the Alignment Hole and push straight into the Motor Connectors ⑤ and ⑥ on the front of the CONTROLLER.
- (3) Tighten the Connector Nut.

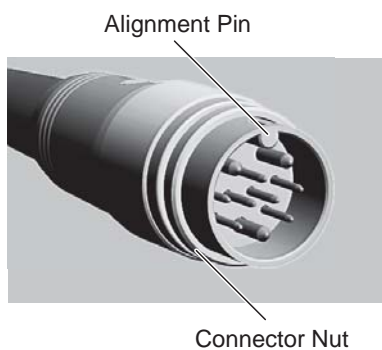

Fig. 15

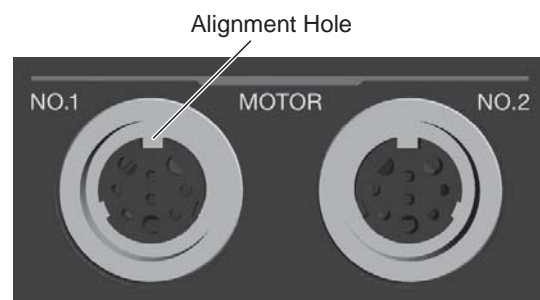

Fig. 16

14. AIR HOSE CONNECTION

⚠ CAUTION

When not using NAKANISHI Air Line Kit, make sure that the incoming air supply is dry, clean and properly regulated.

14 - 1 One Motor Spindle is connected to the CONTROLLER (Fig. 17)

- (1) Insert the provided ϕ 6mm Air Hose with Filter from the Air Line Kit AL-C1204 into the Air Input Joint ⑦ on the front of the CONTROLLER.
- (2) Insert one end of the provided ϕ 4mm cooling Air Hose into the back of the motor spindle.
- (3) Insert the other end of the ϕ 4mm cooling Air Hose into the Air Output Joint ⑧ on the front of the CONTROLLER using the provided Reducer (ϕ 6mm - ϕ 4mm Conversion Adaptor).

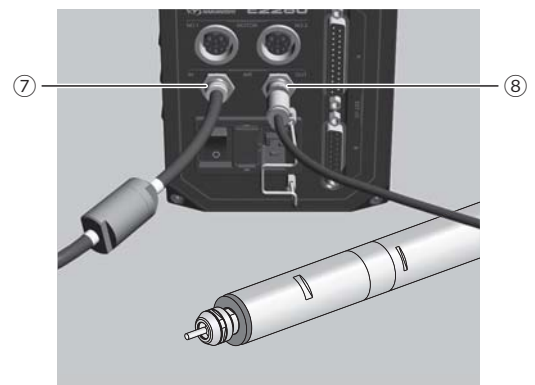

Fig. 17

14 - 2 Two Motor Spindles are connected to the CONTROLLER (Fig. 18)

- (1) Insert the provided ϕ 6mm Air Hose with Filter from the Air Line Kit AL-C1204 into the Air Input Joint ⑦ on the front of the CONTROLLER.
- (2) Insert the Air Branching Joint (standard accessories) to the Air Output Joint ⑧ .
- (3) Insert one end of the ϕ 4mm cooling Air Hoses (motor cord's standard accessories) into the Air Input Joint on back of the motor spindle.
- (4) Insert the other end of the ϕ 4mm cooling Air Hoses into the Air Branching Joint (standard accessories).

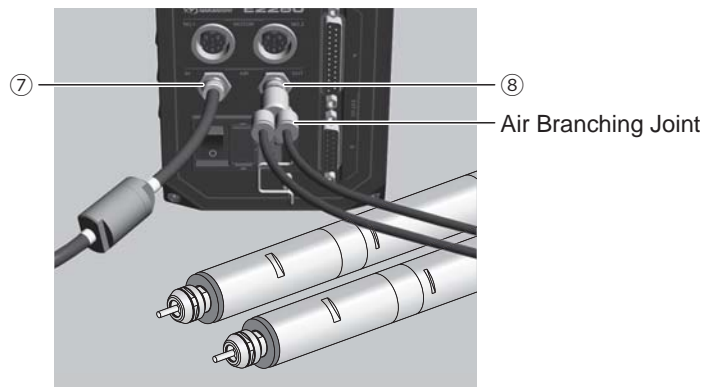

Fig. 18

14 - 3 Air Pressure Adjustment

Regulate air pressure between 0.25 - 0.30MPa (specified air pressure).

Setting parameter **(P9)** (refer to P108 " 18 - 4 ⑨ **(P9)** Selection of Air Input Monitoring Override " section), allows the motor to run at 30,000min⁻¹ (rpm) without motor cooling.

Running the motor spindle without cooling can cause premature failure due to high temperatures.

Limit the usage of parameter to " **(P9)** Selection of Air Input Monitoring Override " (startup motor without supplying cooling air) to only when supply cooling air is not suitable or available.

⚠ CAUTION

- If air pressure is too low, the motor will not operate.
If the supplied air pressure remains lower than the specified air pressure for 3 seconds or more while the motor is rotating, the motor will stop automatically. If the supplied air pressure becomes lower than the specified air pressure while the motor is rotating, Warning code " A1 " will be displayed on the Digital Speed Indicator ⑬ and a warning signal (WARNING) will be output.
- The cooling air also provides air purge protection to the motor spindle. If the Main Power Switch ⑨ is turned OFF, the cooling air will continue to flow.
- When using the CONTROLLER without supplying cooling air, change setting parameter " **(P9)** Setting Air Input Monitoring Override " to **(00)** . When using the motor without supplying coolant air, pay attention to any temperature increases of the motor spindle.
- Do not make any sharp bends in the air hose, or pull on the hose as this can cause the hose to break, cut off the air supply or weaken the hose over time resulting in deterioration of the motor spindle.
- Never supply over regulated air pressure. There is a possibility to damage to the air detection sensor inside the CONTROLLER. If excessive air pressure is supplied, Warning code " A5 " will be displayed on the Digital Speed Indicator ⑬ and a warning signal (WARNING) will be output.
- The air detect function within the CONTROLLER detects air input supply only. If any problem such as damage to the air hose connected to the Air Output Joint ⑧ occurs, the air pressure will not be supplied to the motor and thus the air pressure will be undetectable.

15. OPERATION PROCEDURES

15 - 1 Button and LED Features of the Control Panel

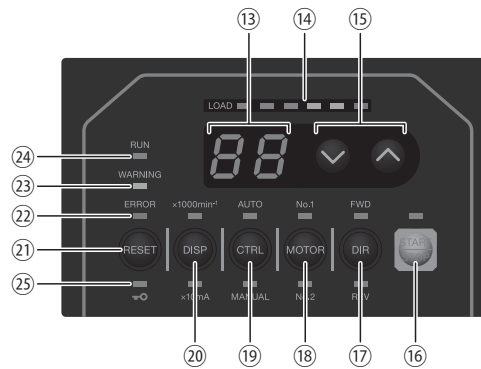

Fig. 19

This Operation Manual indicates the LED status as shown below.

















: LED lights













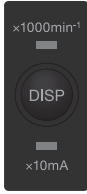
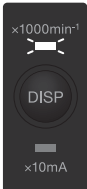
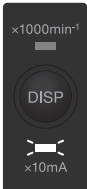

: LED blinks









Table. 3

Button / LED	Description	
Digital Speed Indicator ⑬ 	Preset Speed, Actual Speed, Warning and Error Codes are displayed in 2 digits format. When the motor spindle is stopped, the Preset Speed is displayed. When the motor spindle is rotating, the actual speed is displayed.	
Load Monitor (LOAD) ⑭ 	3 or less green LEDs are lit.	Continuous operation is possible.
	Any of the yellow or red LEDs are lit.	The Warning LED (Warning) will blink, if this condition is continued beyond the allowable interval the Error LED (Error) will light and the motor spindle will be shut down.
Motor Speed Adjustment Button (SPEED ▼, ▲) ⑮ 	Adjust the motor rotation speed. Each time the SPEED ▼ or ▲ button is pushed, the motor rotating speed increases or decreases by 1,000min ⁻¹ .	
	DOWN Button 	Push this button to decrease the motor rotating speed.
UP Button 	Push this button to increase the motor rotating speed.	

Button / LED	Description	
<p data-bbox="124 190 359 257">Start / Stop Button (START / STOP) ⑯</p> 	<p data-bbox="497 190 742 257">START / STOP LED goes out (not lit)</p> 	<p data-bbox="845 190 1236 224">The motor spindle is not rotating.</p>
	<p data-bbox="497 414 813 448">START / STOP LED lights</p> 	<p data-bbox="845 414 1468 448">The motor spindle is rotating at the specified speed.</p>
<p data-bbox="124 593 422 660">Rotation Direction Button (DIR) ⑰</p> 	<p data-bbox="497 593 1404 627">Select the right (FWD.) or left (REV.) rotation direction for the motor spindle.</p>	
	<p data-bbox="497 683 774 716">FWD LED (FWD) lights</p> 	<p data-bbox="845 683 1452 784">The motor spindle executes FWD. rotation. With the cutting tool facing the operator, right hand rotation (FWD.) will be counterclockwise rotation.</p>
<p data-bbox="497 952 766 985">REV LED (REV) lights</p> 	<p data-bbox="845 952 1436 1052">The motor spindle executes REV. rotation. With the cutting tool facing the operator, left hand rotation (REV.) will be clockwise rotation.</p>	
<p data-bbox="124 1220 406 1288">Motor Spindle Selection (MOTOR) Button ⑱</p> 	<p data-bbox="497 1220 1181 1254">Select the motor spindle (No. 1 or No. 2) to be controlled.</p>	
	<p data-bbox="497 1310 782 1344">No. 1 LED (No. 1) lights</p> 	<p data-bbox="845 1310 1372 1377">Select the motor spindle connected to Motor Connector No. 1 ⑵ .</p>
<p data-bbox="497 1579 782 1612">No. 2 LED (No. 2) lights</p> 	<p data-bbox="845 1579 1372 1646">Select the motor spindle connected to Motor Connector No. 2 ⑶ .</p>	

Button / LED	Description	
	Switch the control mode to MANUAL or AUTO.	
	MANUAL LED (MANUAL) lights 	Controlled by Control Panel ② .
	AUTO LED (AUTO) lights 	Controlled by input signal to Input / Output Connector A ③ from External Signal Source.
	Select the Motor Speed Indication or Motor Current Indication.	
	× 1000min ⁻¹ LED (1000min ⁻¹) lights 	Motor Speed Indication.
	× 10mA LED (× 10mA) lights 	Motor Current Indication. This display allows you to confirm the load/clamping level when fixing the Motor Spindle in fixed metal base. Adjust the clamping pressure level using the motor current display. Run the motor spindle at any speed and note the current level while the motor spindle is not secured in any manner. Insert the motor spindle into the fixture and carefully and slowly tighten. The Clamped Current Display should never be more than +1 (+10mA) of the current load reading before clamping. This is a very important step when installing the motor spindle. When the motor current is higher than 990mA,  will be displayed on the Digital Speed Indicator ⑬ .

Button / LED	Description	
Error Reset Button (RESET) ²¹ 	This switch resets and allows restarting of the motor spindle after an error has been corrected. To reset when an error occurs, 1. Remove or correct the cause of the error. Check P94 " 17 - 3 Resetting System after Error Codes Table. 9 ". Error will not be reset until the cause of the error has been removed. 2. Push the Error Reset Button (RESET). <div style="border: 1px solid black; padding: 5px; margin-top: 10px;"> <p>⚠ CAUTION</p> <p>If Error Signal cannot be reset by pushing the Error Reset Button (RESET) ²¹, there is a possibility that the CONTROLLER has been damaged.</p> <p>Please contact your local dealer.</p> </div>	
Error LED (ERROR) ²² 	Error LED (ERROR) goes out (not lit) 	When a serious problem with the system occurs, an alarm is emitted and this LED illuminates. Normal
Warning LED (WARNING) ²³ 	Warning LED (WARNING) goes out (not lit) 	When a serious problem with the system occurs, an alarm is emitted and this LED illuminates. Normal
Rotating LED (RUN) ²⁴ 	Rotating LED (RUN) goes out (not lit) 	The operating and working conditions of the system are constantly monitored and the Warning LED flashes. Normal
Rotating LED (RUN) ²⁴ 	Rotating LED (RUN) lights 	A problem has occurred. Emergency stop of the motor spindle has occurred. The Error code is displayed on the Digital Speed Indicator ¹³ . (Refer to P94 " 17 - 3 Resetting System after Error Codes Table. 9 ") A problem has occurred. The Warning code is displayed on the Digital Speed Indicator ¹³ . (Refer to P93 " 17 - 1 WARNING FUNCTION Table. 8 ") When the motor is rotating controlled by a seizing signal, this LED lights. The motor spindle has stopped. The motor spindle is controlled by a seizing signal.

Button / LED	Description
KEY HOLD LED () Button ⑳	A Key Hold Function is equipped to prevent erroneous operation by touching the control panel. All button operations will be disabled.
 	KEY HOLD LED () goes out (not lit) All button operations are enabled. To disable button operations on the Control Panel ② • Press and hold the Error Reset Button (RESET) ㉑ for 3 seconds when the KEY HOLD LED () ㉒ is not lit.
	KEY HOLD LED () lights Key Hold is enabled. All button operations are disabled. If any button is pressed, a warning beep will be emitted. To enable button operations on the Control Panel ② • Press and hold the Error Reset Button (RESET) ㉑ for 3 seconds when the KEY HOLD LED () ㉒ is lit.

15 - 2 Select Control Mode (MANUAL / AUTO). (Select the Control Button (CTRL) ⑱ of the Fig. 20.)

- (1) Using the Control Button (CTRL) ⑱, you can switch the operation mode for starting / stopping the Motor, setting rotation direction, motor speed and the like.

MANUAL Mode : Controlled by Control Panel ② .

AUTO Mode : Controlled by input signal to Input / Output Connector A ③ from External Signal Source.

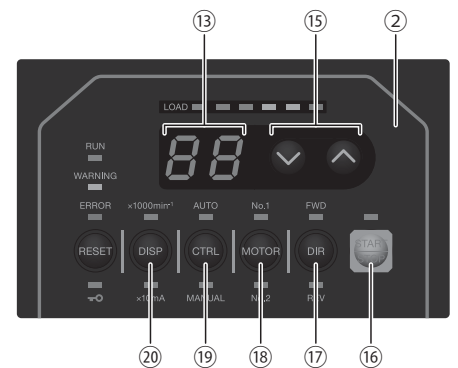

Fig. 20

15 - 3 Setting Motor Rotating Direction, Motor Spindle Selection Motor Start / Stop, Motor Speed

15 - 3 - 1 Manual Mode Operation

- (1) Setting Motor Rotating Direction

Set Motor Rotating Direction (Set the Rotation Direction Button (DIR) ⑱ of the Fig. 20.)

Push the Rotation Direction Button (DIR) ⑱ .

Select FWD. : Clockwise rotation

Select REV. : Counterclockwise rotation

With the cutting tool facing the operator right hand rotation (FWD.) will be clockwise rotation.

- (2) Motor Selection

Select the motor spindle to be controlled. (Motor Spindle Selection (MOTOR) Button ⑱ of the Fig. 20.) If motor spindle No. 1 was selected, No. 1 LED turns on. If motor spindle No. 2 was selected, No. 2 LED turns on.

- (3) Motor Start / Stop (Motor Start / Stop by pushing the START / STOP Button (START / STOP) ⑱ of the Fig. 20.)

The motor spindle will start and the LED will illuminate.

Push START / STOP Button (START / STOP) ⑱ again and the motor spindle will stop and the LED will go out.



(4) Setting Motor Speed

Setting Motor Speed (Set the Motor Speed Adjustment Button (SPEED  , ) ⑮ of the Fig. 20.)

Set the speed by pushing the Motor Speed Adjustment Button (SPEED  , ) ⑮ .

- Motor Speed Range is 1,000 - 50,000min⁻¹ (rpm).

- The motor speed is displayed in 1,000min⁻¹ (rpm) increments. 50 equals 50,000min⁻¹ (rpm).

To select 0.5 (500min⁻¹ (rpm)), push the Motor Speed Adjustment Button (SPEED  , ) ⑮ . When controlling motor speed from 1,000min⁻¹ (rpm) to 500min⁻¹ (rpm) or from 500min⁻¹ (rpm) to 1,000min⁻¹ (rpm), stop the motor spindle prior to changing speed.

CAUTION

Motor Speed limits depend on the Motor Model. Before using it, make sure to refer to P65 " 7. SYSTEM CHART " section, Fig. 3 and Fig. 4 and set the Motor Speed. Excessive speed will cause damage to the motor spindle.

15 - 3 - 2 Setting Auto Mode

Use the Input / Output Connector A ③ to input control signals to the CONTROLLER. (Except setting gear ratio)

(1) Set motor Rotating Direction

Input the " Rotating Direction Setting (Pin No. 2 : DIR_IN) "

Clockwise rotation is ' OFF (Open) ' (" FWD " , LED will illuminate)

Counterclockwise rotation is ' ON (Closed) ' (" REV " , LED will illuminate)

With the cutting tool facing the operator right hand rotation (FWD.) will be clockwise rotation.

(2) Motor Selection

Select the motor to be used with the motor select signal (Pin No. 15 : MT_SEL).

OFF (Open) : Motor No. 1

ON (Closed) : Motor No. 2

No. 1 LED (Motor No. 1) or No. 2 LED (Motor No. 2) lights and indicates the motor being used.



(3) Motor Start / Stop

Input the " Rotate Command (Pin No. 14 : START) "

Motor rotating is ' ON (Closed) '. When startup, START/STOP LED ⑮ of on the Control Panel ② will blink and motor will rotate.

(4) Setting the Motor Speed

- Motor Speed Range is 1,000 - 50,000min⁻¹ (rpm). Maximum motor speed depends on motor spindle model.

Setting parameter $\overline{P2}$ to ON allows the motor speed to be adjusted in Auto Mode using the Motor Speed Adjustment Button (SPEED  , ) ⑮ of the Fig. 23.

(Refer to P104 " 18 - 4 ② $\overline{P2}$ Setting AUTO Mode for Motor Speed Control " section.)

Rotational speed can be set by the using one of the following 3 methods.

① Setting by Analog signal

Input the " Motor Speed Control Voltage (Pin No. 23 : VR1) ". Refer to P86 " 16 - 1 (3) ④ Motor Speed Control Signal " section.

Set parameter \overline{PR} (Refer to P108 " 18 - 4 ⑩ \overline{PR} Selection of Motor Speed Control Voltage / DC+10V Signal Method " section), when you want to use the same speed command characteristic as the previous model E2530 CONTROLLER.

② Setting by Pulse Signal

(Set parameter $\overline{P7}$ of the CONTROLLER. (Refer to P106 " 18 - 4 ⑦ $\overline{P7}$ Selection of External Speed Control Mode " section.))

Input the " Count Pulse Signal for Setting Motor Speed (Pin No. 5 : CNT_IN) " and " UP / DOWN Signal for Setting Motor Speed (Pin No. 17 : UD_IN) " .

One pulse will increase or decrease 1,000min⁻¹ (rpm) in Spindle Speed. Counted on the leading edge of the signal.

" UP / DOWN Signal for Setting Motor Speed (Pin No. 17 : UD_IN) " is ' ON (Close) ' : increases speed, ' OFF (Open) ' : decreases speed.

③ Set by the Speed Point Signal

(Set parameter $\overline{P7}$. (Refer to P106 " 18 - 4 ⑦ $\overline{P7}$ Selection of External Speed Control Mode " section.))

Select the 4 Speed Points set beforehand by combination of " Speed Point Select 0 (POINT 0) (Pin No. 17 : SEL0) " and " Speed Point Select 1 (POINT 1) (Pin No. 5 : SEL1) " .

When selecting the Speed Point ($\overline{11}$ - $\overline{14}$), turn the " Motor Select (Pin No. 15 : MT_SEL) " to " OFF (Closed) " .

Table. 4 Combining Speed Point Select 0 (POINT 0) (Pin No. 17 : SEL0) with Speed Point Select 1 (POINT 1) (Pin No. 5 : SEL1) for Motor No. 1

Speed Point	SEL1(Pin No. 5)	SEL0 (Pin No. 17)
$\overline{11}$	OFF (Open)	OFF (Open)
$\overline{12}$	OFF (Open)	ON (Closed)
$\overline{13}$	ON (Closed)	OFF (Open)
$\overline{14}$	ON (Closed)	ON (Closed)

When selecting the Speed Point ($\overline{21}$ - $\overline{24}$) of Motor No. 2, turn the " Motor Select (Pin No. 15 : MT_SEL) " to ' ON (Closed) ' .

Table. 5 Combining Speed Point Select 0 (POINT 0) (Pin No. 17 : SEL0) with " Speed Point Select 1 (POINT 1) (Pin No. 5 : SEL1) " for Motor No. 2

Speed Point	SEL1 (Pin No. 5)	SEL0 (Pin No. 17)
$\overline{21}$	OFF (Open)	OFF (Open)
$\overline{22}$	OFF (Open)	ON (Closed)
$\overline{23}$	ON (Closed)	OFF (Open)
$\overline{24}$	ON (Closed)	ON (Closed)

(5) Resetting System after Error Codes

Releasing Error Code by The " Error Release (Pin No. 4 : RESET) " . Switch the signal on " Error Release (Pin No. 4 : RESET) " of Input / Output Connector A ③ ' OFF (Open) ' → ' ON (Closed) ' → ' OFF (Open) ' .

Error Signal will not be released until cause of the error has been removed.

Refer to P94 " 17 - 3 Resetting System after Error Codes " section.

16. EXTERNAL INPUT / OUTPUT CONNECTOR

16 - 1 External Input / Output Connector A ③

(1) Details of External Input / Output Connector A ③ Signals

⚠ WARNING

- **DO NOT** connect any circuit other than SELV (DC+24V) (Safety Extra Low Voltage) to the External Input / Output Connector A ③ of the CONTROLLER. This will cause I / O board damage in the CONTROLLER.
- Do not supply over voltage or over current into the input / output circuit. Always install a LOAD (resistor) to the output circuit to eliminate the chance of damage to the CONTROLLER.

⚠ CAUTION

Input / Output Connector A ③ do not use Pin No. 22. If pin No. 22 is connected, the CONTROLLER will be damaged.

Table. 6

Pin No.	Code	Function	Input / Output	Description
1	COM_1	External Power source for External input	Input	DC0V or DC+24V Power source to be used for External Inputs Signals.
2	DIR_IN	Rotating Direction Setting	Input	' OFF (Open) ' : FWD. ' ON (Closed) ' : REV. Controls the rotational direction of the motor spindle. Setting parameter \overline{PB} , can start with reverse rotation. (Refer to P107 " 18 - 4 ⑧ \overline{PB} Selection of External Motor Start Signal Control Mode " section.)
3	VR2	Motor No. 2 Speed Control Voltage	Input	Set rotating speed ($\times 10,000\text{min}^{-1}$) = $\frac{1}{16} \times (9\text{VR}-1)$ 0.28V or less : 1,000 min^{-1} 9V or more : 50,000 min^{-1} $0\text{V} \leq \text{VR} \leq 10\text{V}$ Sets rotating speed of Motor No. 2. When using 30,000 min^{-1} (rpm) motor speed, set parameter \overline{PR} (Refer to P108 " 18 - 4 ⑩ \overline{PR} Selection of Motor Speed Control Voltage / DC+10V Signal Method "). Refer to P87 Fig. 27, 28 regarding relationship between Motor Speed and Motor Speed Control Voltage (VR).
4	RESET	Error Release	Input	' ON (Closed) ' → ' OFF (Open) ' Error Code can be released and the system restarted by toggling this signal OFF and ON. Error will not be released until cause of the error has been removed.

Pin No.	Code	Function	Input / Output	Description	
5	SEL1	Count Pulse Signal for Setting Motor Speed (CNT_IN)	Input	—	One pulse will increase or decrease 1,000min ⁻¹ in Spindle Speed depending on parameter $\text{P}7$ setting. (Refer to P106 " 18 - 4 ⑦ $\text{P}7$ Selection of External Speed Control Mode " section.)
		Speed Point Select 1 (POINT 1)			Speed Point Signal can be selected. Speed Point (When using Motor No. 1, " 11 " - " 14 ", and when using Motor No. 2, " 21 " - " 24 ") can be selected by POINT 0 and POINT 1 signal combination. Refer to P79 " 15 - 3 - 2 (4) ③ Set by the Speed Point Signal " section. Need to set parameter $\text{P}7$. (Refer to P106 " 18 - 4 ⑦ $\text{P}7$ Selection of External Speed Control Mode " section.)
6	RUN	Rotating	Output	' OFF (Open) ' : Stop ' ON (Closed) ' : Rotating	Output shows that the motor is rotating.
7	DIR_OUT	Rotating Direction	Output	' OFF (Open) ' : FWD. ' ON (Closed) ' : REV.	Output shows the direction of the Motor is rotating.
8	ERR	Error	Output	' OFF (Open) ' : Error ' ON (Closed) ' : Normal	Output shows that error has occurred. Error code will be displayed on Control Panel ② . When setting parameter $\text{P}1$, Error Output Mode can be changed. (Refer to P104 " 18 - 4 ① $\text{P}1$ Setting of Error Output Mode " section.)
9	SEL_MT	Motor Select	Output	'OFF (Open)' : MOTOR1 'ON (Closed)' : MOTOR2	Output shows that the selected motor is MOTOR No. 1 or MOTOR No. 2.
10	GND	Internal GND for Motor Speed Control Voltage	Output	Internal CONTROLLER GND	This GND will be used for " Motor Speed Control Voltage (VR) " .
11	Vcc	Internal Power Source for Motor Speed Control Voltage	Output	Internal Power Source : DC+10V	Internal Power Source for " Motor Speed Control Voltage (VR) " .
12	MOTOR_I	Motor Current Monitor	Output	2Amp / V, $0V \leq \text{MOTOR_I} \leq 10V$	Output Motor Current Monitor with Analog Monitor Voltage. 2Amp / 1V. Max. 20Amp.
13	GND	Internal GND for Analog Monitor	Output	Internal CONTROLLER GND	This GND will be used for analog monitor (MOTOR_I, SPEED_V, and LOAD).

Pin No.	Code	Function	Input / Output	Description
14	START	Rotate Command	Input	' OFF (Open) ' : Stop ' ON (Closed) ' : Start Motor Start and Motor Stop Signal Setting parameter (P8), can start with forward rotation. (Refer to P107 " 18 - 4 ⑧ (P8) Selection of External Motor Start Signal Control Mode " section.)
15	MT_SEL	Motor Select	Input	' OFF (Open) ' : MOTOR1 ' ON (Closed) ' : MOTOR2 Select MOTOR No. 1 or MOTOR No. 2.
16	500min ⁻¹ (rpm)	Rotates Motor at " Centering " speed	Input	' ON (Closed) ' : 500min ⁻¹ (rpm) Set motor rotation speed will be 500min ⁻¹ (rpm). Use the Centering Mode.
17	SEL0	UP / DOWN Signal for Setting Motor Speed (UD_IN)	Input	— Determines speed up or speed down. Need to set parameter (P7). (Refer to P106 " 18 - 4 ⑦ (P7) Selection of External Speed Control Mode " section.)
		Speed Point Select 0 (POINT 0)		
18	COM_2	External Power Source for External Output	Input	DC0V or DC+24V Power source to be used for External outputs Signals.
19	PULSE	Rotating Pulse	Output	1 pulse / rotation 1 revolution of the motor generates one pulse. Duty 50%.
20	WARNING	WARNING	Output	OFF (Open) : Normal Operation ON (Closed) : Warning Output shows that warning has occurred. Warning code will be displayed on Control Panel ② .
21	COIN	Speed Achievement	Output	OFF (Open) : Set speed not achieved ON (Closed) : Set speed achieved Shows that the Motor has achieved more than 90% of the set speed.
22	Not used	—	—	— *Note : Never use a pin labeled not used.

Pin No.	Code	Function	Input / Output	Description	
23	VR1	Motor No. 1 Speed Control Voltage	Input	Set rotating speed ($\times 10,000\text{min}^{-1}$) = $\frac{1}{16} \times (9\text{VR}-1)$ 0.28V or less : $1,000\text{min}^{-1}$ 9V or more : $50,000\text{min}^{-1}$ $0\text{V} \leq \text{VR} \leq 10\text{V}$	Sets rotating speed of the motor. When using $30,000\text{min}^{-1}$ of motor speed, setting parameter PR (Refer to P108 " 18 - 4 PR Selection of Motor Speed Control Voltage / DC+10V Signal Method " section.) Refer to P87 Fig. 27, 28 about relationship between motor speed and control signal.
24	LOAD	Torque Load Monitor	Output	Torque Load Monitor (%) = Torque Load Monitor Voltage $\times 20$	Shows that the torque being applied to the analog motor. $20\% / \text{V } 100\% \text{ (rating) / DC+5V}$ Torque Load Monitor : 0 - 200% $(0\text{V} \leq \text{LOAD} \leq 10\text{V})$
25	SPEED_V	Rotating Speed Analog Monitor Voltage	Output	$10,000\text{min}^{-1} \text{ (rpm) / V}$	Output the rotation speed of rotating motor with Analog Monitor Voltage. $10,000\text{min}^{-1} \text{ (rpm) / V}$ $0\text{V} \leq \text{SPEED_V} \leq 10\text{V}$

(2) Input / Output Diagram

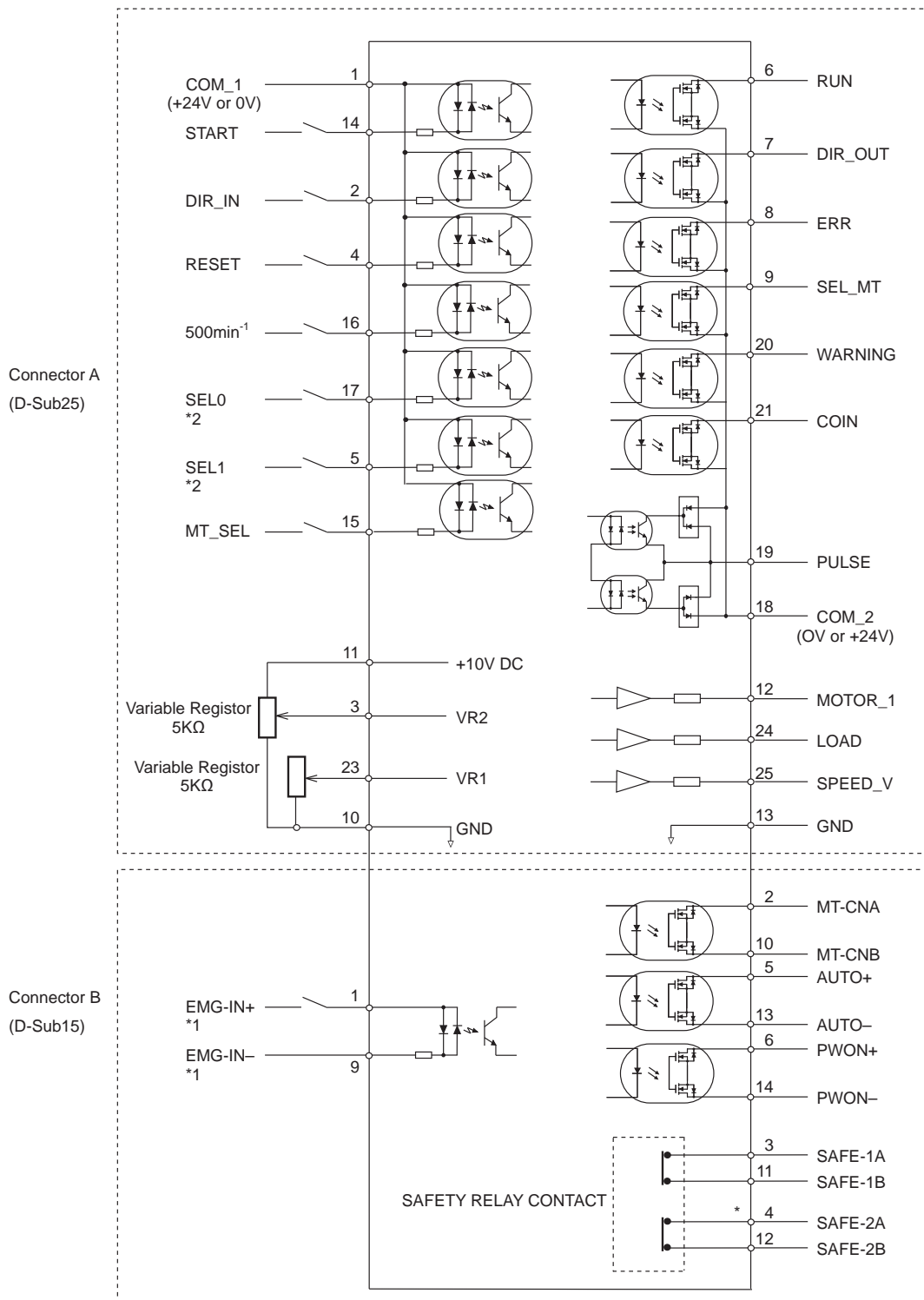

Fig. 21

*1 When using the "EMG - IN" Signal, set parameter Pb . (Refer to P108 "18 - 4 ⑩ Pb Selection of Emergency Stop Function" sectional.)

*2 When using SEL 0 as the UP / DOWN Signal for Setting Motor Speed (UD_IN) and SEL 1 as Count Pulse Signal for Setting Motor Speed (CNT_IN), set parameter $P7$. (Refer to P106 "18 - 4 ⑦ $P7$ Selection of External Speed Control Mode").

(3) Input / Output Signal

① Input Signal

There are 7 different input signals : " Rotate Command (START) ", " Rotating Direction Setting (DIR_IN) ", " Rotates Motor at " Centering " speed (500min⁻¹ (rpm)) ", " Error Release (RESET) ", " Speed Point Select 0 (POINT 0) ", " Speed Point Select 1 (POINT 1) " and " Motor Select (MT_SEL) ". These signals are DC+24V signals from an external signal source. Please use a separate power source that is capable of supplying DC+24V ± 10%, 100mA. Refer to Fig. 22 for connections.

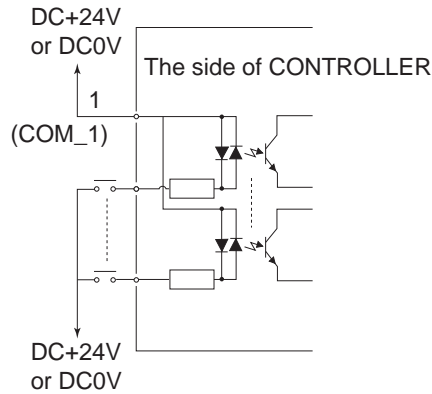

Fig. 22

② Output Signal I

There are 6 separate output signals : " Rotating (RUN) ", " Rotating Direction (DIR_OUT) ", " Error (ERR) ", " WARNING (WARNING) ", " Speed Achievement (COIN) " and " Motor Select (SEL_MT) ". These signals are MOSS Relay Contact Connections. The output current can be connected to either sinking or sourcing.

Voltage and Current Specifications

- Applied Voltage (V) ≤ DC+30V
- Working Current (I_p) ≤ 100mA

Use an external power source for output circuits. It is recommended to use the same DC+24V power source used for input signals. Please refer to Fig. 23 for connections.

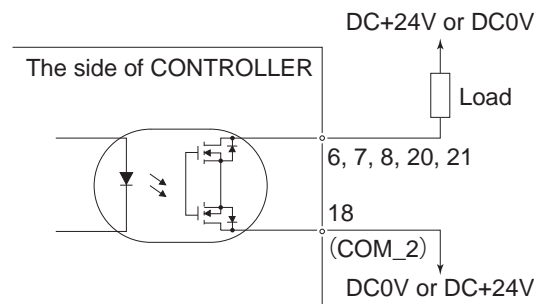

Fig. 23

③ Output Signal II

Refer to Fig. 24 regarding the Output Signal of the " Rotating Pulse (PULSE) ". The output signal can be connected for either sinking or sourcing.

Voltage and Current Specifications

- Applied Voltage (V) \leq DC+30V
- Working Current (Ip) \leq 50mA

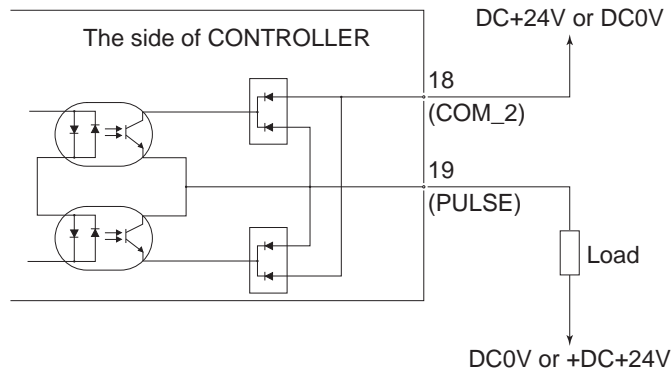

Fig. 24

④ Motor Speed Control Signal

Rotation Speed can be selected by, applying analog voltage to VR1 and VR2. Refer to Fig. 25, 26 for connections. Refer to Fig. 27, 28 for the relationship between Motor Speed and " Motor Speed Control Voltage (VR) ".

CAUTION

When applying the VR, never input more than DC+10V to the CONTROLLER (Fig. 26). This will cause serious damage to the I / O Board in the CONTROLLER.

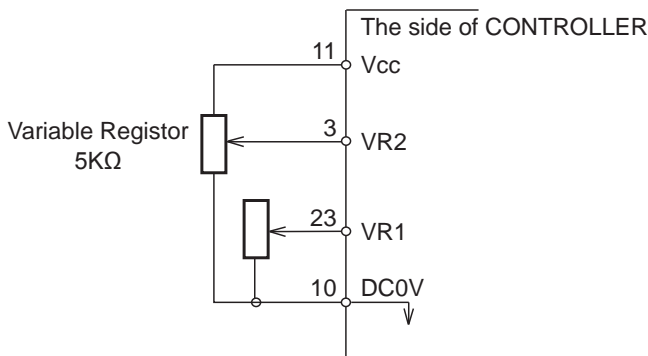

Fig. 25

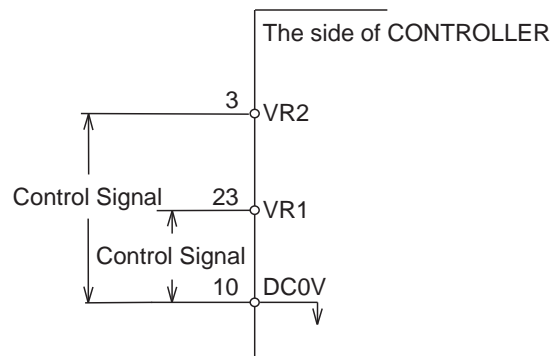

Fig. 26

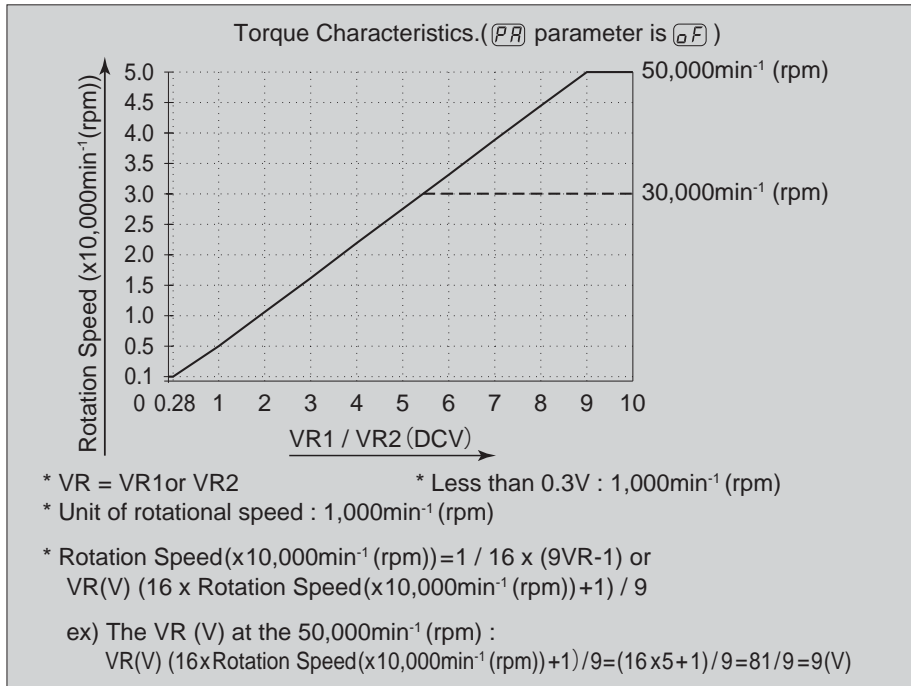

Fig. 27

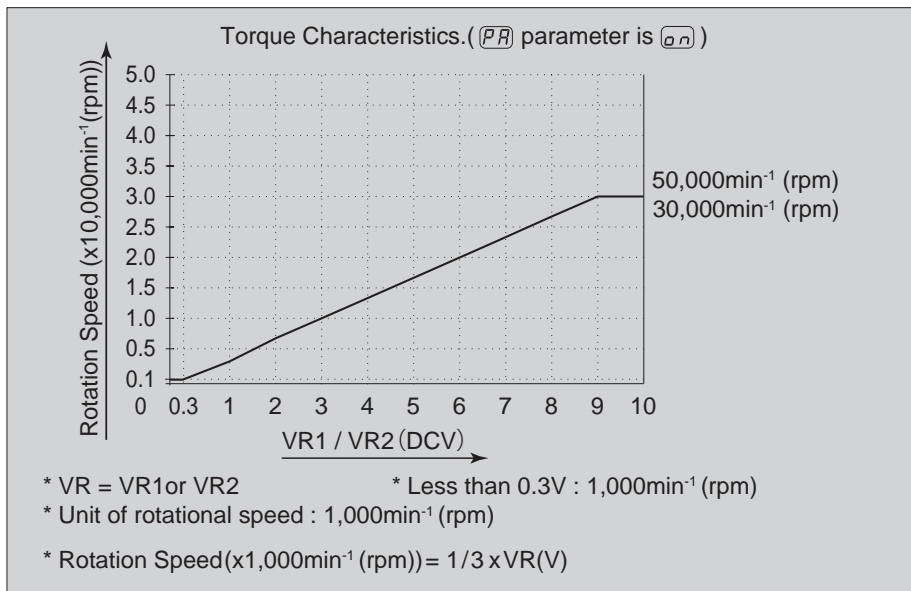

Fig. 28

⑤ Analog Monitor Signals

There are 3 types of monitoring signals : " Motor Current Monitor (MOTOR_I) ", " Torque Load Monitor (LOAD) ", and " Rotating Speed Analog Monitor Voltage (SPEED_V) ". Please refer to Fig. 29 for connections.

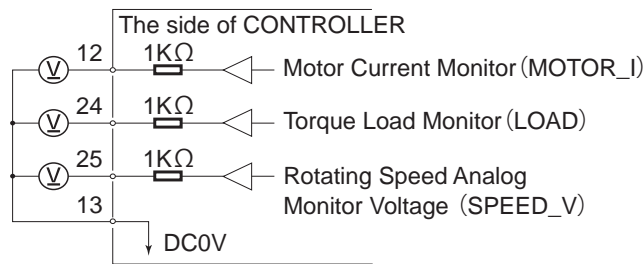

Fig. 29

16 - 2 External Input / Output Connector B ④

(1) Details of External Input / Output Connector B ④ Signals

⚠ WARNING

- **DO NOT** connect any circuit other than SELV (DC+24V) (Safety Extra Low Voltage) to the External Input / Output Connector B ④ of the CONTROLLER. This will cause I / O board damage in the CONTROLLER.
- Do not supply over voltage or over current into the input / output circuit. Always install a LOAD (resistor) to the output circuit to eliminate the chance of damage to the CONTROLLER.

⚠ CAUTION

Input / Output Connector B ④ DOES NOT use Pin No. 7, No. 8, and No. 15. If pin No. 7, No. 8, and No. 15 are connected, the CONTROLLER will be damage.

Table. 7

Pin No.	Code	Function	Input / Output	Description	
1	EMG-INA	Emergency Stop A	Input	External Power Source input for Emergency Stop Signal or Emergency Stop Signal ' OFF (Open) '	External Power Source input for Emergency Stop Signal or Emergency Stop Signal. Normal Operation ' ON (Closed) ', Emergency ' OFF (Open) '. When using the Emergency Stop Signal, set parameter (Pb). (Refer to P108 " 18 - 4 ① (Pb) Selection of Emergency Stop Function " section.)
2	MT-CNA	Motor Connect Contact A	Output	Continuity, ' OFF (Open) ', between Pin No. 2 and Pin No. 10 the motor is connected.	When there is continuity, OFF, between Pin No. 2 and Pin No. 10 and the selected motor is connected, if no continuity is present, the motor is disconnected or the motor cord is broken.
3	SAFE-1A	Safety Relay Contact 1A	Output	Pin No. 3 and Pin No. 11 continuity ' ON (Closed) ' Safety Relay is OFF	When there is continuity between Pin No. 3 and Pin No. 11 are ' ON (Closed) ' Safety Relay is OFF (System Stopped), no continuity Safety Relay is ' OFF (Open) ' Normal Operation.
4	SAFE-2A	Safety Relay Contact 2A	Output	Pin No. 4 and Pin No. 12 continuity ' ON (Closed) ' Safety Relay is OFF	When there is continuity between Pin No. 4 and Pin No. 12 are ' ON (Closed) ' Safety Relay is OFF (System Stopped), no continuity Safety Relay is ' OFF (Open) ' Normal Operation.
5	AUTO +	Control Mode AUTO Signal (+)	Output	Control Mode AUTO Pin No. 5 and Pin No. 13 are ' ON (Closed) '	When Control Mode AUTO is being used, this Pin No. 5 and Pin No. 13 are ' ON (Closed) '.
6	PWON +	CONTROLLER Power Source Monitor (+)	Output	Pin No. 6 and Pin No. 14 are ' ON (Closed) ' : Main Power Supply is connected '	If the Main Power Switch ⑨ is ON, Pin No. 6 and Pin No. 14 are ' ON (Closed) '.

Pin No.	Code	Function	Input / Output	Description	
7	Not Used	—	—	—	*Note : Never use pin labeled not used.
8	Not Used	—	—	—	*Note : Never use pin labeled not used.
9	EMG-INB	Emergency Stop B	Input	External Power Source input for Emergency Stop Signal or Emergency Stop Signal ' OFF (Open) '	External Power Source input for Emergency Stop Signal or Emergency Stop Signal. Normal Operation ' ON (Closed) ', Emergency ' OFF (Open) '. When using the Emergency Stop Signal, set parameter Pb . (Refer to P108 " 18 - 4 ⑩ Pb Selection of Emergency Stop Function " section.)
10	MT-CNB	Motor Connect Contact B	Output	Continuity, ' OFF (Open) ', between Pin No. 2 and Pin No. 10 the motor is connected.	When there is continuity, OFF, between Pin No. 2 and Pin No. 10 are ' OFF (Open) ', the selected motor is connected, if no continuity the motor is disconnected or the motor cord is broken.
11	SAFE-1B	Safety Relay Contact 1B	Output	Pin No. 3 and Pin No. 11 continuity ' ON (Closed) ' Safety Relay is OFF	When there is continuity between Pin No. 3 and Pin No. 11 are ' ON (Closed) ' Safety Relay is OFF (System Stopped), no continuity Safety Relay is ' OFF (Open) ' Normal Operation.
12	SAFE-2B	Safety Relay Contact 2B	Output	Pin No. 4 and Pin No. 12 continuity ' ON (Closed) ' Safety Relay is OFF	When there is continuity between Pin No. 4 and Pin No. 12 are ' ON (Closed) ' the Safety Relay is OFF (System Stopped). If there is no continuity, Safety Relay is ' OFF (Open) ' Normal Operation.
13	AUTO -	Control Mode AUTO Signal (-)	Output	Control Mode AUTO Pin No. 5 and Pin No. 13 are ' ON (Closed) '	When Control Mode AUTO is being used, this Pin No. 5 and Pin No. 13 are ' ON (Closed) '.
14	PWON -	CONTROLLER Power Source Monitor (-)	Output	Pin No. 6 and Pin No. 14 are ' ON (Closed) ' : Main Power Supply is connected	If the Main Power Switch ⑨ is ON, Pin No. 6 and Pin No. 14 are ' ON (Closed) '.
15	Not Used	—	—	—	*Note : Never use pin labeled not used.

(2) Input / Output Signals

① Output Signal

Pin No. 2 - 10, 5 - 13, 6 - 14

There are 3 different output signals : " Motor Connect Contact (MT-CN) ", " Control Mode AUTO Signal (AUTO) ", and " CONTROLLER Power Source Monitor (PWON) " .

These signals are MOSS Relay Contact Connections. The output current can be connected for either sinking or sourcing.

Voltage and Current Specifications

- Applied Voltage (V) \leq DC+30V
- Working Current (Ip) \leq 100mA

Use an external power source for output circuits. It is recommended to use a separate power supply Input / Output Connector B ④. Please refer to Fig. 30 for connections.

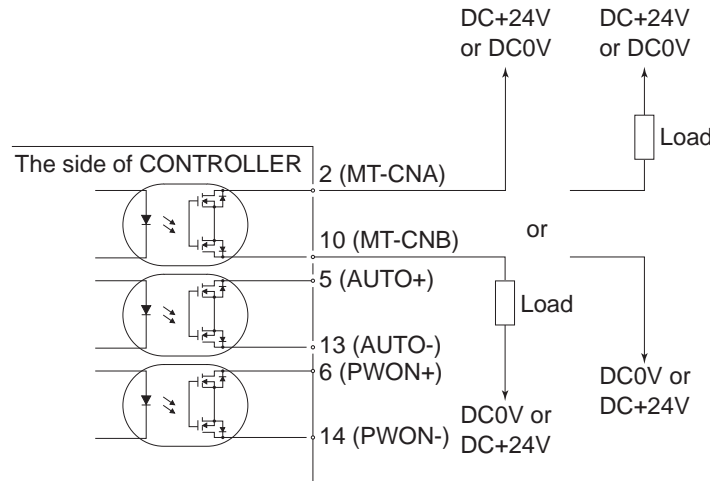

Fig. 30

② Emergency Stop Signal Input

Pin No. 1 - 9

This signal is a switched DC+24V output.

Please use a separate power source that is capable of applying DC+24V \pm 10%, 50mA. Refer to Fig. 31 below for connections.

Normal Operation circuit is ' ON (Closed) ' Emergency Stop circuit is ' OFF (Open) ' .

If the Emergency Stop Signal is ' OFF (Open) ' the Safety Relay is OFF and the power supply to the motor is interrupted and the motor stops.

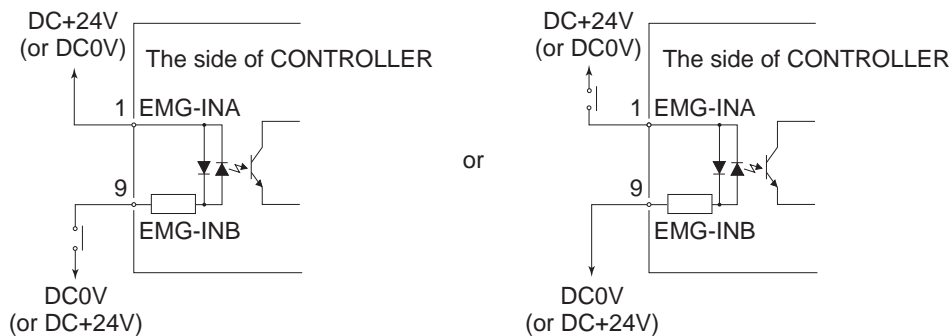

Fig. 31

③ Safety Relay Signal

CAUTION

If the Emergency Stop Function is not installed, the Emergency Stop Signal (EMG - IN) will not function. If enabling the Emergency Stop Function, it is necessary to set parameter **Pb** (Refer to P108 " 18 - 4 ⑪ **Pb** Selection of Emergency Stop Function " section.)

Pin No. 3 - 1 1, 4 - 1 2

- The Safety Relay will be ON or OFF depending on the state of the " Emergency Stop (Pin No. 1 : EMG - INA - Pin No. 9 : EMG - INB) ".
- When there is continuity between Pin No. 3 (SAFE - 1A) and Pin No. 11 (SAFE - 1B) or between Pin No. 4 (SAFE - 2A) and Pin No. 12 (SAFE - 2B) the motor is off. If there is no continuity between these pairs of pins then the system is operating normally.
- If the Emergency Stop Signal is ' OFF (Open) ' the Safety Relay will be ' OFF (Open) ' and the motor power will be interrupted and the motor will stop.
- If the (NO) Normally Open contacts of the Safety Relay are welded together by an over load or short circuit the (NC) Normally Closed contacts separation are maintained with more than 0.5mm spacing by the relay's recoil mechanism.
- The voltage / current specifications of Pin No. 3 - 11 and Pin No. 4 - 12.
 - Applied Voltage (V) \leq DC+30V
 - Working Current (Ip) \leq 2A

Refer to Fig. 32 below for connections.

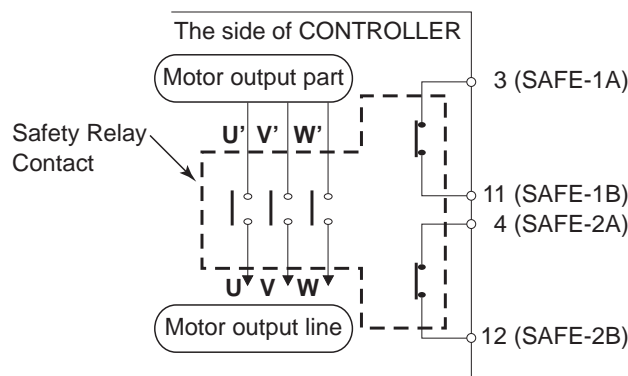

Fig. 32

* Safety Relay

If an N - O contact becomes welded, all N - C contacts will maintain a minimum distance of 0.5 mm when the coil is not energized.

N - O contacts (Normally - opened contacts) : Contacts of U - U', V - V', W - W'.

N - C contacts (Normally - closed contacts) : Contacts of (SAFE - 1A) - (SAFE - 1B), (SAFE - 2A) - (SAFE - 2B)

* Machine Safety Circuit is possible when using the Safety Relay Contacts Output

- When an Emergency Stop Signal input that is coupled to a door open switch of an Industrial Machine, the Safety Relay will energize and open the Motor Power Line circuit.
- Contact outputs ((SAFE - 1A) - (SAFE - 1B), (SAFE - 2A) - (SAFE - 2B)) of the N - C contacts can be used for detecting the opening of the Motor Power Line. If N - O contacts become welded, contact outputs will maintain an OFF (Open) condition, by Forced Guide Mechanism. Therefore, Safety Relay can be used as an open signal of a movable guard or operator door with a locking (switch) mechanism for Industrial Machinery.

16 - 3 External Input / Output Connector Specifications

⚠ CAUTION

- To minimize RF interference and noise, please keep the length of the cables as short as possible and route them separately or as far away as possible from high voltage electrical cables.
- Use only shielded cables to minimize RF interference and noise. Connect the shield to the plug cover.
- Connect the shielded line to the Input / Output connector (The shielded line is grounded). Do not connect another shielded line to any externally powered instrument.

① External Input / Output Connector A ③

Plug Part Number : XM3A - 2521 OMRON (or other similar high - quality product)

Cover Part Number : XM2S - 2511 OMRON (or other similar high - quality product)

② External Input / Output Connector B ④

Plug Part Number : XM3A - 1521 OMRON (or other similar high - quality product)

Cover Part Number : XM2S - 1511 OMRON (or other similar high - quality product)

Please prepare a Cover and Plug.

The shielding should be connected to the Cover.

* Use Mounting Screws that are (M2.6)

Fasten the Connector to the CONTROLLER using Mounting Screws (M2.6).

16 - 4 External Input / Output Connector A ③ / B ④ Pin configuration

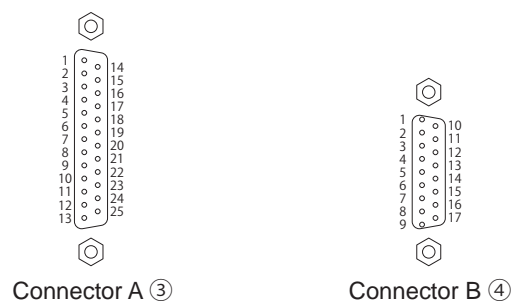

Fig. 33

17. PROTECT FUNCTION

17 - 1 WARNING FUNCTION

CAUTION

When the Warning LED (WARNING) ⑳ on the CONTROLLER blinks, conditions exist that could result in dangerous operation.
Check operating conditions and continue to use only after correcting the problem.

Always check the CONTROLLER, motor spindle and the condition of the cooling air prior to use. This will help prevent system errors that will result in non - operational conditions.

- (1) The WARNING LED (WARNING) ⑳ will blink.
- (2) The Warning Code (listed in Table. 8) will be displayed on the Digital Speed Indicator ⑬.
- (3) A Warning Signal is output to the " WARNING (PIN No. 20 : WARNING) " of Input / Output Connector.
In Warning state, the motor will not stop automatically.

Table. 8

Warning Code	Warning Function	Trouble
A0	Motor Cord	Motor Code is not connected. Damage of the Motor Cord or contact failure of the Connector occurs. If the motor is operated in this state, Error " E3 " will be displayed.
A1	Low Air Pressure	Low Air Pressure during motor rotation. If the air pressure remains low for 4 seconds, Error " E7 " will be displayed.
A2	CONTROLLER Overheat	CONTROLLER is Overheated. If the temperature increases further, Error " E4 " will be displayed.
A3	Over Load	Motor Torque Load exceeding safe limits. If the overload state continues, Error " E8 " will be displayed.
A4	Emergency Stop Signal	Emergency Stop Signal 'OFF (Open)' in Emergency Stop Mode Condition. If the motor is operated in this state, Error " EE " will be displayed.
A5	Over Air Pressure	Excessive Air Pressure. The motor will not stop.

CAUTION

When the Warning LED (WARNING) ⑳ blinks while the control is in Mode AUTO, be sure to confirm the Warning Code displayed on the Digital Speed Indicator ⑬ by referring to the " Warning Code " in Table. 8.

17 - 2 Detection of unsafe operating conditions

Always check the CONTROLLER, motor spindle and the condition of the cooling air prior to operation. This will help prevent system errors that will result in improper operating conditions.

When an Error Occurs, the following events may occur :

- (1) Motor stops.
- (2) The Error LED (ERROR) ㉔ will light.
- (3) The Error Code in Table. 9 will displayed on Digital Speed Indicator ⑬ .
- (4) The illumination of the CONTROLLER will blink (Refer to P103 " 18 - 3 ⑫  Selection of Illumination Brightness Fig. 36, 37 ").
- (5) An Error signal is output to the " Error (PIN No. 8 : ERR) " of Input / Output Connector A ③ .

* Setting parameter **P1**, will Change the Error Output Mode of the Error Signal. (Refer to P104 " 18 - 4 ① **P1** Setting of Error Output Mode " section.)

* Error history can be checked with parameter "**PE**". (Refer to P110 " 18 - 4 ⑭ **PE** Error History ".)

17 - 3 Resetting System after Error Codes

There are 2 methods of releasing Error Code.

(1) When the control is in MANUAL Mode :

Push the Error Reset Button (RESET) ⑳ on the Control Panel ㉑ .

(2) When the control is in AUTO Mode :

Toggle the signal on " Error Release (Pin No. 4 : RESET) " of Input / Output Connector A ㉓ ' OFF (Open) ' → ' ON (Closed) ' → ' OFF (Open) '.

* When releasing Error using the " Rotate Command (Pin No. 14 : START) " is ' ON (Closed) ', ' OFF (Open) ' Motor Start / Stop before resuming operation.

Table. 9

Error Code	Problem Area	Trouble
E1	Excess Current	Motor Current beyond safe limits.
E2	Over Voltage	Motor Voltage beyond safe limits.
E3	Motor Sensor Malfunction, Motor Cord Disconnect	The sensor signal has malfunctioned or Motor Cord Connector is not connected.
E4	CONTROLLER overheat	CONTROLLER overheat.
E5	Brake Circuit Trouble	Trouble with the Brake Circuit.
E6	Rotor Lock	Motor Stalled for more than 3 seconds.
E7	Low Air Pressure	Inadequate air pressure is supplied for more than 4 seconds during rotation or inadequate air pressure is supplied when a motor start commanded.
E8	Torque Over Load	Torque limits are exceeded for too long a period of time. (Refer to P95 " 17 - 4 Torque Over Load ".)
E9	Communication Interception	Intercept communication with SELECTOR. (Only if using CONTROLLER connect to SELECTOR.)
EA	External Control Signal Error	<ul style="list-style-type: none"> • When Control Mode is in AUTO, the Control Command Signal is ' ON (Closed) ' before Main Power Switch ㉑ is turned ON. • When Control Mode is AUTO, the ERROR command is released without stopping the Control Command Signal ' OFF (Open) '.
EL	Incompatible Motor	An unrecognizable motor is connected to the CONTROLLER.
EH	Over Speed	Rotating Speed is beyond the motors capability.
EE	Emergency Stop Error	Activated when Emergency Stop Signal is ' OFF (Open) ', or when rotating, Emergency Stop occurred by Emergency Stop Signal ' OFF (Open) '.
EC	Internal Memory Error	Internal Memory Problem (EEPROM).

CAUTION

- When the Warning LED blinks while the control is in Mode AUTO, be sure to confirm the Warning Code displayed on the Digital Speed Indicator ⑬ by referring to the " Warning Code " in Table. 8.
- When an error occurs due to internal damage of the CONTROLLER, the Error Signal cannot be reset. Please send the Motor spindle and CONTROLLER to a NAKANISHI dealer for repair.

17 - 4 Torque Over Load

CAUTION

If you constantly operate the system in an overload condition, even for short periods of time, the CONTROLLER will overheat and damage to the CONTROLLER and motor spindle are possible. NAKANISHI recommends only continuous duty operation (LOAD LEDs with 3 LEDs lit) : Torque Load Monitor (LOAD) Voltage should be less than 5V.

When the Load Monitor LED (LOAD) ⑭ lights 4 or more LEDs (3 Green LEDs and 1 or more yellow LEDs) an overload condition exists. During a motor overload period, the following will occur :

- (1) Warning LED (WARNING) ⑲ will blink.
- (2) Warning Code " A3 " is displayed on the Digital Speed Indicator ⑬ .
- (3) Pin No. 20 (WARNING) of the External Input / Output Connector A ③ is ' ON (Closed) ' .



Overload operation is considered a short-term operation mode. The allowable operation time depends on the number of lighted LEDs on the Load Monitor LED (LOAD) ⑭.

The allowable time is detailed below.

- (1) Load Monitor LED (LOAD) ⑭ 4 LEDs (Green LED 3, Yellow LED 1) : 30 Seconds
- (2) Load Monitor LED (LOAD) ⑭ 5 LEDs (Green 3, Yellow 2) : 10 Seconds
- (3) Load Monitor LED (LOAD) ⑭ 6 LEDs (Green 3, Yellow 2, Red 1) : 5 Seconds

When the allowable time is exceeded the motor will stop and the following occurs :

- (1) Control Button (CTRL) ⑲ lights.
- (2) Error Code " E8 " is displayed on the Digital Speed Indicator ⑬ .
- (3) Pin No. 8 (ERR) of the External Input / Output Connector A ③ is ' ON (Closed) ' .

* Setting parameter  Error Signal, allows the signal to be a Normally Open or Normally Closed State (Refer to P104 " 18 - 4 ①  Setting of Error Output Mode " section).

18. SETTING OF OPERATING PARAMETERS

18 - 1 Entering Parameter Setting Mode

CAUTION

When in the parameter mode, normal operation of starting, stopping, etc. operation is not possible. When changing from the parameter mode to normal operation, be sure to toggle the Main Power Switch ⑨ OFF and ON again.

- (1) Make sure that the Main Power Switch ⑨ is turned OFF.
- (2) While pushing and holding the Error Reset Button (RESET) ⑳ while turning the Main Power Switch ⑨ ON at the front of the CONTROLLER.
- (3) Hold the Error Reset Button (RESET) ⑳ down for 3 seconds while the CONTROL is powering up.
- (4) The buzzer will 'BEEP' 3 times, then release the Error Reset Button (RESET) ⑳ and Parameter Setting Mode will start. $P1$ is Displayed.

18 - 2 Parameter Types

Parameter types, contents, and default are detail in Table. 10.

When checking a parameter or changing a setting, refer to P104 " 18 - 4 Setting procedures " section.

Table. 10

Code	Types	Contents	Default
$P1$	Setting of Error Output Mode	Changes the Error Output Signal, when an error occurs from normally open to normally closed.	OF
$P2$	Setting AUTO Mode for Motor Speed Control	When the control is in AUTO mode, the speed control is adjustable from the Control Panel ② of the CONTROLLER, set the parameter to ON to adjust the speed in AUTO Mode.	OF
$P3$	Setting Fixed Motor No. 1 Speed	When Fixed Motor Speed is desired, set the parameter to ON . * Settable Motor Speed range is 1,000 - 50,000min ⁻¹ in 1,000min ⁻¹ increments. * When the Motor Rotation Speed set in parameter $P3$ is higher than the Motor Rotation Speed set in parameter $P5$, the actual motor rotation speed will be the rotational speed that was set in the parameter $P5$.	OF
$P4$	Setting Fixed Motor No. 2 Speed	When Fixed Motor Speed is desired, set the parameter to ON . * Settable Motor Speed range is 1,000 - 50,000min ⁻¹ in 1,000min ⁻¹ increments. * When the Motor Rotation Speed set in parameter $P4$ is higher than the Motor Rotation Speed set in parameter $P6$, the actual motor rotation speed will be the rotational speed that was set in the parameter $P6$.	OF

Code	Types	Contents	Default
P5	Setting Maximum Motor No. 1 Speed	When Maximum Motor Speed is desired, set the parameter to 0n and set the maximum speed. * Settable Motor Speed Range is 1,000 - 50,000min ⁻¹ in 1,000min ⁻¹ increments.	0F
P6	Setting Maximum Motor No. 2 Speed	When Maximum Motor Speed is desired, set the parameter to 0n and set the maximum speed. * Settable Motor Speed Range is 1,000 - 50,000min ⁻¹ in 1,000min ⁻¹ increments.	0F
P7	Selection of External Speed Control Mode	The following Rotation Speed options can be selected when control mode is AUTO. Rn : Analog Signal cn : Pulse Signal Pd : Speed Point Signal * When Rn is selected, use External Input/Output Connector A ③ Pin No. 23 (VR1), No. 3 (VR2). * When cn or Pd is selected, use External Input/Output Connector A ③ Pin No. 17 (SEL0), No. 5 (SEL1).	Rn
P8	Selection of External Motor Start Signal Control Mode	When control mode is in AUTO, please set the parameter to 0n and set the desired rotating direction of the motor. Activate Pin 2 to set a reverse direction along with the start command. * Clockwise rotation (FWD) + START/STOP ...External Input/Output Connector A Pin No. 14 (START) * Counterclockwise rotation (REV) + START/STOP ...External Input/Output Connector A Pin No. 2 (DIR_IN)	0F
P9	Selection of Air Input Monitoring Override	If you want to start the motor without supplying cooling air, please set the parameter to 0n . (When set this parameter, motor speed will be limited to 30,000min ⁻¹ (rpm).)	0F
PA	Selection of Motor Speed Control Voltage / DC+10V Signal Method	When using the Motor Speed Control Voltage Signal and a 30,000min ⁻¹ motor, in AUTO Mode, set the parameter to 0n . When using the 50,000min ⁻¹ motor, set the parameter to 0F .	0F
Pb	Selection of Emergency Stop Function	When using the Emergency Stop Selection Mode, please set the parameter to 0n . When the parameter is set to 0n , use External Input/Output Connector B ④ Pin No. 1 (EMG - INA) and No. 9 (EMG - INB).	0F
Pc	Selection of Illumination Brightness	Select the brightness of the blue illumination on the Control Panel ② and the bottom of CONTROLLER.	1E or 2E
Pd	Confirmation of Parameter Setting	Contents of the parameters that are set can be confirmed. (P1 - Pc .) (No parameter setting is necessary).	
PE	Error History	Error code history of the last 5 error events can be confirmed. (No parameter setting is necessary).	--
Pn	Confirmation of Software Version	Shows the Software Version number of the CONTROLLER.	

18 - 3 Contents of Parameters

CAUTION



The operating parameters can be preset depending on the application requirements. Please operate only after confirming contents of parameter settings.

The following parameters can be set.

① Setting of Error Output Mode

- Selection of the error output mode is on " Error (Pin No. 8 : ERR) " of Input / Output Connector A ③.
- When an error occurs the output can be select to ' ON (Closed) ' or ' OFF (Open) '.
- Signals can be output according to the required machine control logic of the system.

Table. 11

Parameter 	Set Contents
	Error Occurred : Signal is ' OFF (Open) '.
	Error Occurred : Signal is ' ON (Closed) '.

② Setting AUTO Mode for Motor Speed Control









- Allows the setting of the manner in which Motor speed can be controlled when the system is being used in the Controls' AUTO MODE (External Command Signal Control).
- This parameter selects between speed control with the Motor Speed Adjustment Button (SPEED  , ) ⑮ of the Control Panel ② or by External Command Signal through Input / Output Connector A ③.

Table. 12

Parameter 	Set Contents
	Set the Motor Rotation Speed by External Command Signal through External Input / Output Connector A ③ .
	Set the Motor Rotation Speed by Motor Speed Adjustment Button (SPEED  , ) ⑮ via the Control Panel ② .



③ Setting Fixed Motor No. 1 Speed

CAUTION

If you set the rotation speed higher than the rotation speed set at  , rotation speed will be set according to  .

- Allows the Motor No. 1 speed to be fixed. Settable Motor Speed Range is 1,000 - 50,000min⁻¹ in 1,000min⁻¹ increments.
- Proactively prevents inadvertent change in speed.
- The Fixed Motor Speed can set by Control Mode MANUAL or AUTO.

Table. 13

Parameter 	Set Contents
	Fixed Motor Speed for Motor No. 1 is disabled.
	Fixed Motor Speed for Motor No. 1 is enabled.

④ **P4** Setting Fixed Motor No. 2 Speed

CAUTION

If you set the rotation speed higher than the rotation speed set at **P6**, rotation speed will be set according to **P6**.

- Allows the Motor No. 2 speed to be fixed. Settable Motor Speed Range is 1,000 - 50,000min⁻¹ in 1,000min⁻¹ increments.
- Proactively prevents inadvertent change in speed.
- The Fixed Motor Speed can set by Control Mode MANUAL or AUTO.

Table. 14

Parameter P4	Set Contents
oF	Fixed Motor Speed for Motor No. 2 is disabled.
on	Fixed Motor Speed for Motor No. 2 is enabled.

⑤ **P5** Setting Maximum Motor No. 1 Speed

- Maximum Motor No. 1 Speed can be set.
 - * Settable Motor Speed Range is 1,000 - 50,000min⁻¹ in 1,000min⁻¹ increments.
- Allows a safe maximum rotational speed limit depending on the application.
- The Maximum Motor Speed can set by Control Mode MANUAL or AUTO.

Table. 15

Parameter P5	Set Contents
oF	Setting of Maximum Motor Speed for Motor No. 1 is disabled.
on	Setting of Maximum Motor Speed for Motor No. 1 is enabled.

⑥ **P6** Setting Maximum Motor No. 2 Speed

- Maximum Motor No. 2 Speed can be set.
 - * Settable Motor Speed Range is 1,000 - 50,000min⁻¹ in 1,000min⁻¹ increments.
- Allows a safe maximum rotational speed limit depending on the application.
- The Maximum Motor Speed can set by Control Mode MANUAL or AUTO.

Table. 16

Parameter P6	Set Contents
oF	Setting of Maximum Motor Speed for Motor No. 2 is disabled.
on	Setting of Maximum Motor Speed for Motor No. 2 is enabled.

⑦ **P7** Selection of External Speed Control Mode

- When Control Mode is in AUTO, it is possible to select the External Speed Control Mode from Analog Signal **Rn**, Pulse Signal **Cn**, or Speed Point Signal Parameter **Pd**.

Table. 17

Parameter P7	Set Contents
Rn	Set speed by Analog Signal.
Cn	Set speed by Pulse Signal.
Pd	Set speed by Speed Point Signal.

- When setting by Analog Signal **Rn**, use the External Input / Output Signal " Motor Speed Control Voltage (Pin No. 23 : VR1, Pin No. 3: VR2)". Motor No. 1 uses (Pin No. 23 : VR1), and Motor No. 2 uses (Pin No. 3 : VR2).
- When setting via the Pulse Signal **Cn**, use the UP / DOWN Signal for Setting Motor Speed (Pin No. 17 : SEL0 (UD_IN)) and Count Pulse Signal for Setting Motor Speed (Pin No. 5 : SEL1 (CNT_IN)). The motor speed change per pulse is 1000min⁻¹ (rpm).
External Input / Output Signal " UP / DOWN Signal for Setting Motor Speed (Pin No. 5 : UD_IN)" is as follows :
OFF (Open) : Rotation speed decreases
ON (Closed) : Rotation speed increases
Even if the Motor is switched to the other one, the previous motor speed setting will be affected.
The motor speed settings of Motor No. 1 and No. 2 are stored after turned the power off.
The pulse-train signal of the maximum frequency is 100msec.
- When setting by Speed Point Signal **Pd**, select Motor number to be set by Motor Select Signal (Pin No. 15 : MT_SEL) firstly. Then select the Speed Point by using the combination of " Speed Point Select 0 (Pin No. 17 : SEL0 (POINT 0))" and " Speed Point Select 1 (Pin No. 5 : SEL1 (POINT 1))".
Motor No. 1 and No. 2 can be set in 4 different Speed Point (rotating speed).

When selecting the Speed Point (**11** - **14**), turn the Motor Select (Pin No. 15 : MT_SEL) to " OFF (Open)". Then select the Speed Point (**11** - **14**) by using the combination of " Speed Point Select 0 (Pin No. 17 : SEL0 (POINT 0))" and " Speed Point Select 1 (Pin No. 5 : SEL1 (POINT 1))".

Table. 18 Motor No. 1 Selection of the Speed Point. Combination of " Speed Point Select 0 (Pin No. 17 : SEL0 (POINT 0))" and " Speed Point Select 1 (Pin No. 5 : SEL1 (POINT 1))".

Speed Point	SEL1 (Pin No. 5)	SEL0 (Pin No. 17)
11	OFF (Open)	OFF (Open)
12	OFF (Open)	ON (Closed)
13	ON (Closed)	OFF (Open)
14	ON (Closed)	ON (Closed)

When selecting the Speed Point (**21** - **24**), turn the Motor Select (Pin No. 15 : MT_SEL) to " ON (Closed)". Then select the Speed Point (**21** - **24**) by using the combination of " Speed Point Select 0 (Pin No. 17 : SEL0 (POINT 0))" and " Speed Point Select 1 (Pin No. 5 : SEL1 (POINT 1))".

Table. 19 Motor No. 2 Selection of the Speed Point. Combination of " Speed Point Select 0 (Pin No. 17 : SEL0 (POINT 0)) " and " Speed Point Select 1 (Pin No. 5 : SEL1 (POINT 1)) " .

Speed Point	SEL1 (Pin No. 5)	SEL0 (Pin No. 17)
21	OFF (Open)	OFF (Open)
22	OFF (Open)	ON (Closed)
23	ON (Closed)	OFF (Open)
24	ON (Closed)	ON (Closed)

- Can setting the different rotation speed in The Speed Points.
Speed ranges from 1,000 - 50,000min⁻¹ (rpm) can be set.

⑧ **P8** Selection of External Motor Start Signal Control Mode

- The settings of the rotating direction and starting up motor can be done at the same time.
- When in Auto Control Mode, the Motor Start Signal can be used for either forward or reverse direction by commanding a Direction Signal and a Start Signal. When set, the rotation direction is controlled by " Rotating Direction Setting (Pin No. 2 : DIR_IN) ", ' OFF (Open) ' : FWD, ' ON (Closed) ' : REV and the Start Signal is controlled by " Rotate Command (Pin No. 14 : START) " .

Table. 20

Parameter P8	Set Contents
0F	Motor startup and rotating direction is not commanded by signal.
0n	The startup motor with FWD. rotation or the startup motor with REV. rotation.

⑨ **P9** Selection of Air Input Monitoring Override

When **P9** is set to **0n** , the motor can rotate without air pressure detection.

⚠ CAUTION

- When using the motor spindle without supplying cooling air as recommended, do not spray coolant directly on the motor spindle.
- Motor start is possible without supplying cooling air, however maximum motor speed is limit to 30,000min⁻¹ (rpm). Pay attention to any temperature increases of the motor.

Table. 21

Parameter P9	Set Contents
0F	Air pressure is supplied.
0n	Air pressure is not supplied.

CAUTION

Set the Motor Speed Control Voltage so that it does not exceed the maximum rotation speed for the spindle in use.

- Set the parameter to (0n) when you want to use the same speed command characteristic as the previous model E2530 CONTROLLER.
- The Fig. 34 are Characteristics of the Motor Speed Control Voltage Signal and rotation speed by parameter (PR) set to (0F). The Fig. 35 are Characteristics of the Motor Speed Control Voltage Signal and rotation speed by parameter (PR) set to (0n).

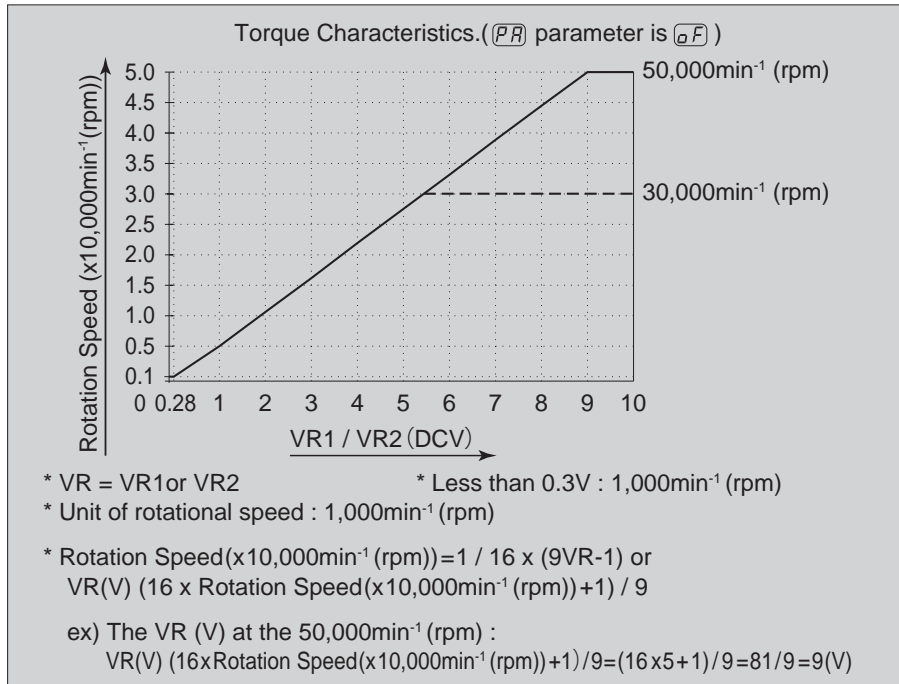

Fig. 34

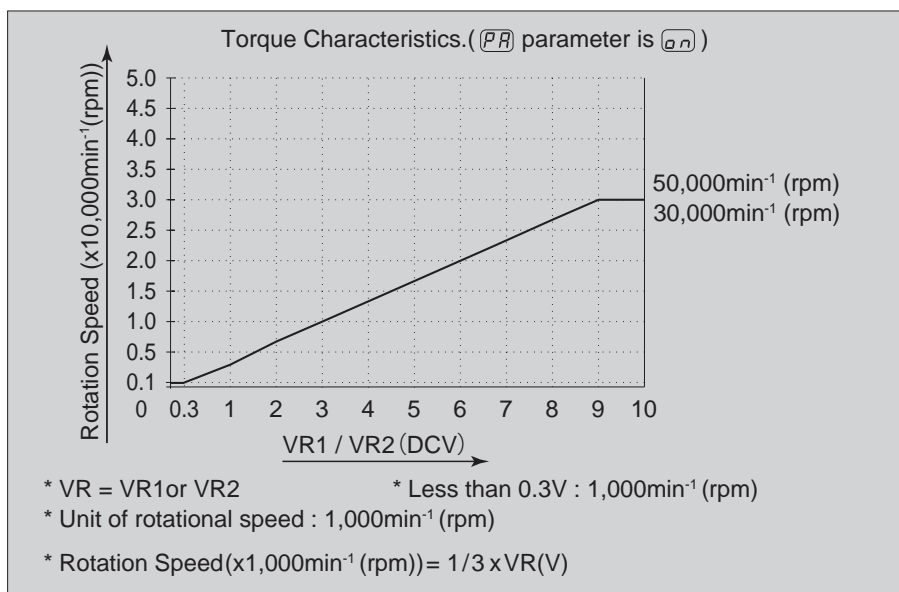

Fig. 35

Table. 22

Parameter (P_A)	Set Contents
$(0F)$	Maximum rotation speed : speed command characteristic of 50,000min ⁻¹
$(0n)$	The same speed command characteristic as the previous model E2530 CONTROLLER

⑪ (P_b) Selection of Emergency Stop Function

- The Emergency Stop Function can be enabled or disabled.
- When " Emergency Stop A (Pin No. 1 : EMG - INA) " and " Emergency Stop B (Pin No. 9 : EMG - INB) " of the External Input / Output Connector B ④'s input signal are set to ' OFF (Open) ', Safety Relay will activate and block the Motor Power Line and make an emergency stop.
Normally, " Emergency Stop A (Pin No. 1 : EMG - INA) " and " Emergency Stop B (Pin No. 9 : EMG - INB) " input signal need to be set to ' ON (Closed) '.
- Allows the establishment of a safe machine operating system by utilizing auxiliary contacts of Safety Relay (SAFE-1, SAFE-2).

Table. 23

Parameter (P_b)	Set Contents
$(0F)$	Emergency Stop Function is deactivated.
$(0n)$	Emergency Stop Function is activated.

⑫ (P_c) Selection of Illumination Brightness

Select the brightness of the blue illumination from 4 patterns.
The brightness can be configured separately for the Illumination on the front side of the CONTROLLER and the illumination on the bottom side of the CONTROLLER.



Outline of Control Panel

Fig. 36



Two guidelines

Fig. 37

Table. 24

Parameter (P_c)	Illumination Area	Brightness
$(1E)$	Control Panel Face	High
$(1e)$		Medium
$(1L)$		Low
(1)		Off
$(2E)$	Bottom of CONTROLLER	High
$(2e)$		Medium
$(2L)$		Low
(2)		Off

⑬ **Pd** Confirmation of Parameter Setting

- This mode allows the user to check the settings of parameters **P1** - **Pc** . The parameter **PE** and **Pn** cannot be checked.

⑭ **PE** Error History

- The Error History, which records previous error codes can be confirmed by the Error Code displayed on the Digital Speed Indicator ⑬.
- The last Error Code recorded will be **H1** and the oldest will be **H5** The Error code is displayed on the Digital Speed Indicator ⑬.
- The Error History cannot be erased or deleted.
- If Error History contains more than five errors, oldest Error History, **H5** will be deleted.
- To clear Error History, push and hold the START / STOP Button (START / STOP) ⑯ for three seconds. A beep emits and the Error History will be cleared.

⑮ **Pn** Confirmation of Software Version

- The version of the program installed on the CONTROLLER can be checked.
- The program version is displayed on the Digital Speed Indicator ⑬ .

18 - 4 Setting procedures

① **P1** Setting of Error Output Mode

⚠ CAUTION

If the Error Output Mode has been changed from the default setting, that setting will be displayed the next time you enter Parameter Setting Mode.

Procedure

1. Push the START / STOP Button (START / STOP) ⑯ .
2. **oF** is displayed. This indicates that when an error occurs, the output will be ' OFF (Open) ' .
3. Push the START / STOP Button (START / STOP) ⑯ .
4. **oN** is displayed. This indicates that when an error occurs, the output will be ' ON (Closed) ' .
5. You can cycle through the choices by pushing the START / STOP Button (START / STOP) ⑯ .
6. Push the Error Reset Button (RESET) ⑳ to send the settings to memory. **≡≡** followed by **P1** will be displayed.
7. If you desire to set other parameters, push the Motor Speed Adjustment Button (SPEED **▼** , **▲**) ⑮ to select the parameter that needs to be set.
8. When you are finished setting parameters, turn the Main Power Switch ⑨ to OFF.

② **P2** Setting AUTO Mode for Motor Speed Control

Procedure















1. Push the START / STOP Button (START / STOP) ⑯ .
2. **oF** is displayed. This indicates that speed control by the Motor Speed Adjustment Button (SPEED **▼** , **▲**) ⑮ is disabled (The External Command Signal Control will be operational).
3. Push the START / STOP Button (START / STOP) ⑯ .
4. **oN** is displayed. This indicates that speed control is changeable by the Motor Speed Adjustment Button (SPEED **▼** , **▲**) ⑮ .
5. You can cycle through the choices by pushing the START / STOP Button (START / STOP) ⑯ .
6. Push the Error Reset Button (RESET) ⑳ to send the settings to memory. **≡≡** followed by **P2** will be displayed.
7. If you desire to set other parameters, push the Motor Speed Adjustment Button (SPEED **▼** , **▲**) ⑮ to select the parameter that needs to be set.
8. When you are finished setting parameters, turn the Main Power Switch ⑨ to OFF.

③ Setting Fixed Motor No. 1 Speed

CAUTION















Actual motor rotation speed of the motor will be limited, based on maximum motor rotation speed and the type of motor connected.

Procedure

1. Push the START / STOP Button (START / STOP) .
2.  is displayed. This indicates that Fixed Motor Rotation Speed cannot be set.
3. Push the START / STOP Button (START / STOP) .
4. The setting Motor Rotation Speed displayed on Digital Speed Indicator .
5. Push the Motor Speed Adjustment Button (SPEED  , )  to set the motor rotation speed.
The Motor Rotation Speed range is 1,000 - 50,000min⁻¹ (rpm).
6. Push the Error Reset Button (RESET)  to send the settings to memory.  followed by  will be displayed.
7. If you desire to set other parameters, push the Motor Speed Adjustment Button (SPEED  , )  to select the parameter that needs to be set.
8. When you are finished setting parameters, turn the Main Power Switch  to OFF.

④ Setting Fixed Motor No. 2 Speed

Procedure















1. Push the START / STOP Button (START / STOP) .
2.  is displayed. This indicates that Fixed Motor Rotation Speed cannot be set.
3. Push the START / STOP Button (START / STOP) .
4. The setting Motor Rotation Speed displayed on Digital Speed Indicator .
5. Push the Motor Speed Adjustment Button (SPEED  , )  to set the motor rotation speed.
The Motor Rotation Speed range is 1,000 - 50,000min⁻¹ (rpm).
6. Push the Error Reset Button (RESET)  to send the settings to memory.  followed by  will be displayed.
7. If you desire to set other parameters, push the Motor Speed Adjustment Button (SPEED  , )  to select the parameter that needs to be set.
8. When you are finished setting parameters, turn the Main Power Switch  to OFF.

⑤ Setting Maximum Motor No. 1 Speed

CAUTION





Actual motor rotation speed of the motor will be limited, based on maximum motor rotation speed and the type of motor connected.

Procedure

1. Push the START / STOP Button (START / STOP) .
2.  is displayed. This indicates that Maximum Motor Rotation Speed cannot be set.
The Maximum Motor Rotation Speed is 50,000min⁻¹ (rpm).
3. Push the START / STOP Button (START / STOP) .
4. The Maximum Motor Rotation Speed is displayed on Digital Speed Indicator .
5. Push the Motor Speed Adjustment Button (SPEED  , )  to set the motor rotation speed.
The Motor Rotation Speed range is 1,000 - 50,000min⁻¹ (rpm).
6. Push the Error Reset Button (RESET)  to send the settings to memory.  followed by  will be displayed.
7. If you desire to set other parameters, push the Motor Speed Adjustment Button (SPEED  , )  to select the parameter that needs to be set.
8. When you are finished setting parameters, turn the Main Power Switch  to OFF.





















⑥ **P6** Setting Maximum Motor No. 2 Speed















Procedure

1. Push the START / STOP Button (START / STOP) ⑯ .
2. **OF** is displayed. This indicates that Maximum Motor Rotation Speed cannot be set.
The Maximum Motor Rotation Speed is 50,000min⁻¹ (rpm).
3. Push the START / STOP Button (START / STOP) ⑯ .
4. The Maximum Motor Rotation Speed is displayed on Digital Speed Indicator ⑬ .
5. Push the Motor Speed Adjustment Button (SPEED  , ) ⑮ to set the motor rotation speed.
The Motor Rotation Speed range is 1,000 - 50,000min⁻¹ (rpm).
6. Push the Error Reset Button (RESET) ⑳ to send the settings to memory. **EE** followed by **P6** will be displayed.
7. If you desire to set other parameters, push the Motor Speed Adjustment Button (SPEED  , ) ⑮ to select the parameter that needs to be set.
8. When you are finished setting parameters, turn the Main Power Switch ⑨ to OFF.

⑦ **P7** Selection of External Speed Control Mode

Procedure



1. Push the START / STOP Button (START / STOP) ⑯ .
2. **Rn** will be displayed. The motor speed can be set by using analog signal.
Push the Motor Speed Adjustment Button (SPEED  , ) ⑮ .
cn will be displayed. The motor speed can be set by using pulse signal.
Push the Motor Speed Adjustment Button (SPEED  , ) ⑮ .
PO will be displayed. The motor speed can be set by using speed point signal.
3. Set each signal following the procedure below.
 - 3-1. To set **Rn** :
Push the Motor Speed Adjustment Button (SPEED  , ) ⑮ . While **Rn** is displayed, push the Error Reset Button (RESET) ⑳ .
After the setting is saved, **EE** will be displayed followed by **P7** .
To set other parameters, push the Motor Speed Adjustment Button (SPEED  , ) ⑮ .
To finish setting parameters, turn the Main Power Switch ⑨ OFF.
 - 3-2. To set **cn** :
Push the Motor Speed Adjustment Button (SPEED  , ) ⑮ . While **cn** is displayed, push the Error Reset Button (RESET) ⑳ .
After the setting is saved, **EE** will be displayed followed by **P7** .
To set other parameters, push the Motor Speed Adjustment Button (SPEED  , ) ⑮ .
To finish setting parameters, turn the Main Power Switch ⑨ OFF.
 - 3-3. To set **PO** :
Push the Motor Speed Adjustment Button (SPEED  , ) ⑮ . While **PO** is displayed, push the START / STOP Button (START / STOP) ⑯ .
 - 3-3-1. **11** and **1** will be displayed alternately. The Speed Point " 1 " (Motor No. 1) can be set.
Push the Motor Speed Adjustment Button (SPEED  , ) ⑮ to set motor rotation speed.
 - 3-3-2. To set the Speed Point " 2 " (Motor No. 1), push the START / STOP Button (START / STOP) ⑯ .
12 and **1** will be displayed alternately. The Speed Point " 2 " (Motor No. 1) can be set.
Push the Motor Speed Adjustment Button (SPEED  , ) ⑮ to set motor rotation speed.
 - 3-3-3. To set the Speed Point " 3 " (Motor No. 1), push the START / STOP Button (START / STOP) ⑯ .
13 and **1** will be displayed alternately. The Speed Point " 3 " (Motor No. 1) can be set.
Push the Motor Speed Adjustment Button (SPEED  , ) ⑮ to set motor rotation speed.

- 3-3-4. To set the Speed Point " 4 " (Motor No. 1), push the START / STOP Button (START / STOP) ^⑮ .
 (14) and (1) will be displayed alternately. The Speed Point " 4 " (Motor No. 1) can be set.
 Push the Motor Speed Adjustment Button (SPEED  , ) ^⑮ to set motor rotation speed.
- 3-3-5. To set the Speed Point " 1 " (Motor No. 2), push the START / STOP Button (START / STOP) ^⑮ .
 (21) and (1) will be displayed alternately. The Speed Point " 1 " (Motor No. 2) can be set.
 Push the Motor Speed Adjustment Button (SPEED  , ) ^⑮ to set motor rotation speed.
- 3-3-6. To set the Speed Point " 2 " (Motor No. 2), push the START / STOP Button (START / STOP) ^⑮ .
 (22) and (1) will be displayed alternately. The Speed Point " 2 " (Motor No. 2) can be set.
 Push the Motor Speed Adjustment Button (SPEED  , ) ^⑮ to set motor rotation speed.
- 3-3-7. To set the Speed Point " 3 " (Motor No. 2), push the START / STOP Button (START / STOP) ^⑮ .
 (23) and (1) will be displayed alternately. The Speed Point " 3 " (Motor No. 2) can be set.
 Push the Motor Speed Adjustment Button (SPEED  , ) ^⑮ to set motor rotation speed.
- 3-3-8. To set the Speed Point " 4 " (Motor No. 2), push the START / STOP Button (START / STOP) ^⑮ .
 (24) and (1) will be displayed alternately. The Speed Point " 4 " (Motor No. 2) can be set.
 Push the Motor Speed Adjustment Button (SPEED  , ) ^⑮ to set motor rotation speed.
- 3-3-9. To set the Speed Point " 1 " (Motor No. 1), push the START / STOP Button (START / STOP) ^⑮ .
- 3-3-10. To finalize the settings, push the Error Reset Button (RESET) ^⑳ .
 After the settings have been finalized, (P0) will be displayed.
4. To return to the (Rn) or (cn) setting, push the Motor Speed Adjustment Button (SPEED  , ) ^⑮ and go to step 3-1 or 3-2.
 5. To finish the settings, push the Error Reset Button (RESET) ^⑳ .
 6. After the settings are saved, (E-) will be displayed followed by (Pn) .
 7. To set other parameters, push the Motor Speed Adjustment Button (SPEED  , ) ^⑮ .
 8. To finish setting parameters, turn the Main Power Switch ^⑨ OFF.

⑧ (PB) Selection of External Motor Start Signal Control Mode







Procedure

1. Push the START / STOP Button (START / STOP) ^⑮ .
2. (0F) is displayed. This indicates that motor startup and setting the rotation direction cannot be performed simultaneously.
3. Push the START / STOP Button (START / STOP) ^⑮ .
4. (0n) is displayed. This setting is clockwise rotation with motor startup by " Rotation Command (Pin No. 14 : START) " or left hand rotation with motor startup by " Rotating Direction Setting (Pin No. 2 : DIR_IN) " can be set.
5. You can cycle through the choices by pushing the START / STOP Button (START / STOP) ^⑮ .
6. Push the Error Reset Button (RESET) ^⑳ to send the settings to memory. (E-) followed by (PB) will be displayed.

7. If you desire to set other parameters, push the Motor Speed Adjustment Button (SPEED  , ) ⑮ to select the parameter that needs to be set.
8. When you are finished setting parameters, turn the Main Power Switch ⑨ to OFF.







⑨ Selection of Air input Monitoring Override

Procedure

1. Push the START / STOP Button (START / STOP) ⑮ .
2.  is displayed. This indicates that supplying cooling air into the motor spindle and motor speed will perform normally at start - up.
3. Push the START / STOP Button (START / STOP) ⑮ .
4.  is displayed. This indicates that without supplying cooling air, motor startup is possible with limited speed.
5. You can cycle through the choices by pushing the START / STOP Button (START / STOP) ⑮ .
6. Push the Error Reset Button (RESET) ⑳ to send the settings to memory.  followed by  will be displayed.
7. If you desire to set other parameters, push the Motor Speed Adjustment Button (SPEED  , ) ⑮ to select the parameter that needs to be set.
8. When you are finished setting parameters, turn the Main Power Switch ⑨ to OFF.







⑩ Selection of Motor Speed Control Voltage / DC+10V Signal Method

Procedure

1. Push the START / STOP Button (START / STOP) ⑮ .
2.  is displayed. The rotating speed can be set in range of 10,000 - 50,000min⁻¹ (rpm).
3. Push the START / STOP Button (START / STOP) ⑮ .
4.  is displayed. The rotating speed can be set in range of 10,000 - 30,000min⁻¹ (rpm).
5. You can cycle through the choices by pushing the START / STOP Button (START / STOP) ⑮ .
6. Push the Error Reset Button (RESET) ⑳ to send the settings to memory.  followed by  will be displayed.
7. If you desire to set other parameters, push the Motor Speed Adjustment Button (SPEED  , ) ⑮ to select the parameter that needs to be set.
8. When you are finished setting parameters, turn the Main Power Switch ⑨ to OFF.





⑪ Selection of Emergency Stop Function

Procedure

1. Push the START / STOP Button (START / STOP) ⑮ .
2.  is displayed. This indicates that Emergency Stop Function cannot be used.
3. Push the START / STOP Button (START / STOP) ⑮ .
4.  is displayed. This indicates that Emergency Stop Function is active.
5. You can cycle through the choices by pushing the START / STOP Button (START / STOP) ⑮ .
6. Push the Error Reset Button (RESET) ⑳ to send the settings to memory.  followed by  will be displayed.
7. If you desire to set other parameters, push the Motor Speed Adjustment Button (SPEED  , ) ⑮ to select the parameter that needs to be set.
8. When you are finished setting parameters, turn the Main Power Switch ⑨ to OFF.

⑫ **Pc** Selection of Illumination Brightness

Procedure

1. Push the START / STOP Button (START / STOP) ⑮ .
2. The first digit shows **1** and indicates the position of the blue illumination on the Control Panel, and the second digit shows the brightness level. For details on brightness level, refer to P103 " Table. 24 " .
3. Push the Motor Speed Adjustment Button (SPEED  , ) ⑮ .
The brightness level changes alternately as follow: **13** ⇔ **12** ⇔ **11** ⇔ **10**
4. To select the brightness of the illumination on the bottom of the case, push the START / STOP Button (START / STOP) ⑮ .
5. The first digit shows **2** and indicates the position of the blue illumination on the bottom, and the second digit shows the brightness level. For details on brightness level, refer to P103 " Table. 24 " .
6. Push the Motor Speed Adjustment Button (SPEED  , ) ⑮ .
The brightness level changes alternately as follow: **23** ⇔ **22** ⇔ **21** ⇔ **20**
7. Push the Error Reset Button (RESET) ⑳ to send the settings to memory. **33** followed by **Pc** will be displayed.













⑬ **Pd** Confirmation of Parameter Setting

Procedure



1. Push the START / STOP Button (START / STOP) ⑮ .
2. The setting of the **P1** (**oF** or **oN**) and **P1** are displayed.
3. Push the Motor Speed Adjustment Button (SPEED  , ) ⑮ .
4. The setting of the **P2** (**oF** or **oN**) and **P2** are displayed.
5. Push the Motor Speed Adjustment Button (SPEED  , ) ⑮ .
6. The setting of the **P3** (**oF** or **oN**) and **P3** are displayed.
When motor rotation speed is 30,000min⁻¹ (rpm), " 30 " is displayed.
7. Push the Motor Speed Adjustment Button (SPEED  , ) ⑮ .
8. The setting of the **P4** (**oF** or **oN**) and **P4** are displayed.
9. Push the Motor Speed Adjustment Button (SPEED  , ) ⑮ .
10. The setting of the **P5** (**oF** or **oN**) and **P5** are displayed.
11. Push the Motor Speed Adjustment Button (SPEED  , ) ⑮ .
12. The setting of the **P6** (**oF** or **oN**) and **P6** are displayed.
13. Push the Motor Speed Adjustment Button (SPEED  , ) ⑮ .
14. The setting of the **P7** (**Rn** , **Cn** or **Pa**) and **P7** are displayed.
15. Push the Motor Speed Adjustment Button (SPEED  , ) ⑮ .
16. The setting of the **P8** (**oF** or **oN**) and **P8** are displayed.
17. Push the Motor Speed Adjustment Button (SPEED  , ) ⑮ .
18. The setting of the **P9** (**oF** or **oN**) and **P9** are displayed.
19. Push the Motor Speed Adjustment Button (SPEED  , ) ⑮ .
20. The setting of the **PA** (**oF** or **oN**) and **PA** are displayed.
21. Push the Motor Speed Adjustment Button (SPEED  , ) ⑮ .
22. The setting of the **Pb** (**oF** or **oN**) and **Pb** are displayed.
23. Push the Motor Speed Adjustment Button (SPEED  , ) ⑮ .
24. The setting of the **Pc** (**33**) and **Pc** are displayed alternately. The first digit indicates the brightness level of the illumination on the front side of the CONTROLLER, and the second one indicates the illumination on the bottom of the CONTROLLER.
25. You can cycle through the choices by pushing the Motor Speed Adjustment Button (SPEED  , ) ⑮ .
26. Push the Error Reset Button (RESET) ⑳ . **Pd** will be displayed.
27. If you desire to set other parameters, push the Motor Speed Adjustment Button (SPEED  , ) ⑮ to select the parameter that needs to be set.
28. When you are finished setting parameters, turn the Main Power Switch ⑨ OFF.

⑭ **PE** Checking the Error History

Procedure



1. Push the START / STOP Button (START / STOP) ⑯ .
2. Alternately displayed are Error History **H1** and the Error Code.
3. Push the Motor Speed Adjustment Button (SPEED  , ) ⑮ .
4. Alternately displayed are Error History **H2** and the Error Code.
5. Push the Motor Speed Adjustment Button (SPEED  , ) ⑮ .
6. Alternately displayed are Error History **H3** and the Error Code.
7. Push the Motor Speed Adjustment Button (SPEED  , ) ⑮ .
8. Alternately displayed are Error History **H4** and the Error Code.
9. Push the Motor Speed Adjustment Button (SPEED  , ) ⑮ .
10. Alternately displayed are Error History **H5** and the Error Code.
11. You can cycle through the choices by pushing the Motor Speed Adjustment Button (SPEED  , ) ⑮ .
12. Push the Error Reset Button (RESET) ⑰ while **PE** is displayed.
13. If you desire to set other parameters, push the Motor Speed Adjustment Button (SPEED  , ) ⑮ to select the parameter that needs to be set.
14. When you are finished setting parameters, turn the Main Power Switch ⑨ OFF.

Clearing the Error History

1. Push and hold the START / STOP Button (START / STOP) ⑯ for 3 seconds.
2. A beep emits and the Error History will be cleared.
3. Push the Error Reset Button (RESET) ⑰ . **PE** will be displayed.
4. If you desire to set other parameters, push the Motor Speed Adjustment Button (SPEED  , ) ⑮ .
5. When you are finished setting parameters, turn the Main Power Switch ⑨ OFF.

⑮ **Pn** Confirmation of Software Version

Procedure

1. Push the START / STOP Button (START / STOP) ⑯ and the program version number will be displayed.
2. When you finished confirming, push the Error Reset Button (RESET) ⑰ and **Pn** will be displayed.
3. If you desire to set other parameters, push the Motor Speed Adjustment Button (SPEED  , ) ⑮ to select the parameter that needs to be set.
4. When you are finished setting parameters, turn the Main Power Switch ⑨ OFF.

19. BREAK IN PROCEDURE

During transportation, storage or installation the grease inside the bearings will settle. If the spindle is suddenly run at high - speed, the lack of evenly distributed grease will cause excessive heat leading to bearing damage.

After installation, repair, initial operation, or long periods of non operation please follow the break - in procedure.

Please refer to the " BREAK IN PROCEDURE " in Operation Manual of the Motor / Spindle.

20. TROUBLESHOOTING

If a problem or concern occurs, please check the following prior to consulting your dealer.

Trouble	Cause	Inspection / Corrective Active
No buttons on the Control Panel work.	Key Hold function is activated. (The Key Lock LED  is lit.)	Press and hold the Error Reset Button (RESET) ^⑳ for 3 seconds to enable button operations on the Control Panel ^㉑ .
The motor rotating speed cannot be set on the Control Panel ^㉒ .	The DISPLAY (DISP) Button ^㉓ is set to " X 10mA " (X 10mA LED (X 10mA) is lit).	Push the DISPLAY (DISP) Button ^㉓ and select " X 1000min ⁻¹ " (to light up the X 1000min ⁻¹ LED (1000min ⁻¹).
When AUTO mode is selected, the motor rotating speed cannot be set by External Signals (analog voltage, pulse signal, speed point signal).	The parameter $P2$ is $0n$. (If $0n$ is selected, push the Motor Speed Adjustment Button (SPEED \blacktriangledown , \blacktriangle) ^㉔ to set the Motor Rotation Speed.)	Set the parameter $P2$ to $0F$. (Refer to P104 " 18 - 4 ^㉕ $P2$ Setting AUTO Mode for Motor Speed Control ".)
Motor does not rotate.	Power is not supplied.	<ul style="list-style-type: none"> • Make sure to turn ON the Main Power Switch ^⑨ on the front of the CONTROLLER. • Insert the power cord connector correctly into the Main Power Inlet with Power Supply Fuses ^⑩ of the CONTROLLER. • Check if a fuse is blown.
	Motor Cord is not connected to the Motor and CONTROLLER.	Connect the Motor Cord securely to the Motor and CONTROLLER.
	Incompatible motor spindle is connected to the CONTROLLER (The Error Code " EL " is displayed on the Digital Speed Indicator ^⑬).	Connect the connectable motor spindle to the CONTROLLER after released the Error Code " EL " (Refer to P65 " 7. SYSTEM CHART Fig. 3 and 4 " section).
	Connected Motor is not selected.	Select the Motor Connector No. 1 or No. 2 to which the motor is connected. When the control mode is AUTO: Refer to P78 " 15 - 3 - 2 (2) Motor Selection ". When the control mode is MANUAL: Refer to P77 " 15 - 3 - 1 (2) Motor Selection ".
	Control Button (CTRL) ^⑲ is set to Manual mode but trying to start with an External Command Signal through External Input / Output Connector A ^③ .	Start with the Start / Stop Button (START / STOP), or set the Control Button (CTRL) on the Control Panel to Auto mode.

Trouble	Cause	Inspection / Corrective Active
Motor does not rotate.	Control Button (CTRL) ⑰ is set to Auto mode but trying to manually start with the START / STOP Button (START/STOP) ⑱ on the Control Panel ②.	Start with an External Command Signal or set the Control Button (CTRL) ⑰ on the Control Panel ② to Manual mode. (When Start with an External Command Signal, refer to P80 " 16 - 1 (1) Details of External Input / Output Connector A ③ Signals Table. 6 Pin No. 14 ")
When started the motor, " EE " is displayed and motor does not rotate.	Emergency Stop Signal is ' OFF (Open) ' .	Check the setting of parameter P_b . (Refer to P108 " 18 - 4 ⑪ P_b Selection of Emergency Stop Function " section.)
When starting the motor, " E7 " is displayed and motor does not rotate.	Low air pressure.	Adjust to the air pressure 0.25 - 0.3MPa (36.3 - 43.5psi).
An Error Code occurs and motor does not rotate.	An Error has occurred. (Error LED (ERROR) ⑳ is lit.)	Check the P94 " 17 - 3 Resetting System after Error Codes Table. 9 " . Error will not be released until cause of the error has been removed.
Cannot set the increase or decrease of the motor rotation speed.	When using Motor No. 1 : Motor Fixed Speed is set in the P_3 or P_5 parameter. When using Motor No. 2 : Motor Fixed Speed is set in the P_4 or P_6 parameter.	Cancel the parameters for " Fixed Motor Speed Setting " and " Maximum Motor Speed Setting " . When using Motor No. 1 : Refer to P105 " 18 - 4 ③ P_3 Setting Fixed Motor No. 1 Speed " or P105 " 18 - 4 ⑤ P_5 Setting Maximum Motor No.1 Speed " . When using Motor No. 2 : Refer to P105 " 18 - 4 ④ P_4 Setting Fixed Motor No.2 Speed " or P106 " 18 - 4 ⑥ P_6 Setting Maximum Motor No.2 Speed " .
Speed is set incorrectly when using a pulse signal in External Speed Control Mode.	An unallowable pulse-train signal was input.	Refer to parameter P_7 . (Refer to P100 " 18 - 3 ⑦ P_7 Selection of External Speed Control Mode " .)

Trouble	Cause	Inspection / Corrective Active
Cannot set the motor speed to its maximum allowable motor rotation speed.	Either the required speed value is higher than the maximum rotation speed of the motor, or the upper limit of the rotational speed has been set in parameter (P5) or (P6).	Set the Maximum Rotation Speed to a value less than the Motor Rotation Speed set in Parameter (P5) or (P6). (Refer to P105 " 18 - 4 ⑤ (P5) Setting Maximum Motor No. 1 Speed " section.) (Refer to P106 " 18 - 4 ⑥ (P6) Setting Maximum Motor No. 2 Speed " section.)
	Parameter (PR) is (on) when set in AUTO mode. Maximum rotation speed of the Motor by an External Speed Control Voltage is set to the characteristics of 30,000min ⁻¹ .	Check the setting of parameter (PR). (Refer to P108 " 18 - 4 ⑩ (PR) Selection of Selection of Motor Speed Control Voltage / DC+10V Signal Method " section.)
	Air Input Monitoring Override is set in the (P9) parameter to (on) and the motor's maximum speed has been limited to 30,000min ⁻¹ (rpm).	Check the setting of parameter (P9). (Refer to P108 " 18 - 4 ⑨ (P9) Selection of Air Input Monitoring Override " section.)
Cannot change the motor rotation speed on the Speed Point.	Parameter (P7) is not set to (Pa).	Check the setting of parameter (P7). (Refer to P106 " 18-4 ⑦ (P7) Selection of External Speed Control Mode " section.)
	The motor rotation speed is not set in the Speed Point.	
	The rotation speed setting is fixed by parameter (P3) or (P5), (P4) or (P6).	Check the setting for parameter (P3) or (P5), (P4) or (P6). When using Motor No. 1 : Refer to P105 " 18 - 4 ③ (P3) Setting Fixed Motor No. 1 Speed " or P105 " 18 - 4 ⑤ (P5) Setting Maximum Motor No.1 Speed ". When using Motor No. 2 : Refer to P105 " 18 - 4 ④ (P4) Setting Fixed Motor No.2 Speed " or P106 " 18 - 4 ⑥ (P6) Setting Maximum Motor No.2 Speed ".
Spindle does not rotate or rotate smoothly.	The spindles bearings have been damaged.	Replace the ball bearings. (Return to NAKANISHI dealer service.)
	The motor has been damaged.	Replace the motor. (Return to NAKANISHI dealer service.)
Overheating during rotation.	Cutting debris has contaminated the ball bearings, and the ball bearings are damaged.	Replace the ball bearings. (Return to NAKANISHI dealer service.)
Abnormal vibration or noise during rotation.	The tool shank is bent.	Replace the tool.
	Cutting debris has contaminated the ball bearings.	Replace the ball bearings. (Return to NAKANISHI dealer service.)
	The spindle ball bearings have been damaged.	
Tool slippage.	Collet or collet nut are not correctly installed.	Check and clean the collet and collet nut. Reinstall the collet and collet nut.
	The collet and the collet nut are worn.	Replace the collet and collet nut.

Trouble	Cause	Inspection / Corrective Active
High run-out.	The tool is bent.	Change the tool.
	Collet nut is not correctly installed.	Secure the collet and the collet nut correctly.
	The collet and the collet nut are worn.	Replace the collet and the collet nut.
	Inside of the spindle is worn.	Replace the spindle shaft. (Return to NAKANISHI dealer service.)
	Contaminants inside the collet and the collet nut or the spindle.	Clean the collet, collet nut and the inside of the taper and spindle.
	The spindle ball bearings have been damaged.	Replace the ball bearings. (Return to NAKANISHI dealer service.)

21. DISPOSAL OF THE CONTROLLER

When disposal of a CONTROLLER is necessary, follow the instructions from your local government agency for proper disposal of industrial components.

株式会社 **ナカニシ** www.nakanishi-inc.com

本社・工場 〒322-8666 栃木県鹿沼市下日向 700
TEL : 0289(64)3380 FAX : 0289(62)5636

本書の内容は、改善のため予告無しに変更することがあります。

NAKANISHI INC.  www.nakanishi-inc.com

700 Shimohinata, Kanuma, Tochigi 322-8666, Japan

NSK America Corp www.nskamericacorp.com

1800 Global Parkway, Hoffman Estates, IL 60192, USA

Contents are subject to change without notice.