

Hammer Attachment HA - 500

OPERATION MANUAL

Thank you for purchasing the Hammer Attachment " HA - 500 ". This Attachment designed for curving a metal on processing of ornament. The Emax EVOLution control unit and motor or ROTUS air motor and Air Line Kit are required to drive this Attachment. Read this and all the associated component Operation Manuals carefully before use. Always keep this Operation Manual in a place where a user can referred to for reference at any time.

1. CAUTIONS FOR HANDLING AND OPERATION

- Read these warnings and cautions carefully and only use in the manner intended.
- These warnings and cautions are intended to avoid potential hazards that could result in personal injury to the operator or damage to the device. These are classified as follows in accordance with the seriousness of the risk.

Class	Degree of Risk
WARNING	A safety hazard could result in bodily injury or damage to the device if the safety instructions are not properly followed.
CAUTION	A hazard that could result in light or moderate bodily injury or damage to the device if the safety instructions are not followed.

WARNING

- The Attachment is designed for hand use. Never install the Attachment or any hand tool on a machine such as a special purpose machine, NC lathe or mill.
- Do not touch the hammer bit while it is reciprocating. It is very dangerous.
- Wear safety glasses, dust mask and use a protective cover around the hammer bit whenever the hammer bit is reciprocating.
- When installing a hammer bit, tighten the hammer bit correctly and check again the hammer bit before use. Do not over-tighten the hammer bit. This may cause damage to the actuating shaft.
- Do not exceed the Maximum Allowable Motor Rotation Speed, 20,000min⁻¹(rpm).
- When using the Attachment continuously, set the Allowable Motor Rotation Speed to 16,000min⁻¹ (rpm) or less.
- When using the Attachment at the Maximum Allowable Motor Rotation Speed 20,000min⁻¹ (rpm), use the Attachment as a rough indication for less than about 10 minutes.
- When the Attachment and Motor overheat during continuous operation, reduce the motor rotation speed or stop the motor rotation. Wait until the Attachment and the Motor cool down before starting operation again.
- Do not use bent, broken, chipped, out of round or sub-standard hammer bit as they may cause shatter or explode. The hammer bit with bent or cracked may cause some injury to operator.
- Always operate hammer bit within the our specified rotation speed limits. Use of a hammer bit higher than the our specified rotation speed limits could cause damage to the hammer bit and injury to the operator.
- Do not apply excessive force. This may cause hammer bit damage, injury to the operator, loss of concentricity and precision.

CAUTION

- Do not drop or hit this Attachment, as shock can damage to the internal components.
- Be sure to clean the hammer bit and the actuating shaft before replacing the hammer bit. If ground particles or metal chips stick to the inside of actuating shaft, damage to the actuating shaft can occur due to the loss of precision.
- When cleaning an Attachment, stop the Attachment and remove debris with a soft brush or a cloth. Do not blow air into the Attachment with compressed air as foreign particles or cutting debris may get into the ball bearing.
- Always clean the hammer bit before installing the hammer bit in the actuating shaft.
- Do not exceed the capabilities of the Attachment or hammer bit.
- Keep everything in order not to place the rag which could be caught near the Attachment.
- Stop operating immediately when abnormal reciprocating or unusual vibrations are observed. Immediately, please check the content of section " 12. TROUBLESHOOTING "
- Always check if the hammer bit and actuating shaft are damaged before and after operating.
- If the hammer bit show signs of wear or damage, replace it before a malfunction or additional damage occurs.
- After installation, repair, initial operation, or long periods of non operation, please carry out break-in as follow. Start rotating slowly and over a short period of 5 - 10 minutes, increase speed gradually until Maximum Allowable Motor Rotation Speed.
- Do not disassemble, modify or attempt to repair the Attachment. Additional damage will occur to the internal components. Service must be performed by NSK NAKANISHI or an authorized service center.
- When using this Attachment for mass production, please consider the purchase of an additional Attachment to be used as a back-up in case of emergency.

2. BASIC PACKAGE

When opening the package, check if it includes all items listed in " Table. 1 Packing List Contents ".

In the event of any shortage, please contact either NAKANISHI (see the " 4. CONTACT US " section) or your local dealer.

Table. 1 Packing List Contents

HA - 500 • • 1pc.	Hammer Bit • • 2pcs.	Wrench (7 x 5.5) • • 1pc.
Bar Wrench (K - 212) • • 1pc.	Lubricating Oil (with Nozzle) • • 1pc.	Inspection Card • • 1pc.
Operation Manual • • 1set		

*The hammer bit is attached to the Attachment.

3. WARRANTY

We provide a limited warranty for our products. We will repair or replace the products if the cause of failure is due to the following manufactures defects. Please contact us or your local distributor for details.

- Defect in manufacturing.
- Any shortage of components in the package.
- Where damaged components are found when initially opening the package. (This shall not apply if the damage was caused by the negligence of a customer.)

4. CONTACT US

For your safety and convenience when purchasing our products, we welcome your questions. If you have any questions about operation, maintenance and repair of the product, please contact us.

Contact Us

- For U.S. Market
 - Company Name : **NSK America Corp**
Industrial Div.
 - Business Hours : 8:30am to 17:00pm (CST)
(closed Saturday, Sunday and Public Holidays)
 - U.S. Toll Free No. : 800-585-4675
 - Telephone No. : 847-843-7664
 - Fax No. : 847-843-7622
 - Web Address : www.nskamericacorp.com
- For Other Markets
 - Company Name : **NAKANISHI INC.**
 - Business Hours : 8:00am to 17:00pm
(closed Saturday, Sunday and Public Holidays)
 - Telephone No. : +81 (0) 289-64-3520
 - e-mail Address : webmaster-ie@nsk-nakanishi.co.jp

5. FEATURES

- Shaping hammer bit, adjustment of reciprocating stroke spring pressure allow processing various patterns.
- Comfortable grip.
- Reciprocating stroke spring pressure can be adjusted.
- This Attachment has lubricate mechanism on reciprocating parts, and has the quality to last long.

6. SPECIFICATIONS AND DIMENSIONS

6 - 1 Specifications

Model	HA - 500
Max. Reciprocating Cycles	500 times / min
Maximum Allowable Motor Rotation Speed	Less than 20,000min ⁻¹ (rpm) Continuous use motor rotating speed : Less than 16,000min ⁻¹ (rpm)
Applicable Motor	ENK - 410S, ENK - 250T (Emax EVOLution) IM - 300, IM - 301 (Rotus)
*This Attachment can not use the reduction gear.	* When use the Rotus air motor (IM - 300 or the IM - 301), the supply air pressure adjust to the less than 0.3MPa (43.5psi).
Stroke	0.4mm
Stroke Spring Pressure	4.4 - 7.1N Adjustable
Vibration	Less than 2.5m / s ²
Weight	95g
Noise Level at 1m distance	Less than 72dB (A)

Operation Environment	Temperature 0 - 40°C	Humidity MAX.75% (No condensation)	Atmospheric Pressure 700 - 1,060hPa
Transportation and Storage Environment	-10 - + 50°C	10 - 85%	500 - 1,060hPa

WARNING

- When using the Attachment continuously, set the allowable motor rotational speed to 16,000min⁻¹ (rpm) or less.
- When using the Attachment at the Maximum Allowable Motor Speed 20,000min⁻¹ (rpm), use the Attachment as a rough indication for less than about 10 minutes.
- When the Attachment and Motor overheat during continuous operation, reduce the motor rotation speed or stop the motor rotation. Wait until the Attachment and the Motor cool down before starting operation again.

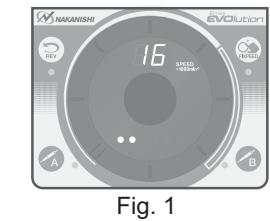

Fig. 1



Fig. 2

6 - 2 Outside View

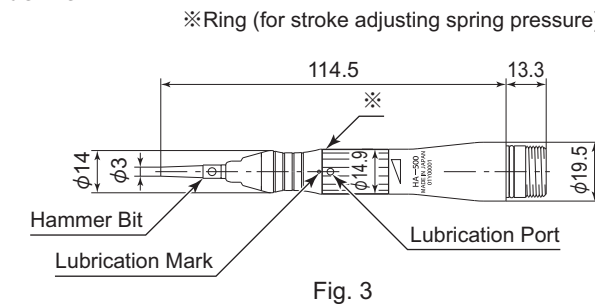

Fig. 3

7. CONNECTION OF THE ATTACHMENT TO THE MOTOR

CAUTION

Make sure your hands and all interlocking parts of the motor and Attachment are clean before connecting the Attachment to the motor. This is critical to preventing contaminants from entering the Attachment or motor.

Align the thread on the front end of the motor and the rear of the Attachment, and turn the Attachment clockwise. If the drive shaft of the motor does not engage properly to the drive dog on the Attachment, it may only turn approximately two threads before stopping. DO NOT FORCE THE TOGETHER. Loosen the Attachment from the motor, rotate the bur by hand then re-try. The drive shaft and the drive dog must be fully engaged. When fully engaged, secure the motor and Attachment (Fig. 4).

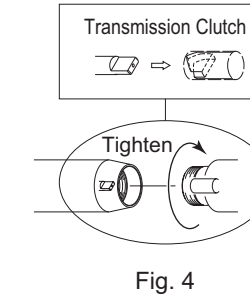

Fig. 4

8. REPLACING THE HAMMER BIT

Remove hammer bit from the Attachment when dress the hammer bit.

Removing

- Place the wrench (7mm) on Nose Cap. Insert the bar wrench into the hole on the hammer bit.
- Turn the bar wrench counterclockwise to remove the hammer bit from the Attachment.

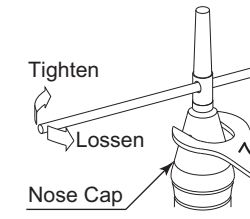

Fig. 5

Mounting

- Attach the hammer bit to the Attachment, and lightly finger tighten.
- Place the wrench (7mm) on Nose Cap. Insert the bar wrench into the hole on the hammer bit.
- Secure the hammer bit by turning the bar wrench clockwise.

CAUTION

Shape only the tip of hammer bit (14mm length portions) shown in Fig. 6 to prevent hammer bit from losing the strength. The hammer bit is made to the following dimensions from SUS - 420 to HRC55.

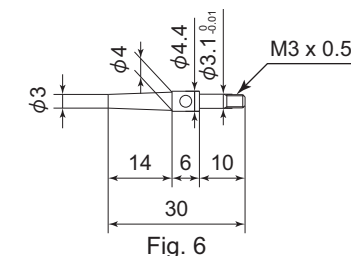

Fig. 6

9. USAGE

- Attach the hammer bit to the Attachment, and lightly finger tighten.
- Place the wrench (7mm) on Nose Cap. Insert the bar wrench into the hole on the hammer bit.
- The Size of patterns depends on the motor speed and the stroke spring pressure.



Fig. 7

10. ADJUSTING STROKE SPRING PRESSURE

Stroke spring pressure can be adjusted between 4.4N and 7.1N. Turn the Ring to WEAK for weaker pressure and to STRONG for stronger pressure. Ring approximately makes four turns.

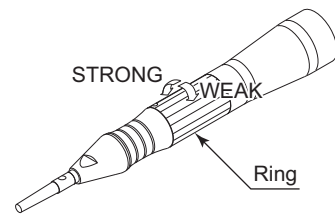

Fig. 8

11. LUBRICATION

CAUTION

Be sure to supplying the lubricating oil to the Lubrication Port once a day (1 - 2 drops).

- Align the Lubricating Port and the " O " mark.
 - Mount the nozzle to the Lubricating Oil and supply to the Lubricating Oil from the Lubricating Port (1 - 2 drops).
- * If initial use or long periods of non-use, supply the Lubricating Oil (10 - 15 drops) into the Lubricating Port to soak the Felt.

Lubricating Oil
Use the Lubricating Oil Class I,
ISO VG15 Liquid Paraffin (Shell
Ondina Oil #15) or NAKANISHI
Lubricating Oil (Z016112)

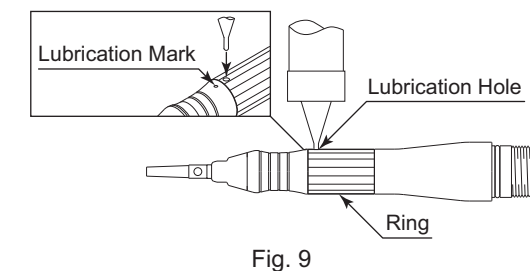

Fig. 9

12. TROUBLESHOOTING

If a problem or concern occur, please check the following items prior to consulting your dealer.

Trouble	Cause	Inspection / Corrective Action
Attachment does not reciprocating or reciprocating smoothly.	The ball bearings have been damaged. The motor has been damaged.	Replace the ball bearings. (Return to NAKANISHI dealer service.) Replace the motor. (Return to NAKANISHI dealer service.)
Overheating during reciprocating.	Cutting debris has contaminated the ball bearing, and the ball bearings are damaged.	Replace the ball bearings. (Return to NAKANISHI dealer service.)
Abnormal vibration or noise during reciprocating.	The hammer bit shank is bent.	Replace the hammer bit.
	Cutting debris has contaminated the ball bearings. The ball bearings have been damaged.	Replace the ball bearings. (Return to NAKANISHI dealer service.)
Hammer bit slippage.	Hammer bit is not correctly installed.	Check and clean the hammer bit. Reinstall the hammer bit and re-tighten. Check the accuracy.
	The hammer bit is worn.	Replace the hammer bit.
High run-out.	Hammer bit is bent.	Replace the hammer bit.
	Hammer bit is not correctly installed.	Secure the hammer bit correctly.
	The hammer bit is worn.	Replace the hammer bit.
	Inside of the actuating shaft is worn.	Replace the actuating shaft. (Return to NAKANISHI dealer service.)
	Contaminants inside the hammer bit or the actuating shaft.	Clean the hammer bit and the inside of the taper and actuating shaft.
The ball bearings have been damaged.	Replace the ball bearings. (Return to NAKANISHI dealer service.)	

13. DISPOSAL OF THE ATTACHMENT

When disposal of an Attachment is necessary, follow the instructions from your local government agency for proper disposal of industrial components.