

LUSTER

NLS-110

OPERATION MANUAL

OM-K0607E 001

Thank you for purchasing the LUSTER NLS-110. It is designed for polishing, lapping and honing after metal mold machining. Please read this operation manual carefully before use.

Warning

- Do not exceed the " Maximum Allowable Motor Rotation Speed " (Refer to " **3** Specifications ").
- When sensing that the LUSTER and motor are overheated during operation, reduce the working force or the motor rotation speed, or stop the operation until the LUSTER cools down before restarting.

1 **Cautions on handling**

- ① Use a protective cover, glasses and/or facemask for your safety during usage.
- ② Do not touch the bur-holder, tool, etc. while it is in a reciprocating motion.
- ③ Do not drop or hit LUSTER, because the shock could damage the internal components.
- ④ Check if the tool/file has been mounted firmly, before operation.
- ⑤ Do not force the tool/file to overload, or the LUSTER may be damaged.
- ⑥ Overloading LUSTER could activate the protective circuit.
- ⑦ Be sure to keep LUSTER/motor away from water. It could cause an electric shock to the operator.
- ⑧ Do not lubricate LUSTER/motor or any bearings in the system, as grease-filled bearings are used.
- ⑨ The LUSTER NLS-110 is powered by the Emax EVOLution control unit NE249.
(Never connect to Emax control unit NE129)

Caution on Vibration

General Warnings for All Vibrating Equipment

- ① Repeated or long-term exposure to excessive vibration may cause temporary or permanent physical injury, particularly to the hands, arms and shoulders.
- ② It is strongly recommended that anyone using vibrating equipment, such as power hand tools, first be physically examined by a doctor and then have regular medical check-ups to make sure the user does not have any medical problems that are being caused or worsened by using vibrating equipment. People who have impaired blood circulation to the hand, past hand injuries, nervous system disorders and Raynaud's disease should not use vibrating equipment.
- ③ If you feel any medical or physical symptoms related to vibration (such as tingling, numbness and white or blue fingers), report the situation to your employer and seek medical advice as soon as possible.
- ④ Avoid smoking while using vibrating equipment, as nicotine reduces the blood supply to the hands and fingers.
- ⑤ Suitable gloves should be worn to reduce the vibration effects on the user.
- ⑥ Tools with the lowest vibration should be used when there is a choice between different processes.
- ⑦ Work schedules should be arranged to include vibration-free periods throughout each day.

Additional Warnings for the Safe Use of LUSTER

- ① LUSTER should only be used after reading and understanding the Operation Manual.
- ② Grip LUSTER as lightly as possible (while still keeping safe control of it). Let LUSTER do the work.
- ③ To ensure your safety, LUSTER should be maintained as explained in this Operation Manual.
- ④ Do not use LUSTER at vibration levels of 2.5 m/s^2 and higher. Select the combination of motor speed and stroke so that the vibration level stays in the shaded area as shown on the chart lower right.
- ⑤ Do not use LUSTER with vibration at 2.5 m/s^2 or higher each day for an extended period of time (Refer to Graph - 1).
- ⑥ If any abnormal vibration occurs stop using LUSTER immediately and return to NAKANISHI for service.
- ⑦ Remove the plug from the control unit when adjusting the stroke length for safety reasons.

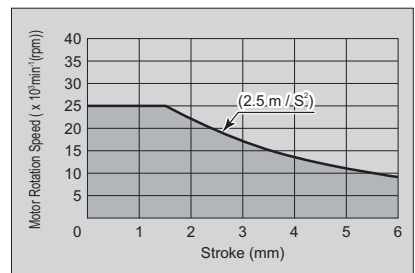

Graph - 1

2 Features

- ① ON/OFF of reciprocation movement is easily done at the grip.
- ② Tools are easy to change.
- ③ Reciprocating speed and stroke can be easily and continuously controlled.
- ④ You can mount various files available on the market.
- ⑤ Mounted tool/file can be easily reoriented onto the work surface.

3 Specifications

Model	NLS - 110
Maximum Allowable Motor Rotation Speed	Less than 25,000min ⁻¹ (rpm)
Stroke	0 - 6mm (0 - 0.236")
Reciprocating frequency	0 - 105 cycles / second
Applicable Control Unit	Emax EVOLution
Weight (With Power Code)	800 g (28.2oz.)
Vibration Level	Use the LUSTER less than 2.5m / s ² (Refer to Graph - 1)
Noise Level at 1m distance	Less than 70dB (A)

	Temperature	Humidity	Atmospheric Pressure
Operation Environment	0 - 40°C	MAX.75% (No condensation)	800 - 1,060hPa
Transportation and Storage Environment	-10 - 50°C	10 - 85%	500 - 1,060hPa

4 Connecting Control Unit

LUSTER NLS-110 has a built-in motor. Insert the cord plug into the control unit as mentioned below.

- Align the cord plug with the jack of the control unit and push in. **(Fig.1)**

5 Adjusting Motor speed (Tool Reciprocating Cycle)

Adjust the motor speed at the control unit.

ON/OFF of the motor can be made either at the grip or at the control unit. **(Fig.1)**

(See the control unit operation manual for control by the switch on unit.)

- Motor stops when ON/OFF switch on the grip is depressed during operation.
- Push the switch on the grip again to re-start the motor.

6 Dimensions and Parts Description

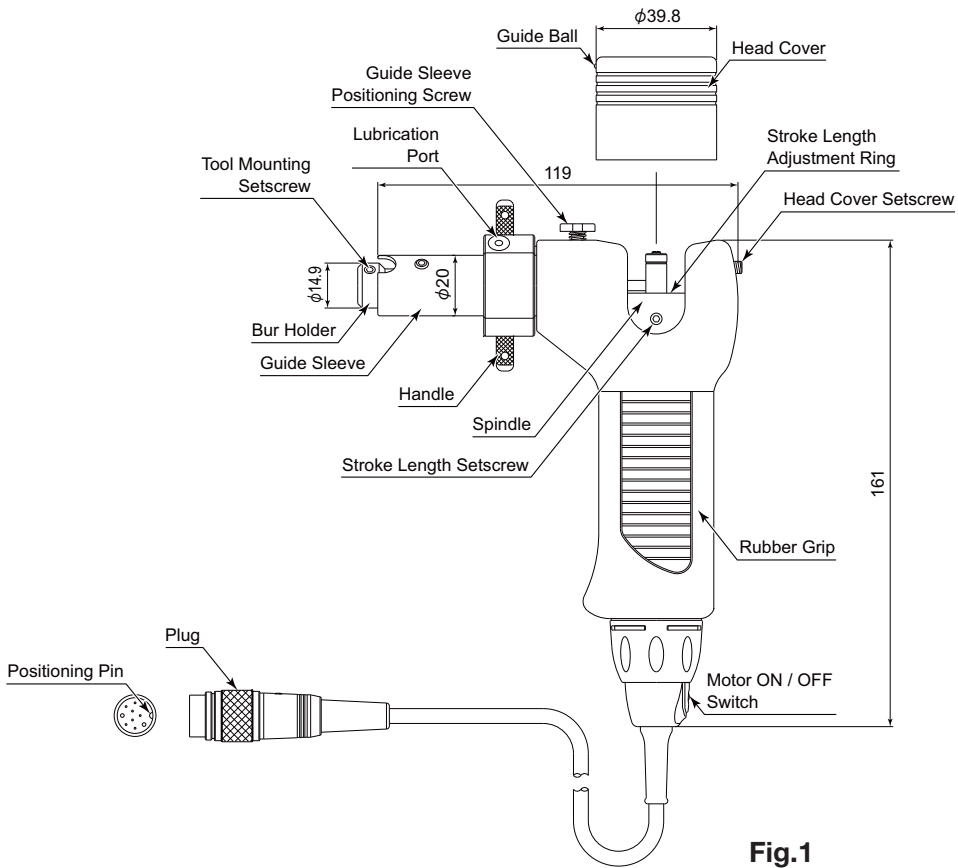

Fig.1

7 Changing the Tool or File

• Mounting

- ① Insert a tool (less than $\phi 3.2$ mm) into the bur holder and tighten the tool mounting setscrew with the supplied Allen Wrench (**Fig.2**).
- ② To mount a larger tool ($\phi 3.2$ mm through $\phi 6.4$ mm), loosen the setscrew, remove the bushing, insert the tool and tighten the setscrew. (To re-install the bushing, align the guide ball on the bushing with the slot in the bur holder.) (**Fig.3**)

• Removing

Loosen the tool mounting setscrew with supplied Allen Wrench, and remove (**Fig.2**).

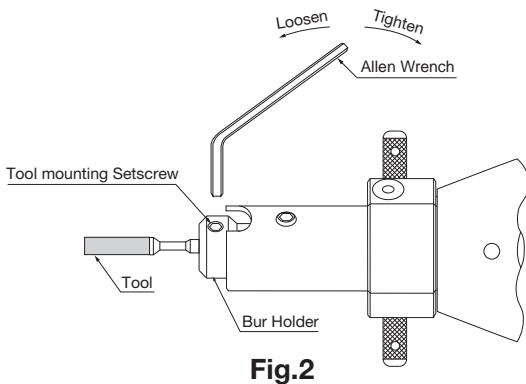

Fig.2

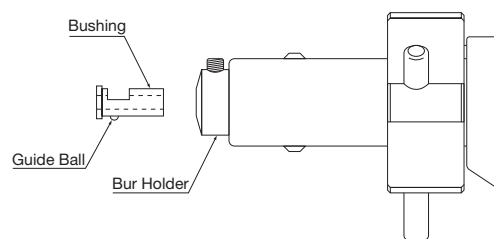

Fig.3

⚠ Caution on Vibration

Remove the plug from the control unit before replacing tool, for your safety. Check if tool/file has been tightened firmly, before operation.

8 Adjusting Stroke Length

- ① Loosen the head cover setscrew with the supplied Allen Wrench (**Fig.1**).
- ② Slide the head cover upward and remove. (**Fig.1**).
- ③ Loosen the stroke length setscrew with the Allen Wrench (**See Fig.4**).
- ④ Turn the adjustment ring, while holding the spindle with your finger, and align the desired stroke length with the indicator line. The stroke length can be adjusted between 0 - 6 mm. (0 - 0.236") (**Fig.5**)
- ⑤ Tighten the stroke length setscrew with the Allen Wrench (**Fig.4**).
- ⑥ Insert the head cover and push it down, aligning the guide groove on LUSTER and the guide ball on the head cover.
- ⑦ Fasten the head cover setscrew with the Allen Wrench (**Fig.1**).
- ⑧ Choose the motor speed in accordance with the stroke length as shown in Graph - 1. Operate LUSTER avoiding abnormal vibration.

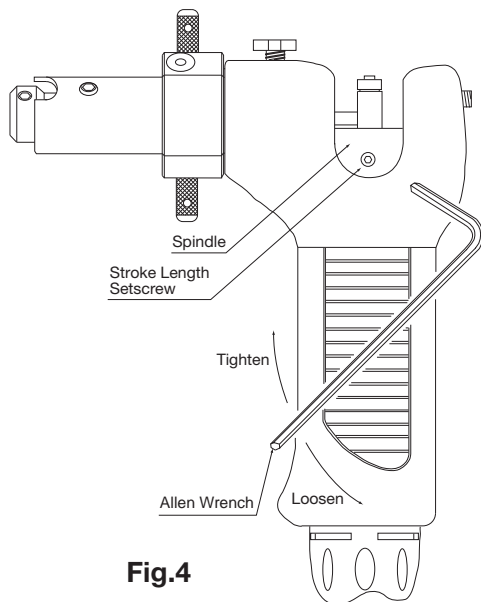

Fig.4

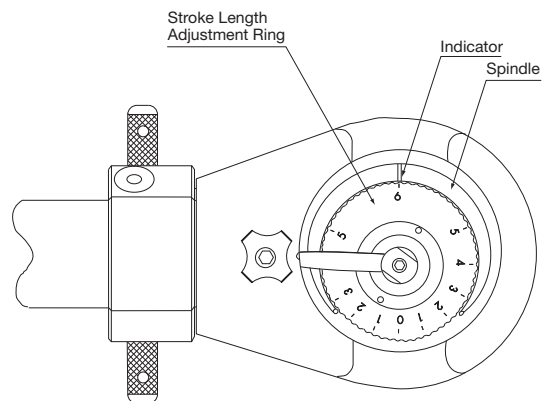

Fig.5

Warning

- Do not exceed the " Maximum Allowable Motor Rotation Speed " (Refer to " **3** Specifications ").
- When sensing that the LUSTER and motor are overheated during operation, reduce the working force or the motor rotation speed, or stop the operation until the LUSTER cools down before restarting.

Caution

Remove the plug from the control unit when adjusting the stroke length for safety reasons.

9 Orientation of Guide Sleeve/Tool

Mounted tool can be re-oriented.

- Loosen the guide sleeve positioning screw to make the guide sleeve smoothly rotate. **(Fig.6)**
This can allow the tool to fit the work surface with ease.
- Fasten the guide sleeve positioning screw to fix tool. **(Fig.6)**
This completes re-orientation of the tool.

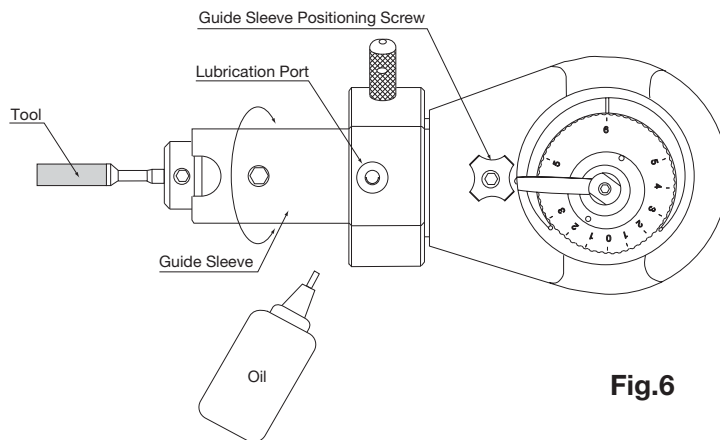

Fig.6

10 Lubrication

Lubricate LUSTER at least once a day from the lubrication port as shown. **(Fig.6)**

In case the supplied oil depletes and NAKANISHI oil cannot be found, use the turbine oil class 1 ISO VG32.

11 Applications

1. Finishing the complicated shapes and sizes. (Fig.7)
(For press dies, Drawing dies, etc.)

- ① Machine by 0.05 mm.
- ② File finish the clearance by 0.02 mm max.
- ③ Heat treat.
- ④ Hone or lap the edges
- ⑤ Final polish by lapping or honing grindstone
- ⑥ Polish the surface of dies

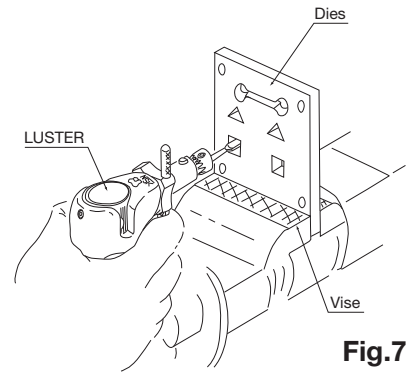

Fig.7

2. Finishing of grooves (Fig.8)

With use of proper tools that are supplied with, finish the surface by filing, lapping, or honing, and final polish.

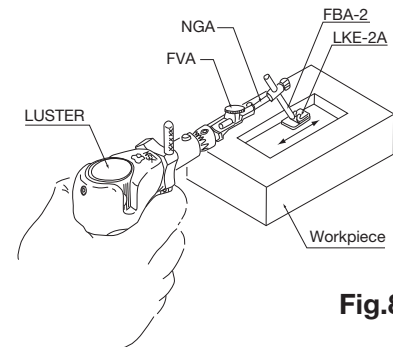

Fig.8

12 Standard Accessories

	<p>VEA (62505) Oil stone or large file can be used. The stone angle can be changed.</p>		<p>LKE-2A (62525) Use with holders. Use for lapping and honing as is. Use with the sandpaper provided or other polishing materials adhered on it.</p>
	<p>VES (62502)</p>		<p>Lubrication Nozzle</p>
	<p>FVA (62751) Spring in radial direction.</p>		
	<p>NGA Holder (62527) Use with FBA-2, SEV.</p>		
	<p>FBA-2 Holder (62526) Use with LIKE-2A.</p>		

- **Sandpaper** : K012-K100(rectangle) (4 different grit sizes) 10 pcs. each kind.
* Rectangle sandpapers in variety of grits are available.
- **Allen Wrench:** 2 mm, 2.5 mm, 3 mm
- **Oil**

13 Typical use of Accessories

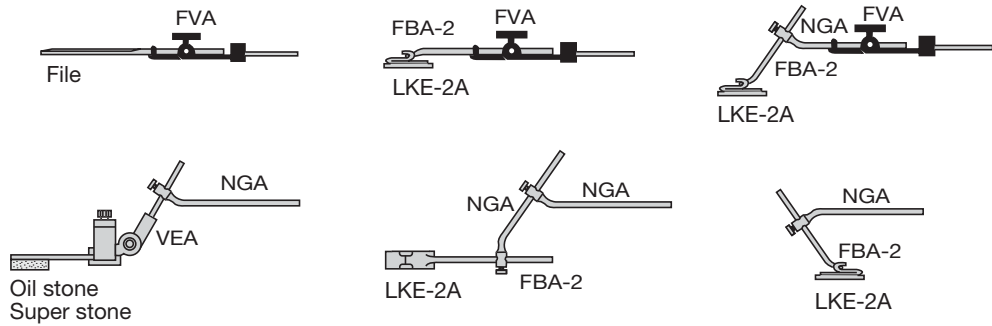

14 Troubleshooting

When the trouble is found, please check the following prior to consulting your dealer.

Trouble	Cause	Inspect / Corrective Action
Reciprocating stroke is poor	Low lubricant	Lubricate Oil properly
Guide Sleeve Slippage	Guide Sleeve Screw improperly	If the guide sleeve is slips after retightening, send to NAKANISHI for repair.
Heat generation during rotation	Ball Bearing worm out by the reason Ground Particles stock in the air of Ball Bearing	Send to NAKANISHI Repair
Abnormal Noise or Unusual vibration during rotation	Ball Bearings worn due to debris particles in the Ball Bearings	Send to NAKANISHI Repair
	Ball Bearing worm out	
Tool will not tighten	The tool mounting setscrew has loosened	Check if the tool mounting setscrew is property positioned. Clean it and retighten.