

スピンドル / Spindle

NR-4040

取扱説明書 / OPERATION MANUAL

日本語 : P1 - P13 / English : P15 - P27

OM-K0641 001





Thank you for purchasing spindle NR -4040. This spindle designed for grinding, drilling and milling, etc. The <E4000 CONTROLLER>, <Brushless Motor> and <Air Line Kit> are required to drive this spindle. Read this Operation Manual carefully before use. Also read <E4000 CONTROLLER>, <Brushless Motor> and <Air Line Kit> Operation Manuals. Always keep this Operation Manual in a place where a user can referred to for reference at any time.

CONTENTS

- 1. CAUTIONS FOR HANDLING AND OPERATION P16**
- 2. FEATURES P18**
- 3. SPECIFICATIONS AND DIMENSIONS..... P18**
- 4. CONNECTION TO THE MOTOR P19**
- 5. CHANGING THE TOOL P20**
- 6. REPLACING THE COLLET CHUCK..... P21**
- 7. INSTALLATION OF THE SPINDLE P22**
- 8. BREAKE-IN PROCEDURE P25**
- 9. CAUTIONS WHEN USING GRINDSTONES AND TOOLS P26**
- 10. TROUBLESHOOTING P27**

1. CAUTIONS FOR HANDLING AND OPERATION

- Read these warnings and cautions carefully and only use in the manner intended.
- These warnings and cautions are intended to avoid potential hazards that could result in personal injury to the operator or damage to the device. These are classified as follows in accordance with the seriousness of the risk.

Class	Degree of Risk
 WARNING	A safety hazard could result in bodily injury or damage to the device if the safety instructions are not properly followed.
 CAUTION	A hazard that could result in light or moderate bodily injury or damage to the device if the safety instructions are not followed.

WARNING

- ① This spindle is not a hand tool. It is designed to be used on CNC machines or special purpose machines.
- ② Do not touch the cutting tool while it is running. It is very dangerous.
- ③ Wear safety glasses, dust mask and use a protective cover around the spindle whenever the spindle is rotating.
- ④ Never connect, disconnect or touch the Connector and Motor Cord Plug with wet hands. This may cause an electric shock.
- ⑤ Never operate or handle the spindle until you have thoroughly read the Operation Manuals and safe operation has been confirmed.
 - 1) To prevent injuries / damages, check the spindle and cutting tool for proper installation, before operating the spindle.
 - 2) Before disconnecting the spindle, always turn the control power off and turn the compressed air supply to the CONTROLLER off. Then it is safe to remove the spindle.
- ⑥ When installing a spindle to a fixed base, make sure the fixed base is grounded in order to avoid the risk of an electric shock.
- ⑦ When installing a tool, tighten the collet chuck correctly and check again the collet chuck and chuck nut before use. Do not over-tighten the collet chuck. This may cause damage to the spindle.
- ⑧ Do not use bent, broken, chipped, out of round or sub-standard tools, as this may cause them to shatter or explode. Tools with fractures or a bent shank will cause injury to the operator. When using a new tool, rotate it in a low speed and increase speed gradually for safety.
- ⑨ Do not exceed the maximum recommended allowable tool speed. For your safety, use speeds below the maximum allowable speed.

WARNING

- ⑩ Do not apply excessive force. This may cause tool slippage, tool damage, injury to the operator or loss of concentricity and precision.

CAUTION

- ① Do not drop or hit this spindle, as shock can damage to the internal components.
- ② Be sure to clean the collet chuck and chuck nut, the inside of the spindle before replacing the tool. If ground particles or metal chips stick to the inside of spindle or the collet chuck, damage to the collet chuck or spindle can occur due to the loss of precision.
- ③ When cleaning a spindle, stop the motor and remove debris with a soft brush or a cloth. Do not blow air into the dust proof cover area (refer to section " 3 - 2 Outside View ") with compressed air as foreign particles or cutting debris may get into the ball bearing.
- ④ Always clean the tool shank before installing the tool in the spindle.
- ⑤ When sizing the correct collet chuck size to the tool shank diameter, a tolerance of $+0 \sim -0.01\text{mm}$ is strongly recommended. A tool shank within the $+0 \sim -0.1\text{mm}$ range is mountable, however, this may cause poor concentricity and or insufficient tool shank gripping force.
- ⑥ Select suitable products or tools for all applications. Do not exceed the capabilities of the spindle or tools.
- ⑦ Carefully direct coolant spray to the tool. Do not spray directly on the spindle body.
- ⑧ Stop working immediately when abnormal rotation or unusual vibration are observed. Afterwards, please check the content of section " 10 TROUBLESHOOTING ".
- ⑨ Always check if the tool, collet chuck or chuck nut are damaged before and after operating.
- ⑩ If the collet chuck or chuck nut show signs of wear or damage, replace them before a malfunction or additional damage occurs.
- ⑪ After installation, repair, initial operation, or long periods of non operation, please refer to section " 8. BREAK-IN PROCEDURE " detailed in Table 1. When checking the spindle, no vibration or unusual sound should be observed during rotation.
- ⑫ Do not disassemble, modify or attempt to repair this spindle. Additional damage will occur to the internal components. Service must be performed by NSK NAKANISHI or an authorized service center.
- ⑬ When using this spindle for mass production, please purchase the another spindle as a spare in case of an emergency.

2. FEATURES

- ① The spindle housing is made from precision ground, hardened, stainless steel (SUS) with an outside diameter of ϕ 40mm.
- ② The spindle utilizes ceramic bearing for 40,000min⁻¹.
- ③ Various sizes of collet chucks are available CH16 3.0mm - 10.0mm. Standard collet chuck is CH16 6.0mm or CH16 6.35mm. (For U.S. market CH16 6.35mm.)

3. SPECIFICATIONS AND DIMENSIONS

3 - 1 Specifications

Model	NR - 4040
Maximum Motor Rotation Speed	40,000min ⁻¹
Spindle Accuracy	Within 1 μ m
Applicable Motor	EM - 4020, EM - 4020A, EM - 4040, EM - 4040A
Weight	700g

Standard Accessories	
<ul style="list-style-type: none"> • Collet Chuck ϕ 6.0mm (CH16 - 6.0) or ϕ 6.35mm (CH16 - 6.35) • • 1pc. (For U.S. market ϕ 6.35mm (CH16 - 6.35)) • Chuck Nut (CHN - 16) • • 1pc. • Wrench (17 x 22) • • 2pcs. 	<ul style="list-style-type: none"> • Wrench (36) • • 1pc. • Operation Manual • • 1set.

* The collet chuck and chuck nut are attached to the spindle.

<Option>

Collet Chuck (CH16 - □□)	ϕ 3.0mm, ϕ 3.175m, ϕ 4.0mm, ϕ 6.0mm, ϕ 6.35mm, ϕ 8.0mm and ϕ 10.0mm
Chuck Nut	CHN - 16

3 - 2 Outside View

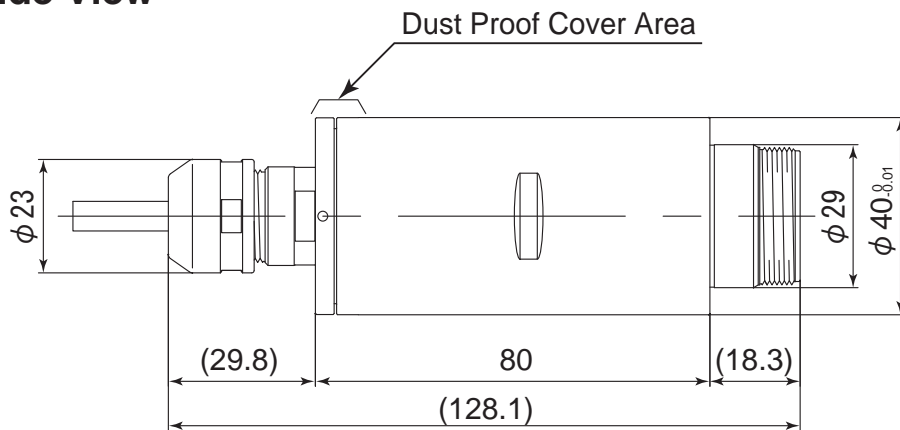

Fig. 1

4. CONNECTION OF THE SPINDLE TO THE MOTOR

⚠ CAUTION

- Make sure your hands and all interlocking parts of the spindle and motor are clean before connecting the motor to the spindle. This is critical to prevent contaminants from entering the motor or spindle.
- When connecting the spindle to the motor, it is best to hold the motor and spindle in a vertical position. Carefully connect by threading the motor on the spindle and avoid mis-alignment, as this will cause damage to the motor and or spindle drive.

Align the threads on the front end of the motor and the rear end of the spindle, then rotate the spindle clockwise. If the drive shaft of the motor does not engage the drive dog on the spindle, it will not be possible for the spindle to rotate. DO NOT FORCE THIS CONNECTION. Turn the spindle back a few threads, rotate the collet cap or spindle shaft slightly by hand until the drive shaft and the drive dog are fully engaged. This may take several attempts. Use the 36mm wrench that have been provided for the final tightening of the spindle to the motor.

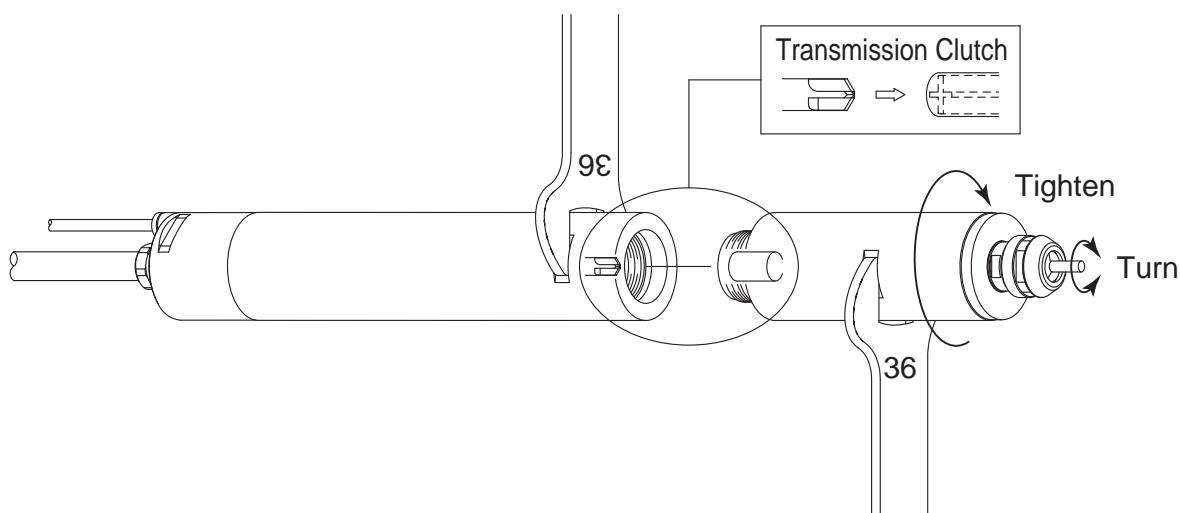

Fig. 2

5. CHANGING THE TOOL

⚠ CAUTION

Do not tighten the collet chuck without inserting a tool or dummy bur, as this will damage the collet chuck, spindle or chuck nut, causing difficulty removing the collet chuck.

RECOMMENDATION

Please minimize the tool overhang amount to maintaining high accuracy.

- ① Set the provided 17mm wrench on the spindle.
- ② Place the provided 22mm wrench on the chuck nut and turn it counterclockwise to loosen the collet chuck and remove the tool. (The first turn will loosen the chuck nut, but the tool will not release and turning will become stiff. Keep turning through the stiffness and the collet chuck will open.)
- ③ Clean the collet chuck and chuck nut, then insert the new tool and tighten the collet chuck by turning clockwise. Do not over-tighten.

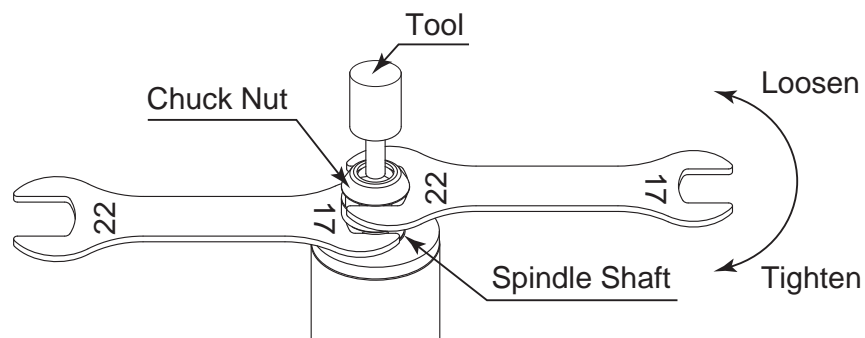

Fig. 3

6. REPLACING THE COLLET CHUCK

⚠ CAUTION

When installing the collet chuck in the chuck nut, make sure to fully engage the latch inside the chuck nut to the groove on the collet chucks outer circumference area. In addition, remember that if the collet chuck is attached without being engaged with the latch of the chuck nut, the collet chuck cannot be removed and this may cause damage to the collet chuck or the spindle.

- ① Remove the tool according to the section " 5. CHANGING THE TOOL " procedure above and remove chuck nut assembly (Fig. 4).
- ② The collet chuck and chuck nut are secured by a groove in the collet chuck and a flange in the chuck nut. To remove the collet chuck hold the chuck nut in one hand and push diagonally down on the collet chuck. The collet chuck should be released (Fig. 5).
- ③ To install the collet chuck, hold the collet chuck at a slight angle, and insert it into the chuck nut (Fig. 6).

Press the collet chuck in the chuck nut by positioning the collet chuck in the chuck nut and pressing down on flat surface (Fig. 5).

Be sure to fully engage the latch inside the chuck nut into the groove on the collet chucks outer circumference area (Fig. 7).

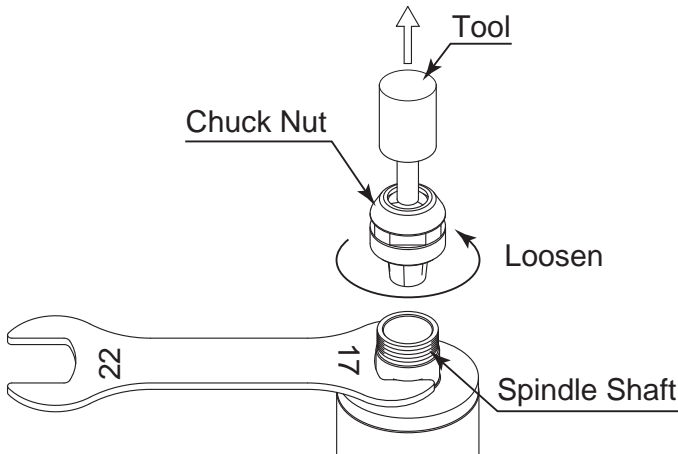

Fig. 4

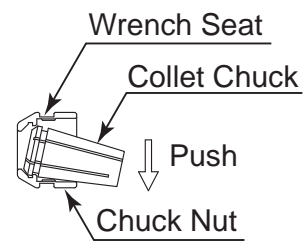

Fig. 5

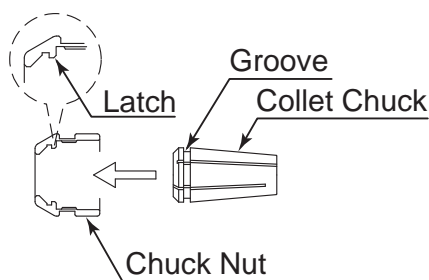

Fig. 6

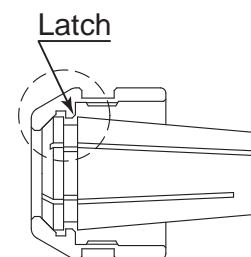

Fig. 7

7. INSTALLATION OF THE SPINDLE

⚠ WARNING

When installing a spindle to a fixed base, make sure the fixed base is grounded in order to avoid the risk of an electric shock.

⚠ CAUTION

- When installing a spindle, do not hit, drop or cause shock to the spindle. This may cause damage to internal components and result in malfunctions.
- When mounting the spindle, be sure to mounting within clamping area etched on the spindle. If the spindle is installed incorrectly, this will cause and damage to the spindle.
- Cautions when tightening the securing bolt of the Split Type Holder
Do not over-tighten the bolt. This may cause damage to spindle's precision. Tighten the bolt until the spindle body can not be turned by hand within the fixture.
Extreme tightening is not necessary or recommended.
Apply working force and check that the spindle is tight before using.

① When mounting a spindle, refer to the Clamping Area etched on the spindle (Fig. 8).

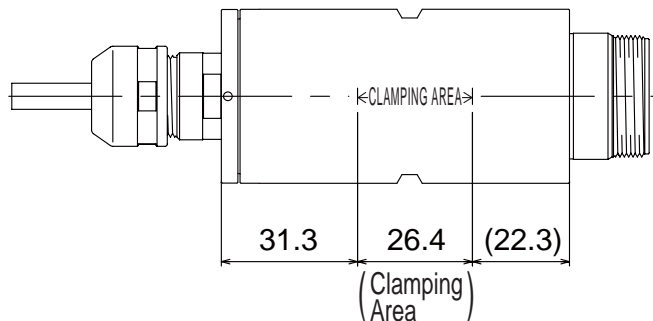

Fig. 8

*When installing a spindle, use a "Grip Ring GR-40 (sold separately)"(Fig. 9) recommended. If the Grip Ring GR-40 (sold separately) cannot be used due to the restriction of dimension and space, install as shown in ② below.

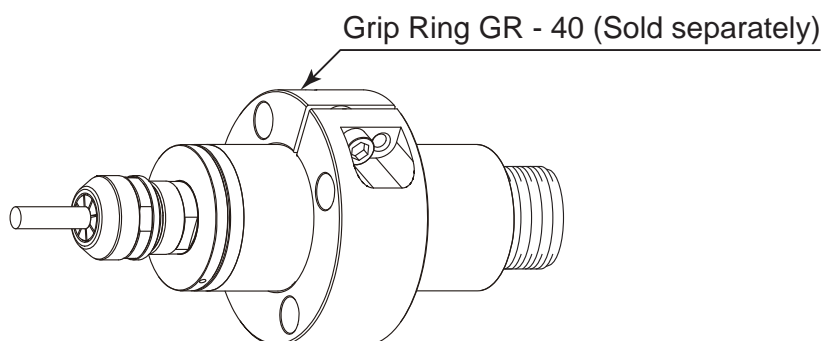

Fig. 9

- ② When installing a spindle to the holder, recommended installation method is shown Fig. 10. Refer to "③ How to fabricate the Split Type Holder".
If this is not possible, install as shown in Fig. 11.

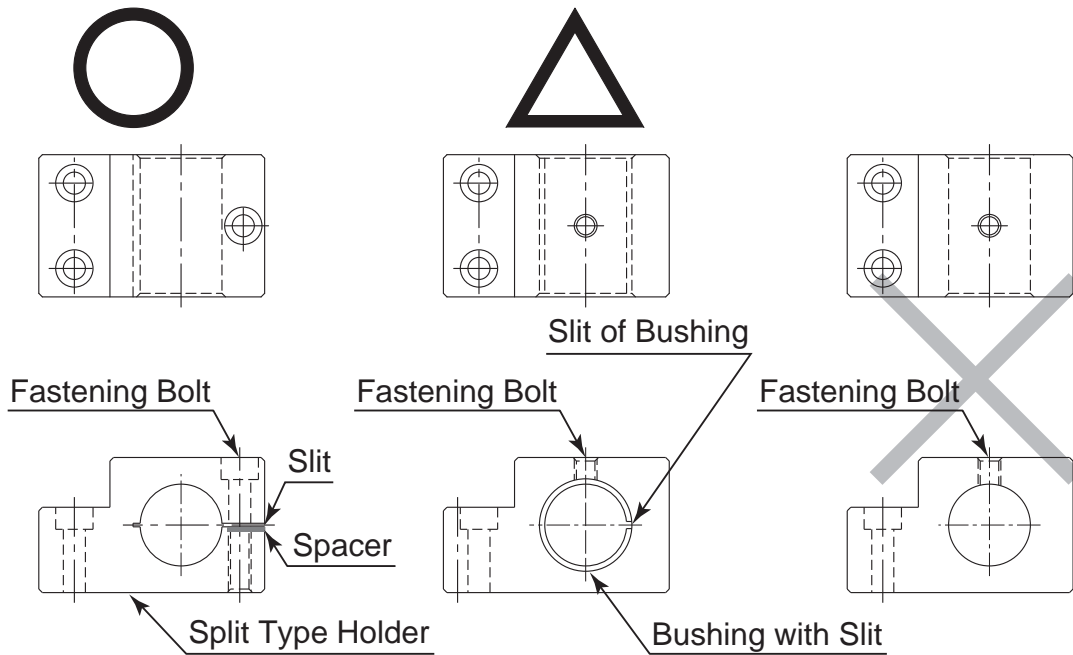

Fig. 10

Fig. 11

Fig. 12

⚠ CAUTION

Do not allow set screws to come directly in contact with the spindle body as shown in Fig. 12, as this will result in damage to the spindle housing and internal components.

When installing, never clamp directly over the bearings, as this will result in bearing damage. (Refer to Fig. 13)

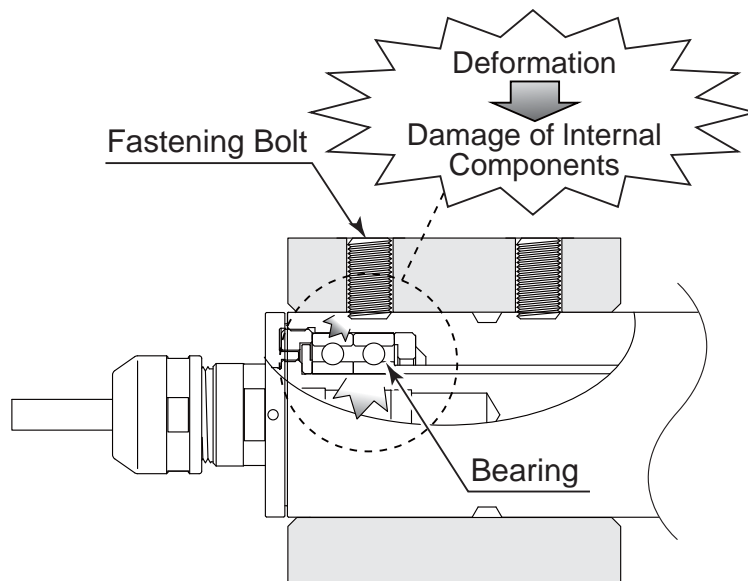

Fig. 13

③ How to fabricate the Split Type Holder

- 1) Rough bore the inside diameter of the Split Type Holder.
- 2) Cut a slit. (Ex. Slit 2mm) wide.
- 3) Tighten the Screw for Removal and Force Open the Slit Area.
- 4) Insert a spacer (Ex. thickness = 2mm) into the Slit Area.
- 5) Loosen the Screw for Removal, and tighten the fastening bolt with the specified torque.
- 6) Finish the Split Type Holder so that the inside diameter of the Split Type Holder is $\phi 40$. With its tolerance range from -0.01mm to -0.015mm , and its roundness and cylindricity of less than $5\mu\text{m}$.
- 7) When inserting the spindle loosen the Fastening Bolt and twist the Screw for Removal, and widen the Slit Area.

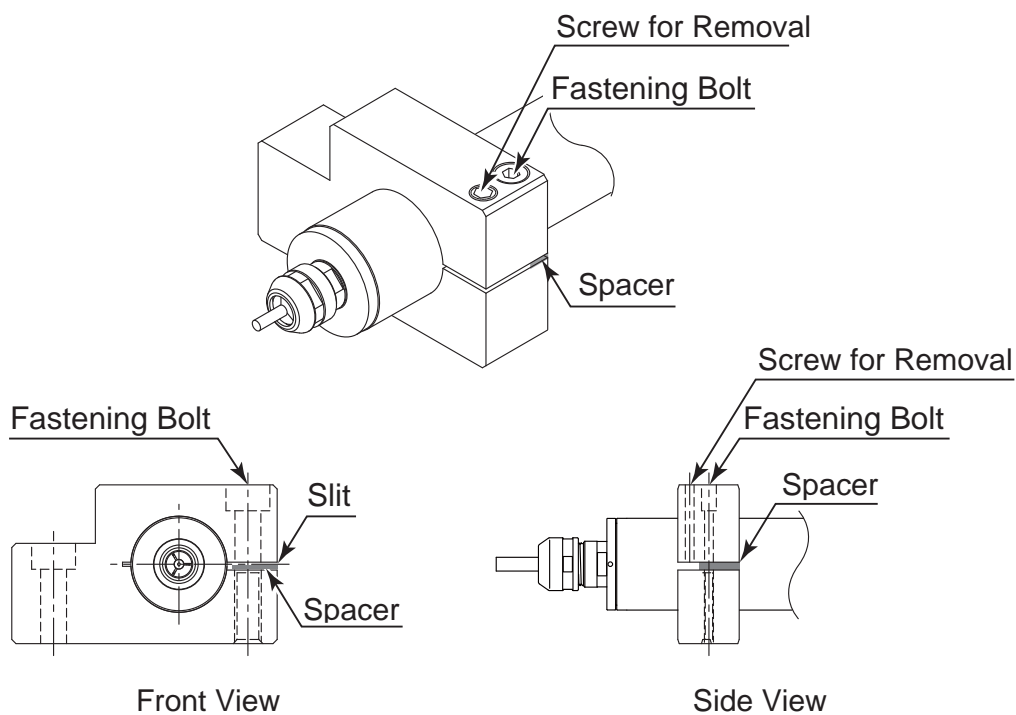

Fig. 14

CAUTION

- How to confirm the correct tightening or clamping of the spindles in the holder:

Measure the current value of the CONTROLLER's power cord by the clamp meter. Fasten the holder so that the increase in the no-load current value (during rotation at the maximum rotation speed) with the spindle fastened is 10mA (for type 200V / 230V) or less, compared to the no-load current value (during rotation at the maximum rotation speed) without fastening the spindle. Do not over-tighten the Fastening Bolt. It may damage spindle's precision and shorten the life of the bearings.

- The final responsibility for ensuring holder's safety for use in a given application is left to the designer of the equipment in which NAKANISHI's spindle is installed.

NAKANISHI offers spindles with a wide variety of capabilities and specifications.

Please carefully check the spindle's specifications against the requirements of your equipment and verify suitability and safety of the Holder prior to initial use.

8. BRAKE-IN PROCEDURE

During transportation, storage or installation, the grease inside the bearings will settle. If the spindle is suddenly run at high-speed, the grease will be ejected from the bearings, causing excessive heat that will cause bearing damage.

After installation, repair, initial operation, or long periods of non operation, please follow the break-in procedure detailed in Table 1.

Table 1

Step	1	2	3	4
Rotation Speed (min ⁻¹)	10,000	20,000	30,000	40,000
Rotation Time (min)	15	10	10	15
Items to Check	No Abnormal Noises.	The spindle housing temperature during the break-in process should not exceed 25 degrees C (36 degrees F) above ambient temperature. Should the spindle exceed this limit, rest the spindle for at least 20 minutes and re-start the break in procedure from the beginning. If the housing temperature rises again and exceeds 25 degrees C (36 degrees F) above ambient temperature, check the spindle and motor for proper installation.		The spindle housing temperature during the break-in process should not exceed 25 degrees C (36 degrees F) above ambient temperature.

9. CAUTIONS WHEN USING GRINDSTONES AND TOOLS

⚠ CAUTION

The maximum surface speed or rpm is always specified for a grindstone. Do not exceed the maximum speed with reference to the calculating chart below. Always follow the grindstone manufacturer's recommendations.

$$\text{Surface Speed (m / s)} = \frac{3.14 \times \text{Diameter (mm)} \times \text{Rotation Speed (min}^{-1}\text{)}}{1,000 \times 60}$$

- ① The proper surface speed for general grindstones is 10 - 30m/s.
- ② Do not exceed 13mm of overhang for mounted grindstones as shown in Fig. 15. If the overhang must exceed 13mm, reduce the motor speed in accordance with table 2.
- ③ Dress the grindstone prior to use.
- ④ Do not use cutting tools with bent or broken shanks, cracks or excessive run-out.
- ⑤ For grinding, the maximum depth of cut should not exceed 0.01mm radially or axially. Reciprocate the tool several times after each pass to eliminate tool pressure.
- ⑥ Always operate tools within the allowable recommended speed of the cutting tools. Use of a cutting tool outside of the allowable speed of the tools could cause damage to the spindle and injury to the operator.
- ⑦ Keep the cutting tool shank and collet chuck clean. If contaminants are left in the collet chuck or chuck nut, excessive run-out will cause damage to the cutting tool and or spindle.
- ⑧ Do not strike or disassemble the spindle.
- ⑨ Please minimize the tool overhang amount to maintaining high accuracy. 13mm is the maximum amount of overhang to maintain high accuracy and safety.

Table 2. Overhang and Speed

Overhang (mm)	Max. Speed (min ⁻¹)
20	N x 0.5
25	N x 0.3
50	N x 0.1

* N = Max. Operating Speed with 13mm overhang.

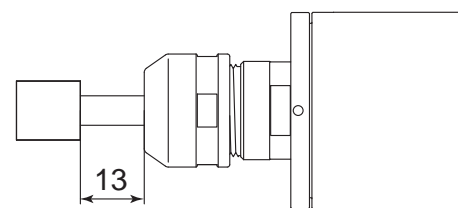

Fig. 15

10. TROUBLESHOOTING

If a problem or concern occurs, please check the following prior to consulting your dealer.

Trouble	Cause	inspection / Corrective Action
Spindle does not rotate or rotate smoothly.	The spindles bearings have been damaged.	Replace the ball bearings. (Return to NAKANISHI dealer service.)
	The motor has been damaged.	Replace the motor. (Return to NAKANISHI dealer service.)
Overheating during rotation.	Cutting debris has contaminated the ball bearings, and the ball bearings are damaged.	Replace the ball bearings. (Return to NAKANISHI dealer service.)
Abnormal vibration or noise during rotation.	The tool shank is bent.	Replace the tool.
	Cutting debris has contaminated the ball bearing.	Replace the ball bearings. (Return to NAKANISHI dealer service.)
	The spindles bearings have been damaged.	
Tool slippage.	Collet chuck or chuck nut are not correctly installed.	Check and clean the collet chuck and chuck nut. Reinstall the collet chuck and chuck nut.
	The collet chuck and the chuck nut are worn.	Replace the collet chuck and chuck nut.
High run-out.	The tool is bent.	Change the tool.
	Chuck nut is not correctly installed.	Secure the collet chuck and the chuck nut correctly.
	The collet chuck and the chuck nut are worn.	Replace the collet chuck and the chuck nut.
	Inside of the spindle is worn.	Replace the spindle shaft. (Return to NAKANISHI dealer service.)
	Contaminants inside the collet chuck and the chuck nut or the spindle.	Clean the collet chuck, chuck nut and the inside of the taper and spindle.
	The ball bearings are worn.	Replace the ball bearings. (Return to NAKANISHI dealer service.)

Refer to the E4000 CONTROLLER Operation Manual.

株式会社 **ナカニシ**

www.nakanishi-inc.com

本社・工場

〒322-8666 栃木県鹿沼市下日向 700

TEL : 0289(64)3380 FAX : 0289(62)5636

NAKANISHI INC. 

www.nakanishi-inc.com

700 Shimohinata, Kanuma, Tochigi 322-8666, Japan

NSK America Corp

www.nskamericacorp.com

1800 Global Parkway, Hoffman Estates, IL 60192, USA

Contents are subject to change without notice.

本書の内容は、改善のため予告無しに変更することがあります。