

エアークイックチェンジスピンドル / Air Quick Change Spindle

NR4040-AQC

取扱説明書 / OPERATION MANUAL

日本語 : P1 - P14 / English : P17 - P32

OM-K0659 | 002



Thank you for purchasing the " NR4040 - AQC " Air Quick Change Spindle. This Spindle features easy replacement of the collet holder by ON / OFF air operation. The Spindle is designed for grinding, small diameter drilling and milling, etc..



The E4000 CONTROLLER, E4000 Series Brushless Motor, and Air Line Kit are required to drive this Spindle. Read this and all the associated component Operation Manuals carefully before use. Always keep this Operation Manual in a place where a user can referred to for reference at any time.

CONTENTS

1. CAUTIONS FOR HANDLING AND OPERATION	P18
2. BASIC PACKAGE	P21
3. WARRANTY	P21
4. CONTACT US	P22
5. FEATURES	P22
6. SPECIFICATIONS AND DIMENSIONS	P23
7. CONNECTION OF THE SPINDLE TO THE MOTOR	P24
8. CONNECTION OF AIR HOSE AND AIR SUPPLY	P25
9. CHANGING THE TOOL AND REPLACING THE COLLET	P26
10. REPLACING THE COLLET HOLDER	P28
11. INSTALLATION OF THE SPINDLE	P29
12. BREAK-IN PROCEDURE	P30
13. CAUTIONS WHEN USING GRINDSTONES AND TOOLS	P30
14. TROUBLESHOOTING	P31
15. DISPOSAL OF THE SPINDLE	P32

1. CAUTIONS FOR HANDLING AND OPERATION

- Read these warnings and cautions carefully and only use in the manner intended.
- These warnings and cautions are intended to avoid potential hazards that could result in personal injury to the operator or damage to the device. These are classified as follows in accordance with the seriousness of the risk.

Class	Degree of Risk
 WARNING	A safety hazard could result in bodily injury or damage to the device if the safety instructions are not properly followed.
 CAUTION	A hazard that could result in light or moderate bodily injury or damage to the device if the safety instructions are not followed.
INFORMATION	Be sure to keep the usage for your safety.

WARNING

- ① This Spindle is not a hand tool. It is designed to be used on CNC machines or special purpose machines.
- ② Do not touch the cutting tool while it is running. It is very dangerous.
- ③ Wear safety glasses, dust mask and use a protective cover around the Spindle whenever the Spindle is rotating.
- ④ Never connect, disconnect or touch the Power Cord Plug or Motor Cord Plug with wet hands. This may cause an electric shock.
- ⑤ Do not replace the collet holder while the brushless motor is rotating. Contact with internal components will damage the Spindle.
- ⑥ When the collet holder is clamped in the Spindle, do not cycle the clamp air ON / OFF. This will cause damage to the Spindle and loss of precision.
- ⑦ Never operate or handle the Spindle and brushless motor until you have thoroughly read the Operation Manuals and safe operation has been confirmed.
 - 1) To prevent injuries / damages, check the Spindle and brushless motor and cutting tool for proper installation, before operating the brushless motor and Spindle.
 - 2) Before disconnecting the Spindle and brushless motor, always turn the control power off and turn the compressed air supply to the CONTROLLER off. Then it is safe to remove the Spindle and brushless motor.
- ⑧ When installing a Spindle to a fixed base, make sure the fixed base is grounded in order to avoid the risk of an electric shock.
- ⑨ When installing a tool in the collet holder, tighten the collet correctly then re-check the collet and collet nut before operating. Do not overtighten the collet. This may cause damage to the collet holder.

WARNING

- ⑩ **Ensure that of the collet holder is correctly mounted in the Spindle before rotating the Spindle.**
- ⑪ **Do not use bent, broken, chipped, out of round or sub-standard tools, as this may cause them to shatter or explode. Tools with fractures or a bent shank will cause injury to the operator. When using a new tool, rotate it in a low speed and increase speed gradually for safety.**
- ⑫ **Do not exceed the maximum recommended allowable tool speed. For your safety, use speeds below the maximum allowable speed.**
- ⑬ **Do not apply excessive force. This may cause tool slippage, tool damage, injury to the operator or loss of concentricity and precision.**

CAUTION

- ① **Do not drop or hit this Spindle, as shock can damage to the internal components.**
- ② **Protect the collet holder taper from the ground particles, dust, metal chips or coolant spray when using the automatic tool change in the machine. Should ground particles, dust, metal chips or coolant spray adhere to the taper, remove them with an air blow before they are inserted into the spindle.**
- ③ **Make sure the inner face of the Spindle and the taper surface of the collet holder are clean (Clean them if debris is found) before replacing the collet holder.**

Ground particles or metal chips stuck to the surface will cause run-out or damage to the collet and spindle. Loss of concentricity will cause spindle damage due to the lack of precision.
- ④ **When cleaning a Spindle, stop the brushless motor and remove debris with a soft brush or a cloth. Do not blow air into the dust proof cover area (refer to contents of page number P23 " 6 - 2 Outside View ") with compressed air as foreign particles or cutting debris may get into the ball bearing.**
- ⑤ **When replacing the tool, make sure the tool shank, collet, collet nut, and inner face of the collet holder are clean. If ground particles or metal chips stick to the inside of the collet, damage to the collet holder or spindle can occur due to the loss of precision.**
- ⑥ **Always clean the tool shank before installing the tool in the Spindle.**
- ⑦ **When sizing the correct collet size to the tool shank diameter, a tolerance of +0 ~ - 0.01mm is strongly recommended. A tool shank within the +0 ~ - 0.1mm range is mountable, however, this may cause poor concentricity and or insufficient tool shank gripping force.**
- ⑧ **Select suitable products or tools for all applications. Do not exceed the capabilities of the Spindle or tools.**



CAUTION



- ⑨ When replacing the collet holder, the air supply pressure must be 0.6MPa to the Clamp / Unclamp air inlet joint of the spindle. If insufficient air pressure is supplied, the collet holder may not be released.
- ⑩ Do not stop the supply cooling air for motor during operation of the machine. Removing the air pressure from the Motor / Spindle causes a loss of purging, allowing the Motor / Spindle to ingest coolant. This will cause damage to the Motor / Spindle.
- ⑪ Carefully direct coolant spray to the tool. Do not spray directly on the Spindle body. If large amount spray directly on the Spindle, it may cause excess load of the motor rotation with loss of durability to the Motor / Spindle.
- ⑫ Stop working immediately when abnormal rotation or unusual vibration are observed. Afterwards, please check the contents of page number P31 " 14. TROUBLESHOOTING ".
- ⑬ Always check if the tool, collet, collet nut, collet holder, connection hose and supply air hose are not damaged before and after operating.
- ⑭ If the collet, collet nut or the collet holder show signs of wear or damage, replace them before a malfunction or additional damage occurs.
- ⑮ The Duty Cycle for opening / closing the collet holder is approximately 150,000 tool changes. Inspection and repair may be necessary if 150,000 cycles are exceeded. Return to a NAKANISHI dealer for service.
- ⑯ After installation, repair, initial operation, or long periods of non operation, please refer to contents of page number P30 " 12. BREAK-IN PROCEDURE " detailed in Table. 2. When checking the Spindle, no vibration or unusual sound should be observed during rotation.
- ⑰ Do not disassemble, modify or attempt to repair this Spindle. Additional damage will occur to the internal components. Service must be performed by NSK NAKANISHI or an authorized service center.
- ⑱ When using this Spindle for mass production, please consider the purchase the another Spindle as a spare in case of an emergency.
- ⑲ Securely connect the compressor supply connection hose and the air hose to the Air Line Kit and the motor and Spindle to avoid accidental disconnection during use.

2. BASIC PACKAGE

When opening the package, check if it includes all items listed in " Table.1 Packing List Contents ".

In the event of any shortage, please contact either NAKANISHI (see the " 4. CONTACT US " section) or your local dealer.

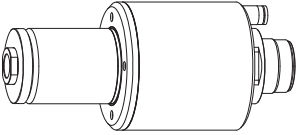
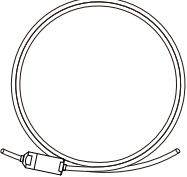
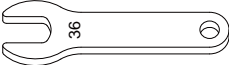
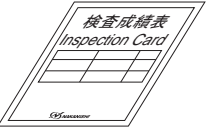
Table. 1 Packing List Contents

<p>NR4040 - AQC Spindle • • 1pc.</p> 	<p>φ6mm Filter with Air Hose • • 1pc.</p> 
<p>Wrench (36mm) • • 1pc.</p> 	<p>Inspection Card • • 1pc.</p> 
<p>Operation Manual • • 1set</p> 	

*The collet holder, collet, and collet nut are sold separately.

3. WARRANTY

We provide a limited warranty for our products. We will repair or replace the products if the cause of failure is due to the following manufactures defects. Please contact us or your local distributor for details.

- (1) Defect in manufacturing.
- (2) Any shortage of components in the package.
- (3) Where damaged components are found when initially opening the package.
(This shall not apply if the damage was caused by the negligence of a customer.)

4. CONTACT US

For your safety and convenience when purchasing our products, we welcome your questions. If you have any questions about operation, maintenance and repair of the product, please contact us.

Contact Us

● For U.S. Market

Company Name	:	NSK America Corp Industrial Div.
Business Hours	:	8:30am to 17:00pm (CST) (closed Saturday, Sunday and Public Holidays)
U.S. Toll Free No.	:	800-585-4675
Telephone No.	:	847-843-7664
Fax No.	:	847-843-7622
Web Address	:	www.nskamericacorp.com

● For Other Markets

Company Name	:	NAKANISHI INC. 
Business Hours	:	8:00am to 17:00pm (closed Saturday, Sunday and Public Holidays)
Telephone No.	:	+81 (0) 289-64-3520
e-mail Address	:	webmaster-ie@nsk-nakanishi.co.jp

5. FEATURES

- ① The collet holder can be replaced automatically by putting ON / OFF the air.
- ② The Spindle housing is made from precision ground, hardened, stainless steel (SUS).
- ③ There are 2 types of collet holders. Various sizes of mounting collets are available depending on the collet holder used (CHK 0.5mm - 6.35mm or CH16 ϕ 3.0mm, ϕ 3.175mm, ϕ 4.0mm, ϕ 6.0mm, ϕ 6.35mm, ϕ 8.0mm and ϕ 10.0mm).

7. CONNECTION OF THE SPINDLE TO THE MOTOR

⚠ CAUTION

- Make sure your hands and all interlocking parts of the Spindle and brushless motor are clean before connecting the brushless motor to the Spindle. This is critical in preventing contaminants from entering the brushless motor or Spindle.
- When connecting the Spindle to the brushless motor, it is best to hold the brushless motor and Spindle in a vertical position. Carefully connect by threading the brushless motor on the Spindle and avoid mis-alignment, as this will cause damage to the brushless motor and or Spindle drive.

Align the threads on the front end of the brushless motor and the rear end of the Spindle, then turn the Spindle clockwise.

If the drive shaft of the brushless motor does not engage the drive dog on the Spindle smoothly, DO NOT FORCE THEM TO SEAT. Tighten the Spindle after rotating the Dust Proof Cover by hand to engage the drive shaft and the drive dog. Use the provided 36mm wrenches for final tightening of the Spindle to the brushless motor.

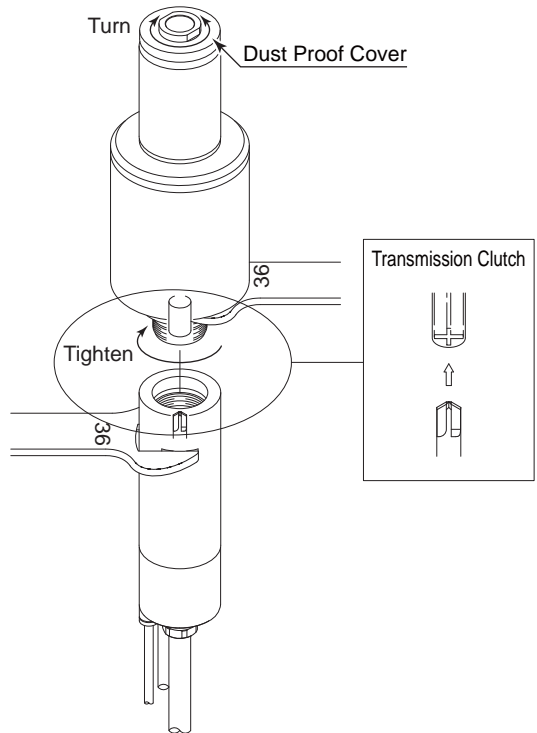

Fig. 2

8. CONNECTION OF AIR HOSE AND AIR SUPPLY

CAUTION

Securely connect the air hose to the brushless motor and air line kit to avoid accidental disconnection and injury to the operator during use.

- (1) Connect the provided ϕ 6mm air hose with filter and 3-way valve to Air Inlet Joint shown in Fig. 3.
- (2) Supply clean air from air compressor through air filter or air dryer to the 3-way valve at the air pressure : 0.6MPa (87psi).

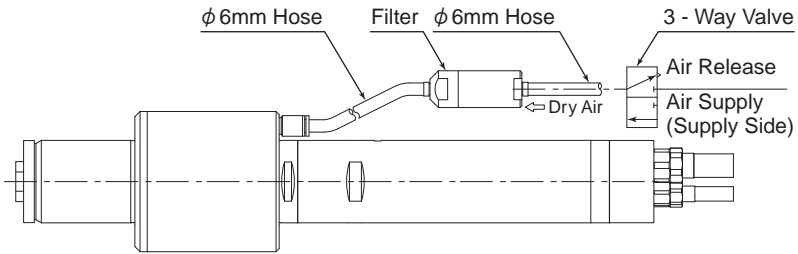

Fig. 3

CAUTION

Ensure that the pressure at the spindle ATC Inlet is 0.6MPa (87psi). As illustrated in the picture, measure the pressure as close to the spindle as possible.

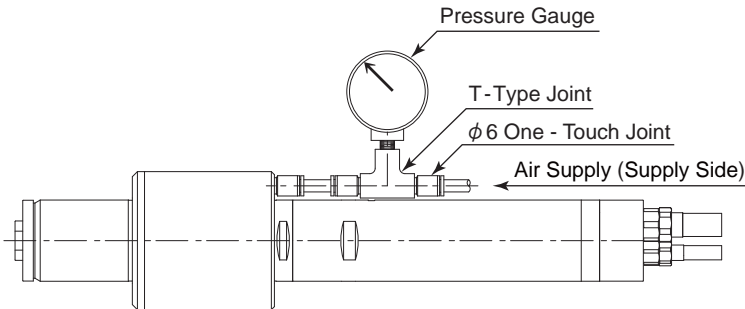

Fig. 4

9. CHANGING THE TOOL AND REPLACING THE COLLET —

⚠ CAUTION

- Do not tighten the collet without inserting a tool or dummy bur, as this will damage the collet, collet holder or collet nut, causing difficulty removing the collet.
- When installing the collet in the collet nut, make sure to fully engage the latch inside the collet nut to the groove on the collets outer circumference area. In addition, remember that if the collet is attached without being engaged with the latch of the collet nut, the collet cannot be removed and this may cause damage to the collet or the collet holder.

RECOMMENDATION

Please minimize the tool overhang amount to maintaining high accuracy.

9 - 1 How to Replace Collets using the Provided Wrenches

- (1) Attach the collet to the collet nut. Be sure to fully engage the latch inside the collet nut to the groove on the collets outer circumference area (Fig. 5, Fig. 6) (Install the collet in the collet nut by positioning the collet in the collet nut and pressing down on flat surface (Fig. 7)).
- (2) Attach the collet and collet nut to the collet holder and lightly finger tighten. (Do not completely tighten until the end) (Fig. 8).
- (3) Insert the tool in to the collet and position the wrench on the collet holder. Position the wrench on the collet nut, then tighten the collet nut by turning clockwise (Fig .9).
- (4) When removing the tool, set the wrench on the collet nut and turn it counterclockwise to loosen the collet and remove the tool (The first turn will loosen the collet nut, but the tool will not release and turning will become stiff. Keep turning through the stiffness and the collet will open.).
- (5) When removing the collet, the collet and collet nut are secured by a groove in the collet and a flange in the collet nut. To remove the collet hold the collet nut in one hand and push diagonally down on the collet. The collet should be released (Fig. 7).

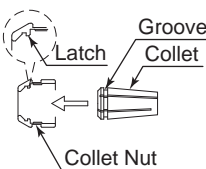

Fig. 5

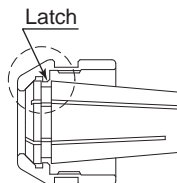

Fig. 6

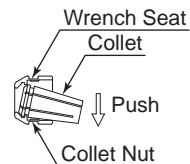

Fig. 7

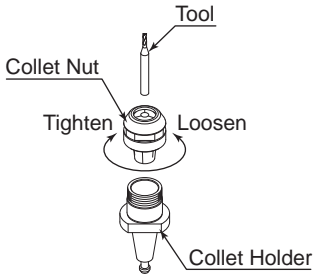

Fig. 8

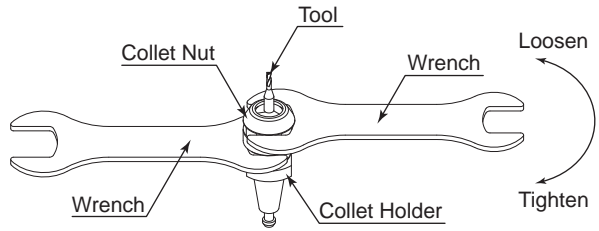

Fig. 9

9 - 2 Tool Replacement using a Preset Adapter

RECOMMENDATION

Adjust the tool extension length using the preset adapter.

- (1) Affix the preset adapter to the tool holder (ϕ 20mm) etc.
- (2) Align the collet holder to the drive dog notch of the preset adapter, and insert the collet holder (Fig. 10).
- (3) Attach the collet and collet nut to the collet holder, and lightly finger tighten. (Do not tighten until the end) (Fig. 11).
- (4) Insert the tool into the collet and set the wrench on the collet holder. Set the wrench on the collet nut, and tighten the collet nut by turning clockwise (Fig. 12).

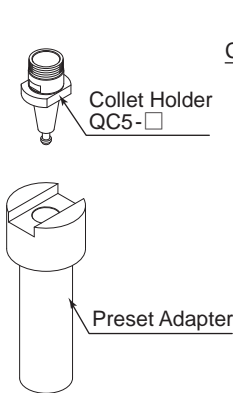

Fig. 10

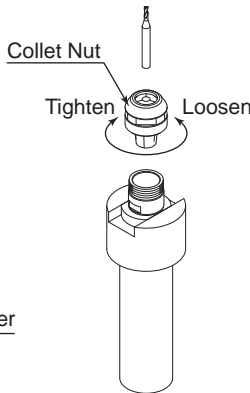

Fig. 11

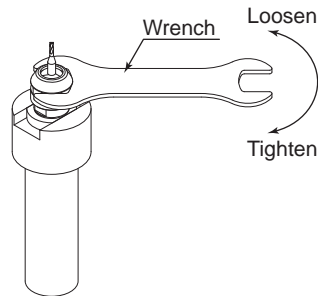

Fig. 12

10. REPLACING THE COLLET HOLDER

⚠ WARNING

- When replacing the collet holder, be sure to stop the Motor. If the collet holder replaced while the motor is rotating, the Spindle will incur internal damage.
- When collet holder is not attached to the Spindle, do not turn ON / OFF of the air operation. Because this will cause damage to the Spindle or loss of precision.

⚠ CAUTION

- When the air is supplied to the inlet joint of the Spindle, the collet holder will be pushed out by exhausting the coolant air of brushless motor from the edge of Spindle. Be careful not to be damaged to the tool or be injured.
- Use the air ON / OFF valve through which the air can be exhausted. Do not use 2 way valve, because the 2 way valve is not exhausted and the collet is not closed.

- (1) Stop the motor rotation and confirm the rotation has stopped.
- (2) Supply air pressure : 0.6MPa (87psi) to Air Inlet Joint through 3-way valve. Then, the collet holder will be removed.
Have a tool holder ready beforehand, protect the tool from damage.
- (3) Replace the collet holder.
- (4) Exhaust the air through 3-way valve. The collet holder will be fixed firmly.
- (5) When installing the collet holder into the spindle, set the collet holder a distance of 1.2 - 1.8mm from the face of the spindle.

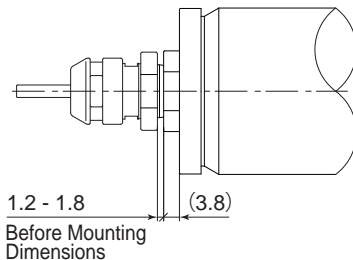

Fig. 13 Before Clamping

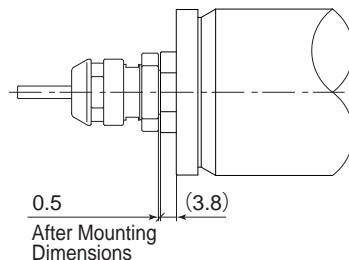

Fig. 14 After Clamping

- * After installing the Collet Holder to the Spindle, the Collet Holder alignment can be checked utilizing a Laser Displacement Sensor as illustrated in Fig. 15.

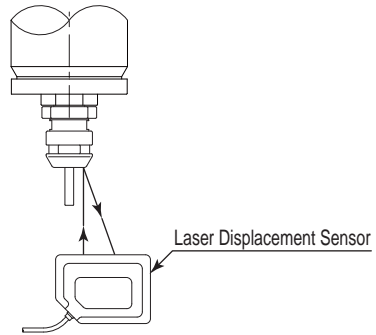

Fig. 15

11. INSTALLATION OF THE SPINDLE

! WARNING

Whenever connecting a Spindle to a brushless motor, or when installing a Spindle to a fixed base, ensure that the fixed base is grounded in order to avoid risk of an electric shock.

! CAUTION

When installing a Spindle, do not hit, drop or cause shock to the Spindle. This may cause damage to internal components and result in malfunctions.

- (1) Insert the Spindle housing diameter (ϕ 40mm) area into the fixed base holder of the machine.
Insert the rear side of the Spindle housing diameter (ϕ 40mm) area into the holder, in consideration of the position of the Air Inlet Joint.
- (2) Secure the Spindle into the holder by using the bolts (4pcs.) and the Mounting Screw Hole (4 locations) on the Spindle as shown in Fig. 16 and 17.

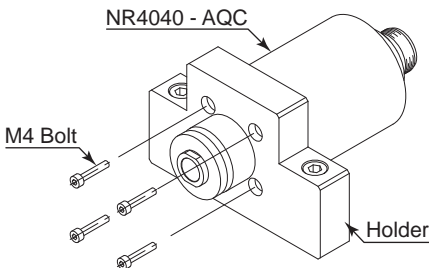

Fig. 16 Front side

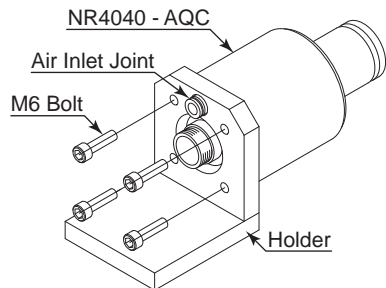

Fig. 17 Rear side

12. BREAK-IN PROCEDURE

During transportation, storage or installation, the grease inside the bearings will settle. If the spindle is suddenly run at high-speed, the grease will be ejected from the bearings, causing excessive heat that will cause bearing damage.

After installation, repair, initial operation, or long periods of non operation, please follow the break-in procedure detailed in Table. 2.

Table. 2

Steps	1	2	3	4
Rotation Speed (min ⁻¹) (rpm)	10,000	20,000	30,000	40,000
Rotation Time (min)	15	10	10	15
Items to Check	No Abnormal Noises.	The Spindle housing temperature during the break-in process should not exceed 20 degrees C (36 degrees F) above ambient temperature. Should the Spindle exceed this limit, rest the Spindle for at least 20 minutes and re-start the break in procedure from the beginning. If the housing temperature rises again and exceeds 20 degrees C (36 degrees F) above ambient temperature, check the Spindle and motor for proper installation.		The Spindle housing temperature during the break-in process should not exceed 20 degrees C (36 degrees F) above ambient temperature.

13. CAUTIONS WHEN USING GRINDSTONES AND TOOLS

CAUTION

The maximum surface speed or rpm is always specified for a grindstone. Do not exceed the maximum speed with reference to the calculating chart below. Always follow the grindstone manufacturer's recommendations.

$$\text{Surface Speed (m / s)} = \frac{3.14 \times \text{Diameter (mm)} \times \text{Rotation Speed (min}^{-1}\text{) (rpm)}{1,000 \times 60}$$

- (1) The proper surface speed for general grindstones is 10 - 30m / s.
- (2) Do not exceed 13mm of overhang for mounted grindstones as shown in Fig. 18. If the overhang must exceed 13mm, reduce the motor speed in accordance with Table. 3.
- (3) Dress the grindstone prior to use.
- (4) Do not use cutting tools with bent or broken shanks, cracks or excessive run-out.

- (5) For grinding, the maximum depth of cut should not exceed 0.01mm radially or axially. Reciprocate the tool several times after each pass to eliminate tool pressure.
- (6) Always operate cutting tools within the allowable recommended speed of the cutting tools. Use of a cutting tool outside of the allowable speed of the cutting tools could cause damage to the Spindle and injury to the operator.
- (7) When replacing the tool, make sure the tool shank, collet, collet nut, and inner face of the collet holder are clean. If ground particles or metal chips stick to the inside of the collet, damage to the collet holder or Spindle can occur due to the loss of precision.
- (8) Do not strike or disassemble the Spindle.
- (9) Please set the cutting tools to minimize the overhang. 13mm is the maximum amount of overhang to maintain high accuracy and safety.

Table. 3 Overhang and Speed

Overhang (mm)	Max. Speed (min ⁻¹) (rpm)
20	N x 0.5
25	N x 0.3
50	N x 0.1

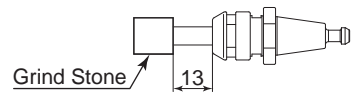

Fig. 18

* N = Max. Operating Speed with 13mm overhang.

14. TROUBLESHOOTING

If a problem or concern occurs, please check the following prior to consulting your dealer.

Trouble	Cause	Inspection / Corrective Action
Spindle does not rotate or rotate smoothly.	The spindles ball bearings have been damaged.	Replace the ball bearings. (Return to NAKANISHI dealer service.)
	The motor has been damaged.	Replace the motor. (Return to NAKANISHI dealer service.)
Overheating during rotation.	Cutting debris has contaminated the ball bearings, and the ball bearings are damaged.	Replace the ball bearings. (Return to NAKANISHI dealer service.)
Abnormal vibration or noise during rotation.	The tool shank is bent.	Replace the tool.
	Cutting debris has contaminated the ball bearing.	Replace the ball bearings. (Return to NAKANISHI dealer service.)
Collet holder slippage.	The spindles ball bearings have been damaged.	
	The collet holder is worn or damaged.	Replace the collet holder.
	The internal components of the Spindle are worn or damaged.	Replace the internal components of the Spindle. (Return to NAKANISHI dealer service.)

Trouble	Cause	Inspection / Corrective Action
Cannot clamp a collet holder.	Poor the air hose connection.	Check all threaded joints and re-tighten if necessary.
	The air hose has been damaged.	Replace the air hoses.
	Low air pressure.	Check the Compressor, Air Circuit, and Regulator.
Tool slippage.	Collet or collet nut are not correctly installed.	Check and clean the collet and collet nut. Reinstall the collet and collet nut.
	The collet and the collet nut are worn.	Replace the collet, collet nut and collet holder.
High run-out.	The tool is bent.	Change the tool.
	Collet nut is not correctly installed.	Secure the collet and the collet nut correctly.
	The collet, collet nut or collet holder are worn.	Replace the collet, collet nut or collet holder.
	Inside of the Spindle is worn.	Replace the Spindle shaft. (Return to NAKANISHI dealer service.)
	Contaminants inside the collet, collet nut and collet holder or the Spindle.	Clean the collet, collet nut and collet holder or the Spindle.
	The Spindle ball bearings are worn.	Replace the ball bearings. (Return to NAKANISHI dealer service.)

Refer to Brushless Motor and E4000 CONTROLLER Operation Manuals.

15. DISPOSAL OF THE SPINDLE ---

When disposal of a Spindle is necessary, follow the instructions from your local government agency for proper disposal of industrial components.

株式会社 **ナカニシ**
www.nakanishi-inc.com

本社・工場
〒322-8666 栃木県鹿沼市下日向 700
TEL : 0289(64)3380 FAX : 0289(62)5636

本書の内容は、改善のため予告無しに変更することがあります。

NAKANISHI INC. 

www.nakanishi-inc.com

700 Shimohinata, Kanuma, Tochigi 322-8666, Japan

NSK America Corp

www.nskamericacorp.com

1800 Global Parkway, Hoffman Estates, IL 60192, USA

Contents are subject to change without notice.