

# 90° Angle Spindle

# RA-100

## OPERATION MANUAL

OM-K0047E 001

Thank you for purchasing 90° Angle Spindle RA-100. This spindle is designed for use in corners, ID bores, drilling and milling on the side of the workpiece and other areas that are difficult to work with a straight type spindle. The E2530 <Control Unit>, <Electric Motor> or <Air Motor> and <Air Line Kit with Lubricator combination> are required to drive this spindle. Read this Operation Manual carefully before use. Also read E2530 <Control Unit>, <Electric Motor> or <Air Motor> and <Air Line Kit> Operation Manual.

### 1. CAUTIONS FOR HANDLING AND OPERATION

- Read these warnings and cautions carefully and only use in the manner intended.
- These warnings and cautions are intended to avoid potential hazards that could result in personal injury or damage to the device. These are classified as follows in accordance with the seriousness of the risk.

Class	Degree of Risk
<b>WARNING</b>	A safety hazard could result in bodily injury or damage to the device if the safety instructions are not properly followed.
<b>CAUTION</b>	A hazard that could result in light or moderate bodily injury or damage to the device if the safety instructions are not followed.

#### WARNING

- This spindle is not a hand tool. It is designed to be used on CNC machines or special purpose machines.
- Do not touch the cutting tool while it is running. It is very dangerous.
- Wear safety glasses, dust mask and use a protective cover around the spindle whenever the spindle is rotating.
- Never connect, disconnect or touch the Power Cord Plug and Motor Cord Connector with wet hands. This may cause an electric shock.
- Never operate or handle the spindle until you have thoroughly read the owner's manual and safe operation has been confirmed.
  - To prevent injuries / damages, check the spindle and cutting tool for proper installation, before operating the spindle.
  - Before disconnecting the spindle, always turn the control power off and turn the compressed air supply to the control unit off. Then it is safe to remove the spindle.
- When installing a tool, tighten the collet chuck correctly and check again the collet chuck before use. Do not over-tighten the collet chuck. This may cause damage to the spindle.
- Do not use bent, broken, chipped, out of round or sub-standard tools as they may cause shatter or explode. Tool with fractures or a bent shank will cause injury to the operator. When using a new tool, rotate it in a low speed and increase speed gradually for safety.
- Do not exceed the maximum recommended allowable tool speed. For your safety, use speeds below the maximum allowable speed.
- Do not apply excessive force. This may cause tool slippage, tool damage, injury to the operator or loss of concentricity and precision.

#### CAUTION

- Do not exceed the maximum allowable motor speed 20,000min<sup>-1</sup>.
- The speed reducer is always used to connect between the air motor AM-300 • AM-310 and this spindle.
- Do not drop or hit this spindle, as shock can damage to the internal components.
- Be sure to clean the collet chuck, the inside of the spindle before replacing the tool. If ground particles or metal chips stick to the inside of spindle or the collet chuck, damage to the collet chuck or spindle can occur due to the loss of precision.
- When cleaning a spindle, stop the motor and remove debris with a soft brush or a cloth. Do not blow air into the spindle with compressed air as foreign particles or cutting debris may get into the ball bearing.
- Always clean the tool shank before installing the tool in the spindle.
- When sizing the correct collet chuck size to the tool shank diameter, a tolerance of +0 ~ -0.01mm is strongly recommended. A tool shank within the +0 ~ -0.1mm range is mountable, however, this may cause poor concentricity and or insufficient tool shank gripping force.
- Select suitable products or tools for all applications. Do not exceed the capabilities of the spindle or tools.
- Carefully direct coolant spray to the tool. Do not spray directly on the spindle body.
- Stop working immediately when abnormal rotation or unusual vibration are observed. Afterwards, please check the content of section " 10. TROUBLESHOOTING ".
- Always check if the tool, collet chuck are damaged before and after operating.
- If the collet chuck show signs of wear or damage, replace it before a malfunction or additional damage occurs.
- After installation, repair, initial operation, or long periods of non operation, please refer to section " 8. BREAK-IN PROCEDURE " detailed in Table 1. When checking the spindle, no vibration or unusual sound should be observed during rotation.
- Do not disassemble, modify or attempt to repair this spindle. Additional damage will occur to the internal components. Service must be performed by NSK NAKANISHI or an authorized service center.
- When using this spindle for mass production, please purchase the another spindle as a spare in case of an emergency.

### 2. FEATURES

- This spindle is ideal for use in applications that are not possible with straight type spindles.
- The spindle housing is made from precision ground, hardened, stainless steel (SUS) with outside mounting diameters of  $\phi 22.8$ mm.
- Various sizes of collet chucks are available CH8 0.8mm - 3.0mm. Standard collet chuck is CH8 3.0mm or CH8 3.175mm. (For U.S. market CH8 3.175mm.)

### 3. SPECIFICATIONS AND DIMENSIONS

#### 3 - 1 Specifications

Model	RA - 100	
Maximum rotating speed at the tool	For Air Motor	2,870min <sup>-1</sup>
	For Electric Motor	7,490min <sup>-1</sup>
Maximum Motor Rotation Speed	For Air Motor	7,650min <sup>-1</sup>
	For Electric Motor	20,000min <sup>-1</sup>
Applicable Motor	For Air Motor	AM - 300R / L, AM - 300RA / LA, AM - 310R / Lm, AM - 310RA / LA
	For Electric Motor	EM25 - 5000 - 4M / 5M / 8M, EM25 - 5000 - J4 / J5 / J8
Reduction Ratio	1 / 2.67	
Standard Collet Chuck (CH8-3.0)	$\phi 3.0$ mm (For U.S. market $\phi 3.175$ mm (CH8 - 3.175))	
Weight	271g	

#### CAUTION

Use less than the maximum allowable motor speed 20,000min<sup>-1</sup>.  
DO NOT exceed the maximum allowable motor speed 20,000min<sup>-1</sup> for the spindle.  
Always use the reducer between the air motor (AM-300 • AM-310) and RA-100.

#### Standard Accessories

- Collet Chuck  $\phi 3.0$ mm (CH8 - 3.0) or  $\phi 3.175$ mm (CH8 - 3.175) • • 1pc.  
(For U.S. market  $\phi 3.175$ mm (CH8-3.175))
- Wrench (7 × 5.5) • • 1 pcs.
- Wrench (20 × 24) • • 1 pc.
- Wrench (8 × 5) • • 1 pcs.
- Operation Manual • • 1 set.

※ The collet chuck is attached to the spindle.

< Option >

Collet Chuck ( CH8-□□ )	$\phi 0.8$ mm ~ $\phi 3.0$ mm in 0.1mm increments and $\phi 2.35$ mm, $\phi 3.175$ mm
Metal Saw Axis (KCH-02)	For $\phi 6$ (I.D.) × $\phi 30$ mm (O.D.)

#### 3 - 2 Outside View

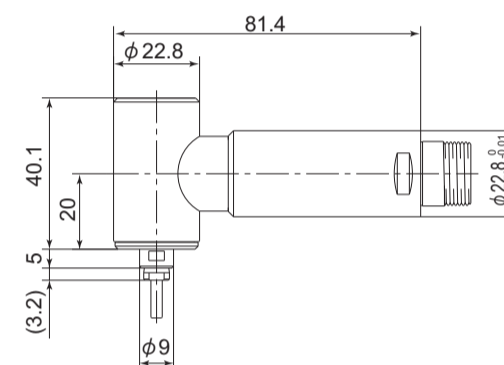

Fig. 1

### 4. CONNECTION TO THE MOTOR

#### CAUTION

Make sure your hands and all interlocking parts of the spindle and motor are clean before connecting the motor to the spindle. This is critical to prevent contaminants from entering the motor or spindle.

Align the threads on the front end of the reducer and the rear end of the spindle, and turn the spindle clockwise. If the drive shaft of the reducer does not engage the drive dog on the spindle, the spindle could not be turned. DO NOT FORCE. Turn the spindle back a few threads, rotate the tool by hand to engage the drive shaft and the drive dog, and make the final turns with provided 20mm wrench. (Fig. 2)

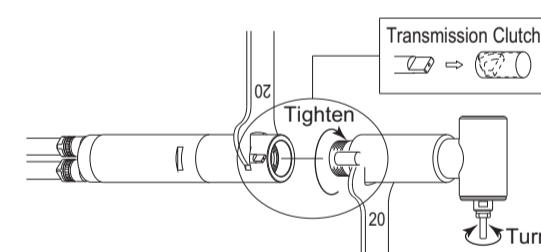

Fig. 2

### 5. CHANGING THE TOOL

#### CAUTION

Do not tighten the collet chuck without inserting a tool or dummy bur as this will result in damage to the collet chuck.

- Set the provided 8mm wrench on the spindle.
- Place the provided 5.5mm wrench on the collet chuck and turn it counterclockwise to loosen the collet chuck and remove the tool.
- Clean the collet chuck, then insert the new tool and tighten the collet chuck by turning clockwise. Do not over-tighten. (Recommended tightening torque : 3N • m)

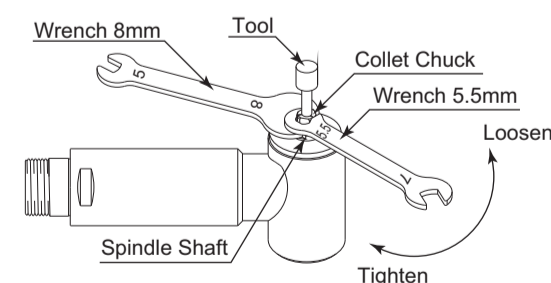

Fig. 3

### 6. REPLACING THE COLLET CHUCK

- Remove the tool according to the section " 5. CHANGING THE TOOL" procedure above. (Fig. 3)
- Place the provided 8mm wrench on the spindle shaft, and turn the top of the collet chuck counterclockwise to remove the collet chuck. (Fig. 4)
- Install the new collet chuck into the spindle by turning it clockwise.

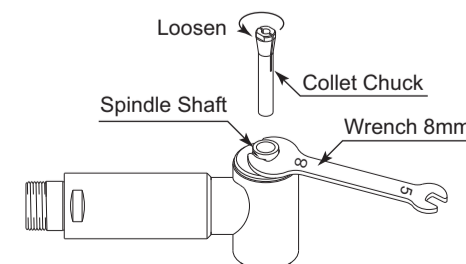

Fig. 4

## 7. INSTALLATION OF THE SPINDLE

### ⚠ WARNING

When installing a spindle to a fixed base, make sure the fixed base is grounded in order to avoid the risk of an electric shock.

### ⚠ CAUTION

- When installing a spindle, do not hit, drop or cause shock to the spindle. This may cause damage to internal components and result in malfunctions.
- When mounting the spindle, be sure to mounting within clamping area etched on the spindle. If the spindle is installed incorrectly, this will cause and damage to the spindle.
- Cautions when tightening the securing bolt of the Split Type Holder  
Do not over-tighten the bolt. This may cause damage to spindle's precision.  
Tighten the bolt until the spindle body can not be turned by hand within the fixture.  
Extreme tightening is not necessary or recommended.  
Apply working force and check that the spindle is tight before using.

- ① When mounting a spindle, refer to the Clamping Area etched on the spindle. (Fig. 5)

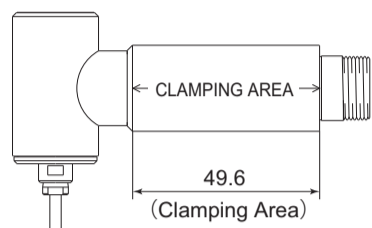

Fig. 5

- ② When installing a spindle to the holder, recommended installation method is shown Fig. 6. Refer to "③ How to fabricate the Split Type Holder". If this is not possible, install as shown in Fig. 7.

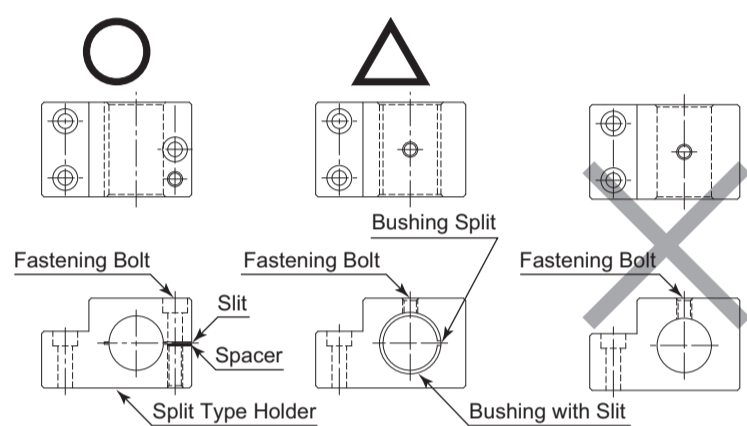

Fig. 6

Fig. 7

Fig. 8

### ⚠ CAUTION

Do not allow set screws to come directly in contact with the spindle body as shown in Fig. 8, as this will result in damage to the spindle housing and internal components.  
When installing, never clamp directly over the bearings, as this will result in bearing damage. (Refer to Fig. 9)

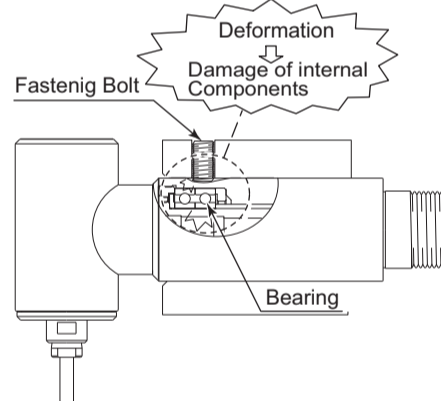

Fig. 9

- ③ How to fabricate the Split Type Holder
- (1) Roughly process (carve) the inside diameter of the Split Type Holder.
  - (2) Cut a slit. (Ex. Slit 2mm)
  - (3) Twist the Screw for Removal and Broaden the Slit Area.
  - (4) Insert spacer (ex t = 2mm) into the Slit Area.
  - (5) Loosen the Screw for Removal, and tighten the fastening bolt with the specified torque.
  - (6) Finish the Split Type Holder so that the inside diameter of the Split Type Holder is  $\phi 22.8$  with its tolerance range from  $-0.01\text{mm}$  to  $-0.015\text{mm}$ , and its roundness and cylindricity of less than  $5\mu\text{m}$ .
  - (7) When inserting the spindle loosen the Fastening Bolt and twist the Screw for Removal, and broaden the Slit Area.

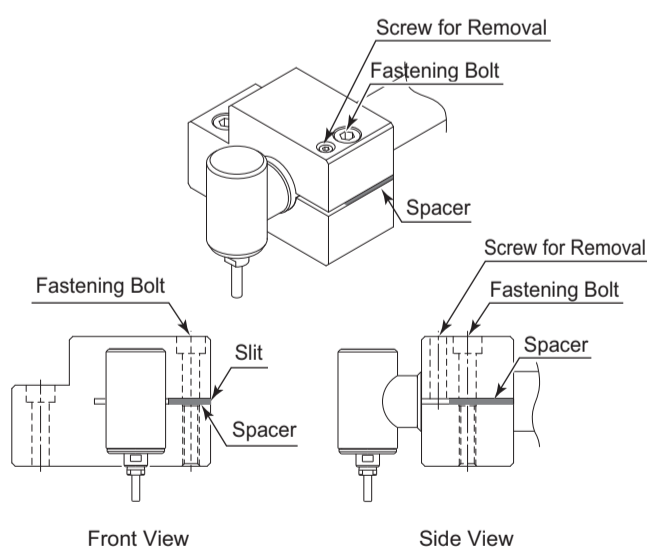

Fig. 10

### ⚠ CAUTION

- How to confirm the tightening standard of the holder by the clamp meter (In case of use a electric motor)  
Measure the current value of the Control Unit's power cord by the clamp meter.  
Fasten the holder so that the increase in the no-load current value (during rotation at the maximum rotation speed) with the spindle fastened is 20mA (for type 100V / 120V) / 10mA (for type 200V / 230V) or less, compared to the no-load current value (during rotation at the maximum rotation speed) without fastening the spindle. Do not over-tighten the Fastening Bolt. It may damage spindle's precision and shorten the life of the bearings.
- The final responsibility for ensuring holder's safety for use in a given application is left to the designer of the equipment in which NAKANISHI's spindle is installed.  
NAKANISHI offers spindles with a wide variety of capabilities and specifications.  
Please carefully check the spindle's specifications against the requirements of your equipment and verify suitability and safety of the Holder prior to initial use.

## 8. BREAK-IN PROCEDURE

During transportation, storage or installation the grease inside the bearings will settle. If the spindle is suddenly run at high-speed excessive heat will cause bearing damage. After installation, repair, initial operation, or long periods of non operation please follow the break-in procedure detailed in Table 1.

Table 1.

Steps		1	2	3	4
Air Pressure (MPa)	For Air Motor	0.1	0.2	0.3	0.4
Rotation Speed (min <sup>-1</sup> )	For Electric Motor	5,000	10,000	15,000	20,000
Rotation Time (min)		15	10	10	15
Items to Check		No Abnormal Noises	The spindle housing temperature during the break-in process should not exceed 20 degrees C (36 degrees F) above ambient temperature. Should the spindle exceed this limit, rest the spindle for at least 20 minutes and re-start the break in procedure from the beginning. If the housing temperature rises again and exceeds 20 degrees C (36 degrees F) above ambient temperature, check the spindle and motor for proper installation.		The spindle housing temperature during the break-in process should not exceed 20 degrees C (36 degrees F) above ambient temperature.

## 9. CAUTIONS WHEN USING GRINDSTONES AND TOOLS

### ⚠ CAUTION

The maximum surface speed or rpm is always specified for a grindstone. Do not exceed the maximum speed with reference to the calculating chart below. Always follow the grindstone manufacturer's recommendations.

$$\text{Surface Speed (m/s)} = \frac{3.14 \times \text{Diameter (mm)} \times \text{rotation speed (min}^{-1}\text{)}}{1,000 \times 60}$$

- ① The proper surface speed for general grindstones is 10-30m/s.
- ② Do not exceed 13mm of overhang for mounted grindstones as shown in Fig. 11. If the overhang must exceed 13mm, reduce the motor speed in accordance with table 2.
- ③ Dress the grindstone prior to use.
- ④ Do not use tools with bent or broken shanks, cracks or excessive run-out.
- ⑤ For grinding, the maximum depth of cut should not exceed 0.01mm radially or axially. Reciprocate the tool several times after each pass to eliminate tool pressure.
- ⑥ Always operate tools within the allowable recommended speed of the tools. Use of a tool outside of the allowable speed of the tools could cause damage to the spindle and injury to the operator.
- ⑦ Keep the tool shank and collet chuck clean. If contaminants are left in the collet chuck or chuck nut, excessive run-out will cause damage to the tool and or spindle.
- ⑧ Do not strike or disassemble the spindle.
- ⑨ Please set the tools to minimize the overhang amount. 13mm is the maximum amount of overhang to maintain high accuracy and safety.

Table 2. Overhang and Speed

Overhang (mm)	Max. Speed (min <sup>-1</sup> )
20	N x 0.5
25	N x 0.3
50	N x 0.1

※ N = Max. Operating Speed with 13mm overhang.

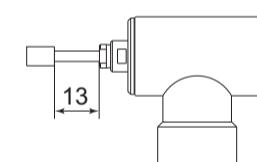

Fig. 11

## 10. TROUBLESHOOTING

If a problem or concern occurs, please check the following prior to consulting your dealer.

Trouble	Cause	Inspection / Corrective Action
Spindle does not rotate or rotate smoothly.	The spindles bearings have been damaged.	Replace the ball bearings. (Return to NAKANISHI dealer service.)
	The motor has been damaged.	Replace the motor. (Return to NAKANISHI dealer service.)
Overheating during rotation.	Cutting debris has contaminated the ball bearings, and the ball bearings are damaged.	Replace the ball bearings. (Return to NAKANISHI dealer service.)
	Low air pressure.	Check air hose connection and air pressure.
Abnormal vibration or noise during rotation.	The tool shank is bent.	Replace the tool.
	Cutting debris has contaminated the ball bearing.	Replace the ball bearings. (Return to NAKANISHI dealer service.)
	The spindles bearings have been damaged.	Replace the ball bearings. (Return to NAKANISHI dealer service.)
Tool slippage.	Collet chuck is not correctly installed.	Check and clean the collet chuck. Reinstall the collet chuck.
	The collet chuck is worn.	Replace the collet chuck.
High run-out.	The tool is bent.	Change the tool.
	Collet chuck is not correctly installed.	Secure the collet chuck correctly.
	The collet chuck is worn.	Replace the collet chuck.
	Inside of the spindle is worn.	Replace the spindle shaft. (Return to NAKANISHI dealer service.)
	Contaminants inside the collet chuck or the spindle.	Clean the collet chuc and the inside of the taper and spindle.
	The ball bearings are worn.	Replace the ball bearings. (Return to NAKANISHI dealer service.)