



MAFRA
 MAILE GMBH
 PRÄZISIONSMASCHINEN
 WWW.MAFRA.DE · INFO@MAFRA.DE

MICRO GRINDERS



MICRO GRINDERS



MAFRA
 MAILE GMBH
 PRÄZISIONSMASCHINEN
 WWW.MAFRA.DE · INFO@MAFRA.DE

NAKANISHI INC.

Headquarters · Factory
 700 Shimohinata, Kanuma, Tochigi 322-8666, Japan
 TEL:+81-289-64-3520/FAX:+81-289-62-1135

※Specifications and design are subject to change without notice.

www.nakanishi-inc.com
 PR-K376E Ver.1 2022-06-14 05. 1110

NAKANISHI INC. 2022

Our product lines to meet your needs.

Since its establishment in 1930, NAKANISHI's philosophy of manufacturing has been to provide products that are "robust, elegant, yet reasonably priced."

In 1982, NAKANISHI entered the general industrial field by applying the high-speed rotary technology cultivated in the dental field.

NAKANISHI's first product was a hand-operated precision Micro Grinder. Micro Grinders are used in a wide variety of industries that require precision and accuracy in their work.

We support the manufacturing of products that provide convenience and affluence to people's day-to-day lives.



Headquarters



Headquarters: Center Court



Factory A1

1. Electric System Products



Attachment Type Brushless Micro-Grinder

Emax EVOLUTION

p.1-3~



Attachment Type High Torque Brushless Micro-Grinder

Espert 500

p.1-21~

2. Air System Products



Attachment Type Micro Air Grinder

ROTUS

p.2-3~



Pencil Type Air Grinder

IMPULSE

p.2-11~



Ultra-High Speed Air Turbine Grinder

PRESTO II

p.2-18~

3. Ultrasonic System Products



Ultrasonic Polisher

Sheenus ZERO

p.3-3~



Ultrasonic Cutter

Sonic Cutter ZERO

p.3-7~

4. General Parts・Protective Equipments p.4-3~

5. Exclusive Tools p.5-1~



Symbols used in
NAKANISHI Exclusive Tools

Tools for "Sheenus ZERO"

Tools for "LUSTER"



Tools for "MINI-LUSTER" "SWING-LUSTER"

Tools for "ANGLE TYPE" "MINI-ANGLE TYPE"

Tools for "FINE BELT SANDER"

CAUTION

Electric System

Air System

Ultrasonic

General Parts

Exclusive Tools

For safe usage

- Please read operation manuals before using any NAKANISHI product.
- Please keep the operation manuals on hand so that the user can refer to them at any time.

⚠ Caution

Incorrect use of the product, or ignoring 'CAUTIONS for safety' described in the operating manuals may cause fatal or serious bodily injury.

CAUTIONS

	Always use safety glasses, masks, face guards for your safety.		Select proper hand tools and for your application. Select tools carefully considering the performance of the hand tools, work procedure and type / shape of the material.
	Do not touch the tools and hand tools when in operation. Make sure the work area is neat and there is sufficient light.		Do not wear loose clothing and/or accessories that may be caught in machinery. Long hair should be tied prior to machine operation.
	Do not operate the products where flammable liquids or gases exist.		Fix the work material firmly in a vise and/or other clamping fixture.
	Do not leave the work area with the hand tools still in operation. Confirm that the hand tools have completely stopped after switching them off.		Perform an inspection before use. Clean the inside of the collet and tool shank, chips or fine metals inside the collet could cause tool slippage and result in damage to machinery or bodily injury.

	Fasten the chuck firmly. Make sure the tool is intact in the chuck to avoid tool slippage.		Do not apply high pressure or pry to the tools. This can break and/or bend the tools. Use the tools within their design limitation. Excessive pressure will decrease the efficiency of your work and cause excessive wear of the tools.										
	Do not use damaged or broken electric cords and air hoses.		Check the tools carefully before use. Confirm that the tools are free of chips, cracks, splits, scratches, lack of bonding, deformation, etc.										
	Start at low speed and gradually increase to insure safe work. This is particularly important for the use of new tools, large cutting tools and elastic tools such as rubber grindstone, sander and brush tools.		Stop grinding or polishing immediately whenever unusual sounds, vibrations, or wear are found. Restart the work only after the problem is solved.										
	Store the tools and hand tools in a cool and dry place.		Only use attachments, parts, consumable articles and accessories produced by NAKANISHI INC.										
	The tools should be used by taking care of the overhang and below maximum allowable speed. The catalogue shows the maximum allowable speed at 10 mm overhang (distance between the face of the collet and the top of the tool shank).	<p>Decrease the speed as shown in the table below, if you are using a longer overhang than 10 mm.</p> <table border="1"> <thead> <tr> <th>Overhang</th> <th>Maximum allowable speed (min⁻¹)</th> </tr> </thead> <tbody> <tr> <td>Less than 10 mm</td> <td>Shown in the catalogue (A)</td> </tr> <tr> <td>Less than 20 mm</td> <td>(A) x 0.5</td> </tr> <tr> <td>Less than 25 mm</td> <td>(A) x 0.3</td> </tr> <tr> <td>Less than 50 mm</td> <td>(A) x 0.1</td> </tr> </tbody> </table>		Overhang	Maximum allowable speed (min ⁻¹)	Less than 10 mm	Shown in the catalogue (A)	Less than 20 mm	(A) x 0.5	Less than 25 mm	(A) x 0.3	Less than 50 mm	(A) x 0.1
Overhang	Maximum allowable speed (min ⁻¹)												
Less than 10 mm	Shown in the catalogue (A)												
Less than 20 mm	(A) x 0.5												
Less than 25 mm	(A) x 0.3												
Less than 50 mm	(A) x 0.1												

Electric System Products

INDEX

▶▶▶ Emax *EVO*lution Series

- Standard Sets p.1-5
- Examples of Applications p.1-6
- Controllers p.1-7
- Brushless Motors p.1-8
- System Chart p.1-9~10
- Micro Grinders p.1-11~12
- Angle Grinders p.1-13~14
- Pencil Type Reciprocating Polishing Finisher p.1-15~16
- Fine Belt Sander p.1-17
- Pistol Type Polisher p.1-18
- Attachments p.1-19
- Joints / Foot Controllers / Torque Sets p.1-20



Attachment Type
Brushless Micro-Grinder
1,000~40,000 min⁻¹

▶▶▶ *Esper*t 500 Series

- Features p.1-21~23
- Controllers p.1-24
- Set Products p.1-25
- Motor handpieces p.1-26
- System Chart p.1-27
- Controllers / Brushless Motors p.1-28
- Attachments p.1-29~31
- Parts p.1-32



Attachment Type High Torque
Brushless Micro-Grinder
1,000~50,000 min⁻¹

CAUTION

CAUTION

Electric System

Electric System

Air System

Air System

Ultrasonic

Ultrasonic

General Parts

General Parts

Exclusive Tools

Exclusive Tools



Emax EVolution

ULTRA-PRECISION BRUSHLESS MICRO-GRINDER



CAUTION

Electric System

Air System

Ultrasonic

General Parts

Exclusive Tools

CAUTION

Electric System

Air System

Ultrasonic

General Parts

Exclusive Tools

ADVANCED HIGH PERFORMANCE BRUSHLESS MICRO-GRINDER

Emax **EVolution Series**

Emax **EVolution SERIES** ◀◀

“Powerful Torque”

“Easy to Recognize Live Load Indicator”

“No need to replace carbon brushes”
(Brushless motor)



1,000~40,000 min⁻¹

Emax **EVolution Standard Set**

Code No.	8233 (120V)	Model	EV410-120
Code No.	8225 (230V)	Model	EV410-230

※ Please check the power source plug type (p.4-6).

Standard Equipment

- Micro Grinder (IR-310+ENK-410S) : 1 pc.
- Collet ø3.0 mm (CHH-3.0), ø2.35 mm (CHH-2.35) : 1 pc. each
- Controller (NE249) : 1 pc.
- Accessories : Handpiece Holder : 1 pc., Handpiece Stand : 1 pc.
Power Supply Cord : 1 pc., Wrench (7 x 5.1) : 1 pc.
Pin Wrench (K-233) : 2 pcs., L Shaped Wrench (9) : 1 pc.

※ Torque set → p.1-20



Example of Applications



Tool : Electroplated Diamond Burs



Tool : Diamond Grinding Discs



Tool : Flap Wheels



Tool : Abrasive Belts → p.5-32



Tool : Sand Paper Disk → p.5-25~26



Tool : Felt Bobs

CAUTION

Electric System

Air System

Ultrasonic

General Parts

Exclusive Tools

CAUTION

Electric System

Air System

Ultrasonic

General Parts

Exclusive Tools

ADVANCED HIGH PERFORMANCE CONTROLLER

Emax EVolution Controller

Advanced Control Function

Upgraded Digital Display. EVOLUTION on Speed Control Volume with easy to recognize Load Indicator.



Motor speed digital display

Load Meter

- Continuous load area
- Intermittent load area
- Overload

Forward / Reverse Select Switch
Forward / Reverse rotation can be selected.

ø12mm Speed Control Volume
Easy to operate by one finger

Motor A
ON / OFF Function

Emax EVolution Controller

Code No.	8224 (120V)	Model	NE249 120
Code No.	8227 (230V)	Model	NE249 230

Specifications

Description	Emax EVolution Controller
Power Source	AC120/230V, 50-60Hz
Dimensions	W130 x D254 x H97 mm
Weight	2.3 kg

Accessories : Handpiece Holder : 1 pc., Handpiece Stand : 1 pc.
Power Supply Cord : 1 pc.

⚠ Never connect to E-max Series motor.
※ Please check the power source plug type (p.4-6).

Memory Speed Function FiXspeed®

A new feature is the "FiXspeed®" function, which allows the user to memorize RPMs in advance. The frequently used speed can be set at the touch of a button regardless of the volume position. Furthermore, A and B can be set independently, so A can be controlled by FiXspeed and B can be controlled variably with a foot controller to help improve work efficiency.

Auto Cruise Function

An Auto Cruise function is provided to fix the rpm at a fixed speed while working with the foot controller. This function allows the operator to work without using the foot controller when continuously performing the same task, thus reducing foot fatigue.



Memory Speed Function FiXspeed®

Motor B
ON / OFF Function

Diversity for work efficiency

2 Sets of motors can be connected at the same time, to further improve work efficiency. (The motors cannot be used simultaneously)



Advanced User Friendly Design

Integrated handle for carrying. The design ensures ease of use by allowing the handpiece and tools to be placed on the top.



ADVANCED HIGH PERFORMANCE BRUSHLESS MOTOR

Emax EVolution Motor

Excellent Durability

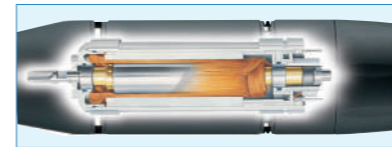

- High performance brushless motor eliminates the need of changing carbon brushes.
- RPM variation is minimal even when load changes. Allowing difficult and stable cutting in stress free motion. Suitable performance for finish grinding.
- Provides superior quietness and smoothness from low speed to high speed.

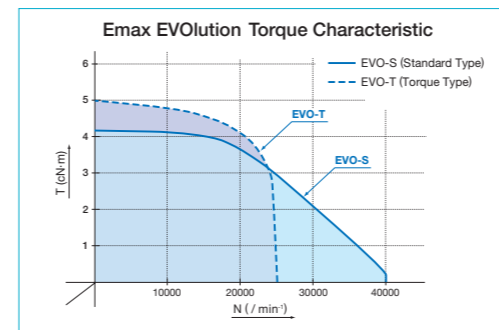

2 Types of Motors

Provides choice of various applications.

- Standard Type Motor 1,000~40,000 min⁻¹ (ENK-410S) Blue
- Torque Type Motor 1,000~25,000 min⁻¹ (ENK-250T) Green

※ Exclusive use for Emax EVolution

NAKANISHI Smart Switch

The switch provides a click sensation. A confirmation tone is reacted by the controller when the switch is operated. The motor type is distinguishable by the switch color.



Standard Type Motor

Code No.	8086
Model	ENK-410S

1,000~40,000 min⁻¹

• Excellent combination of high speed, lightweight, small diameter and high torque. This lightweight and compact general-use type is perfect for precision work.

- ◆ Max. Power : 73 W
- ◆ Max. Torque : 4.3 cN·m
- ◆ With Straight Cord : 1.5 m
- ◆ Weight : 90 g (w/o cord)

Standard Accessories
• Pin Wrench (K-233) : 1 pc.

⚠ Never connect to E-max Series controller.



Torque Type Motor

Code No.	8087
Model	ENK-250T

1,000~25,000 min⁻¹

• Combines the best of both high speed and high torque. It is perfect for applications requiring large burs.

- ◆ Max. Power : 76 W
- ◆ Max. Torque : 4.8 cN·m
- ◆ With Straight Cord : 1.5 m
- ◆ Weight : 147 g (w/o cord)

⚠ Never connect to E-max Series controller.



Code No.	Model
----------	-------

Attachment

※Compatible with attachments from E-max and ROTUS system.

1147	IR-310
------	--------



Ring Type

1005	IH-300
------	--------



Lever Type

1016	HG-200
------	--------



6 mm Torque Type¹

1017	BMH-300
------	---------



Long Type

1012	MFC-300S
------	----------



90° Mini Angle Type

1013	MFC-300M
------	----------



90° Mini Angle Type (Very Small Head)

1006	IC-300
------	--------



90° Angle Type

1014	KC-300
------	--------



50° Angle Type

LUSTER	1302	LS-100
--------	------	--------

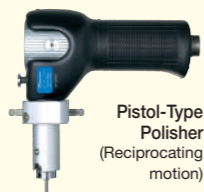

Pistol-Type Polisher (Reciprocating motion)

MINI-LUSTER	1307	ML-8
-------------	------	------



Pencil-Type Reciprocating Polishing Finisher (Reciprocating motion)

SWING-LUSTER	1380	SLS-16
--------------	------	--------



Pencil-Type Reciprocating Polishing Finisher (Right to Left motion)

Hammer Action Type	8060	HA-500
--------------------	------	--------



Engraving and Ornament Processing Work Hammer

FINE BELT SANDER	1146	KBS-101
------------------	------	---------



Small-sized Handy Belt Sander



Pistol-Type Polisher (Reciprocating motion) Built-in Motor

LUSTER	1483	NLS-110
--------	------	---------

Exclusive use for Emax EVOLUTION

- Wide selection of attachments available depending on the application.

Speed Reducer·Extension Joint



Extension Joint	1015	CN-01
-----------------	------	-------



1/4 Speed Reducer	1009	RG-01
-------------------	------	-------



1/15 Speed Reducer	1010	RG-02
--------------------	------	-------

※ Can be connected between the motor and the attachment when a higher level of torque is required.

Motor

Emax EVolution Series



• Standard Type Motor with Cord	8086	ENK-410S	1,000-40,000 min ⁻¹
---------------------------------	------	----------	--------------------------------



• Torque Type Motor with Cord	8087	ENK-250T	1,000-25,000 min ⁻¹
-------------------------------	------	----------	--------------------------------

Exclusive use for Emax EVOLUTION

ROTUS Series



• Air Motor with Hose 360° Twist-Free Joint Mechanism	1004	IM-301	3,000-30,000 min ⁻¹
---	------	--------	--------------------------------

Controller

Emax EVolution



8224 (120V)	NE249 120
8227 (230V)	NE249 230

• Foot Controller



8106	FC-64
------	-------

Sets



Emax EVolution Standard Set

Code No.	Model
8233 (120V)	EV410-120
8225 (230V)	EV410-230

Standard Equipment

- Micro Grinder (IR-310+ENK-410S) : 1 pc.
- Collet ø3.0 mm (CHH-3.0), ø2.35 mm (CHH-2.35) : 1 pc. each
- Controller (NE249) : 1 pc.
- Accessories : Handpiece Holder : 1 pc. Handpiece Stand : 1 pc. Power Supply Cord : 1 pc. Wrench (7 x 5.1) : 1 pc. Pin Wrench (K-233) : 2 pcs. L Shaped Wrench (9) : 1 pc.

Electric System

Air System

• Air Line Kit



4507	AL-H1207F
------	-----------

• Foot Controller



1064	AFC-45
------	--------

※This Air Line Kit is designed for use with the AFC-45 Foot Controller, Code No.1064.



ROTUS Standard Set

Code No.	Model
1163	ROTUS-IR

Standard Equipment

- Air Grinder (IR-310+IM-301) : 1 pc.
- Collet ø3.0mm (CHH-3.0), ø2.35 mm (CHH-2.35) : 1 pc. each
- Air Line Kit (AL-H1207F) : 1 pc.
- Foot Controller (AFC-45) : 1 pc.
- Accessories : Piping Hose 2m (K-275) : 1 pc. Lubricating Oil (K-211) : 1 pc. Wrench (7 x 5.1) : 1 pc. Pin Wrench (K-233) : 2 pcs. L Shaped Wrench (9) : 1 pc.

<Caution>

※1 : Use 6 mm Torque Type ENK-250T to connect HG-200

⚠ Details of Maximum Allowable speed on intermittent use or continuous use p.1-11-20

RING TYPE MICRO-GRINDER ◀◀

PRECISION MICRO-GRINDER

Ring Type Attachment

Ring Type Chucking System

- One-touch ring type bur replacement.
- High precision and high reliability is realized by micron grade precision.
- Slim, lightweight design allows fine finishing on delicate parts.

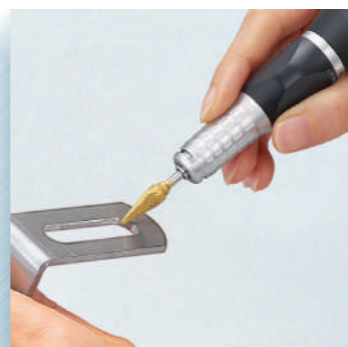

40,000 min⁻¹ Max.

◆ Weight : 92 g

Standard Size Collet

ø3.0 mm (CHH-3.0) ø2.35 mm (CHH-2.35)

Optional Collets : CHH Group are shown in page (p.4-3)

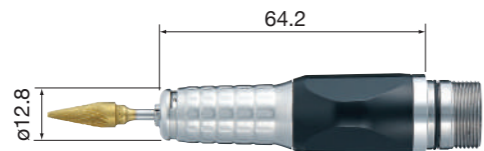

Code No. **1147** Model **IR-310**

Standard Accessories

- Wrench (7 x 5.1) : 1 pc. • Pin Wrench (K-233) : 1 pc.
- L Shaped Wrench (9) : 1 pc.

LONG TYPE MICRO-GRINDER ◀◀

PRECISION MICRO-GRINDER

Long Type Attachment

Tip diameter ø13 mm

- This unique slim body makes it ideal for cutting and grinding the bottom surface of deep ribs or holes.
- Collet is tightened by a wrench.
- The tip diameter is ø13 mm.



35,000 min⁻¹ Max.

◆ Weight : 156 g

Standard Size Collet

ø3.0 mm (CHM-3.0)

Optional Collets : CHM Group are shown in page (p.4-4)

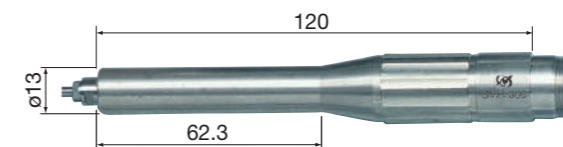

Code No. **1017** Model **BMH-300**

Standard Accessories

- Wrench (7 x 5.1), (6 x 4.5) : 1 pc. each
- Pin Wrench (K-233) : 1 pc.

Ring Type Attachment + Standard Type Motor Combination Example

1,000~40,000 min⁻¹

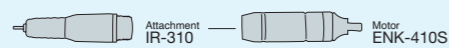

Long Type Attachment + Standard Type Motor Combination Example

1,000~35,000 min⁻¹

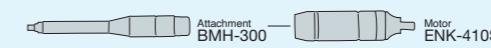

Ring Type Attachment + Torque Type Motor Combination Example

1,000~25,000 min⁻¹

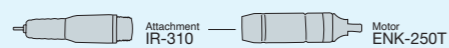

Emax EVolution Controller (p.1-7)
 <Code No. : 8224 (120V) · Model : NE249 120>
 <Code No. : 8227 (230V) · Model : NE249 230>

⚠ Never connect to E-max Series Controller.

Combination Example	d	D	l 1	l 2	L	Weight	Max. Torque	Speed Range	Collet
1147+8086	ø12.8	ø24.5	64.2	97	161.2	182 g (※)	4.3 cN·m	1,000~40,000 min ⁻¹	ø0.3~ø3.175 mm CHH Group (p.4-3)
1147+8087	ø12.8	ø28.4	64.2	108	172.2	239 g (※)	4.8 cN·m	1,000~25,000 min ⁻¹	ø0.3~ø3.175 mm CHH Group (p.4-3)

※ Weight (w/o Straight Cord)

Emax EVolution Controller (p.1-7)
 <Code No. : 8224 (120V) · Model : NE249 120>
 <Code No. : 8227 (230V) · Model : NE249 230>

⚠ Never connect to E-max Series Controller.

Combination Example	Outside Diameter	Weight	Max. Torque	Speed Range	Collet
1017+8086	Refer to the dimensions	246 g (※)	4.3 cN·m	1,000~35,000 min ⁻¹	ø0.3~ø3.175 mm CHM Group (p.4-4)

※ Weight (w/o Straight Cord)

CAUTION

Electric System

Air System

Ultrasonic

General Parts

Exclusive Tools

CAUTION

Electric System

Air System

Ultrasonic

General Parts

Exclusive Tools

MINI ANGLE TYPE MICRO-GRINDER ◀◀

ANGLE TYPE GRINDER

Mini Angle Type Attachment

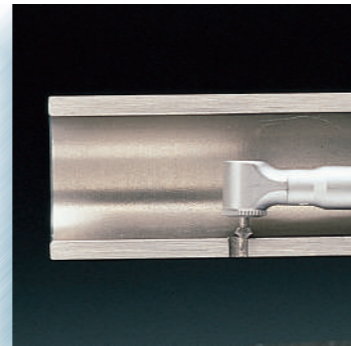

For Chamfering Deep Hole | Bur Only $\phi 1.6$ mm | Exclusive Tools p.5-31

- Suitable for chamfering and deburring the inside of the slit pipe.
- The smallest angle type attachment in NAKANISHI's lineup.
- Various $\phi 1.6$ mm exclusive tools are available.

15,000 min⁻¹ Max.

- ◆ Minimum Inner Diameter : $\phi 13$ mm
- ◆ Holding tool width : 7.2 mm ◆ Weight : 47 g
- ◆ Speed Reduction Ratio : 10/11

Standard Size Collet $\phi 1.6$ mm (K-253) p.4-4 | Exclusive Tools p.5-31

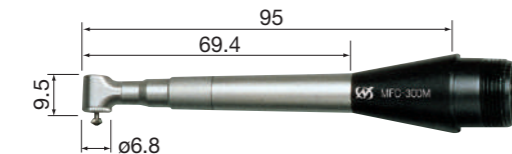

Mini Angle Type (Very Small Head)

Code No. **1013** Model **MFC-300M**

Standard Accessories
• Collet Wrench (K-232) : 1 pc. • Pin Wrench (K-233) : 1 pc.

Mini Angle Type

Code No. **1012** Model **MFC-300S**

Standard Accessories
• Collet Wrench (K-232) : 1 pc. • Pin Wrench (K-233) : 1 pc.

- ◆ Minimum Inner Diameter : $\phi 20$ mm
- ◆ Holding tool width : 11.9 mm ◆ Weight : 50 g
- ◆ Speed Reduction Ratio : 10/11

Standard Size Collet $\phi 1.6$ mm (K-252) p.4-4 | Exclusive Tools p.5-31

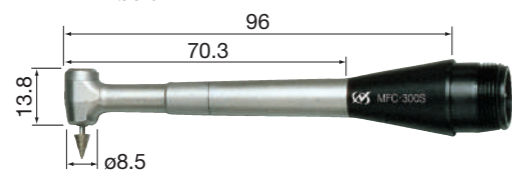

Mini Angle Type Attachment + Standard Type Motor Combination Example

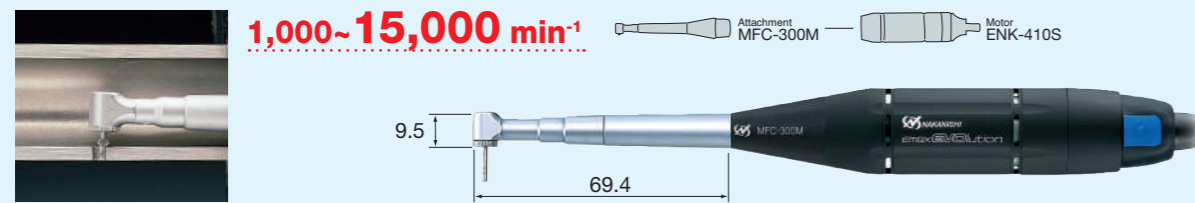

Mini Angle Type Attachment + Standard Type Motor Combination Example

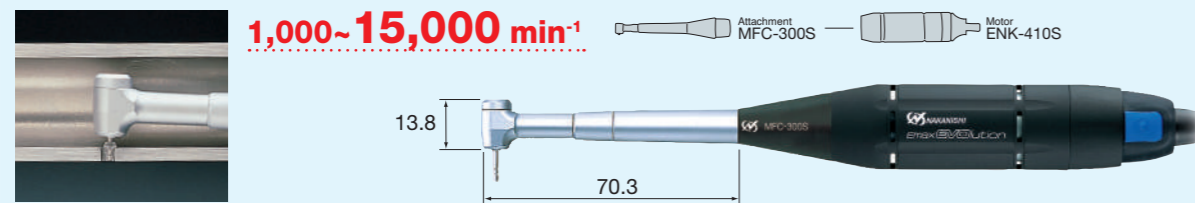

Emax EVolution Controller (p.1-7)
 <Code No. : 8224 (120V) · Model : NE249 120>
 <Code No. : 8227 (230V) · Model : NE249 230>

⚠ Never connect to E-max Series Controller.

Combination Example	d	D	l 1	l 2	L	Weight	Max. Torque	Speed Range	Collet
1013+8086	$\phi 6.8$	$\phi 24.5$	95	97	192	137 g (≒)	4.3 cN·m	1,000~15,000 min ⁻¹	$\phi 1.6$ mm (K-253) (p.4-4)
1012+8086	$\phi 8.5$	$\phi 24.5$	96	97	193	140 g (≒)	4.3 cN·m	1,000~15,000 min ⁻¹	$\phi 1.6$ mm (K-252) (p.4-4)

※ Weight (w/o Straight Cord)

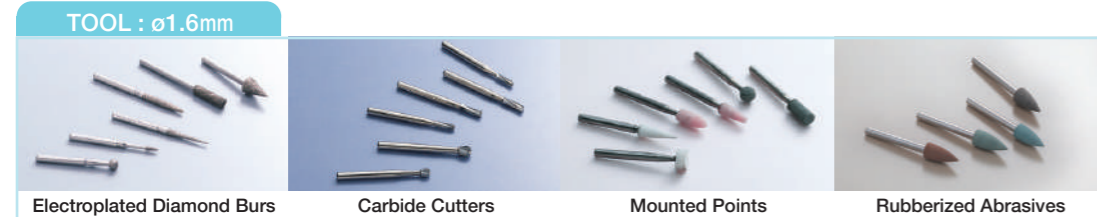

ANGLE TYPE MICRO-GRINDER ◀◀

ANGLE TYPE GRINDER

Angle Type Attachment

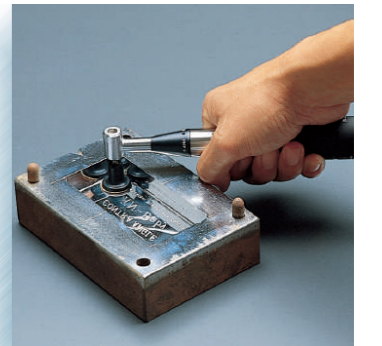

Most suitable for polishing flat surfaces at speed | Exclusive Tools p.5-25~30

- Suitable for grinding and polishing process with shaft mounted tools.
- Perfect for finishing bottom surfaces and other tight, hard to reach areas.

30,000 min⁻¹ Max.

- ◆ Weight : 45 g
- ◆ Speed Reduction Ratio : 3/4

Standard Size Collet $\phi 3.0$ mm (CHC-3.0) | Exclusive Tools p.5-25~30

Optional Collets : CHC Group are shown in page (p.4-3)

- ◆ Weight : 45 g
- ◆ Speed Reduction Ratio : 3/4
- Use the motor in reverse rotation for clockwise rotation.

Standard Size Collet $\phi 3.0$ mm (CHC-3.0) | Exclusive Tools p.5-25~30

Optional Collets : CHC Group are shown in page (p.4-3)

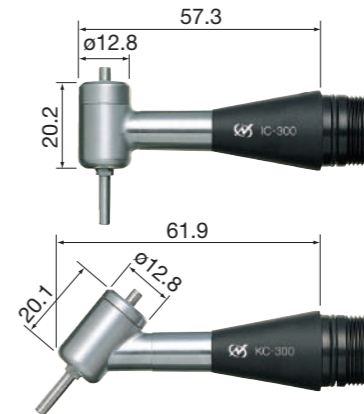

Angle Type (90°)

Code No. **1006** Model **IC-300**

Standard Accessories
• Collet Wrench (K-231) : 1 pc. • Pin Wrench (K-233) : 1 pc.
• Standard Accessories : 1 set

Angle Type (50°)

Code No. **1014** Model **KC-300**

Standard Accessories
• Collet Wrench (K-231) : 1 pc. • Pin Wrench (K-233) : 1 pc.
• Standard Accessories : 1 set

90° Angle Type Attachment + Standard Type Motor Combination Example

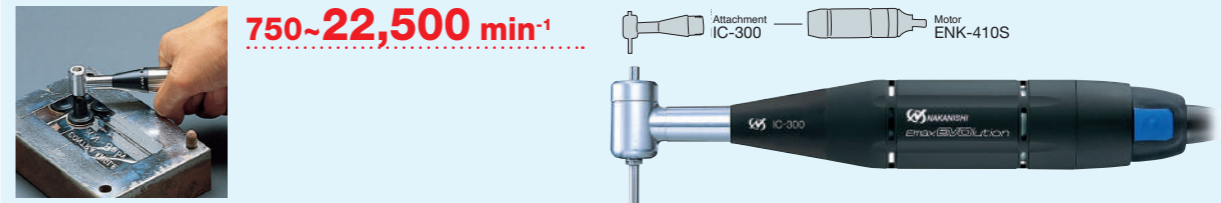

50° Angle Type Attachment + Standard Type Motor Combination Example

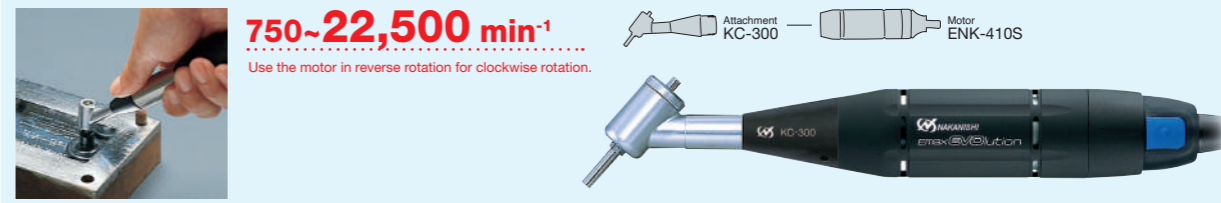

Emax EVolution Controller (p.1-7)
 <Code No. : 8224 (120V) · Model : NE249 120>
 <Code No. : 8227 (230V) · Model : NE249 230>

⚠ Never connect to E-max Series Controller.

Combination Example	d	D	l 1	l 2	L	Weight	Max. Torque	Speed Range	Collet
1006+8086	20.2	$\phi 24.5$	57.3	97	154.3	135 g (≒)	4.3 cN·m	750~22,500 min ⁻¹	$\phi 1.0$ ~ $\phi 3.175$ mm
1014+8086	20.1	$\phi 24.5$	61.9	97	158.9	135 g (≒)	4.3 cN·m	750~22,500 min ⁻¹	CHC Group (p.4-3)

※ Weight (w/o Straight Cord)

Code No.	Description	Package
64101	Rubber Pad (Small) O.D. $\phi 10$ mm	1 pc./pack
64102	Rubber Pad (Med) O.D. $\phi 20$ mm	
64103	Rubber Pad (Large) O.D. $\phi 30$ mm	
64203	Sand Paper Disk for small pad $\phi 11$ #180	5 pcs./pack
64223	Sand Paper Disk for large pad $\phi 31$ #180	
64227	Sand Paper Disk for large pad $\phi 31$ #600	

• Exclusive tools for Angle Type Attachment p.5-25~30

MINI-LUSTER ◀◀

PENCIL-TYPE RECIPROCATING POLISHING FINISHER

MINI-LUSTER Attachment

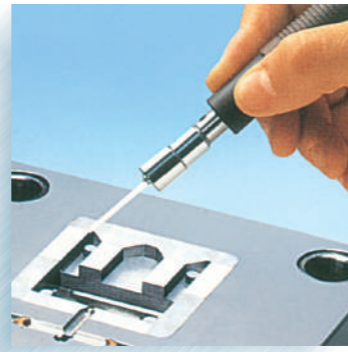

Stroke Range 0.8 mm Reciprocating Motion Exclusive Tools p.5-19~22

- The pencil type grip is most suitable for polishing narrow grooves, details, etc.
- Lightweight, compact design and minimal vibration helps keep the hand free from fatigue for long continuous operation.
- By using the provided grindstone holder, various tools such as oil stones, super stones, diamond files, etc. can be used.

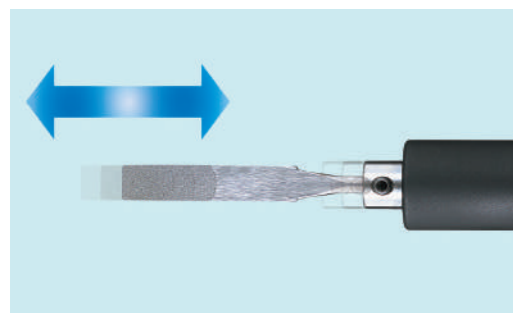

25,000 min⁻¹ Max.
 ◆ Stroke Range (Fixed) : 0.8 mm
 ◆ Reciprocating Stroke (Variable) : 0~6,380 times/min
 ◆ Weight : 130 g
 ◆ Max. tool shank diameter ø3.5 mm, Screw clamp type

Exclusive Tools p.5-19~22

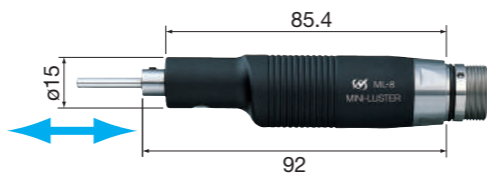

Code No. **1307** Model **ML-8** Stroke (0.8 mm)

Standard Accessories
 • Allen Wrench (1.5 mm) : 1 pc.
 • Standard Accessories : 1 set

SWING-LUSTER ◀◀

PENCIL-TYPE RECIPROCATING POLISHING FINISHER

SWING-LUSTER Attachment



Stroke Range 0~1.6 mm Right to Left Motion Exclusive Tools p.5-23~24

- High speed grinding and polishing operations can be performed while maintaining the fine and delicate feel of hand polishing.
- Lightweight pencil type design makes it easy to work in tight areas.
- Ergonomically designed to provide high sensitivity for precision work.
- Easily adjustable stroke length allows efficient work on minute areas of large sections.

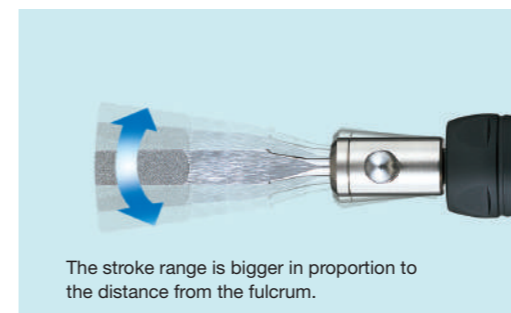

30,000 min⁻¹ Max.
 ◆ Reciprocating Stroke (variable) : 0~7,650 times/min
 ◆ Stroke Range (variable) : 0~1.6 mm
 ◆ Weight : 127 g
 ◆ Max. tool shank diameter ø5.0 mm, Screw clamp type

Exclusive Tools p.5-23~24



Code No. **1380** Model **SLS-16**

Standard Accessories
 • Wrench (16 x 18), (20 x 24) : 1 pc. each
 • Allen Wrench (1.5 mm) : 1 pc.
 • Standard Accessories : 1 set

MINI-LUSTER Attachment + Standard Type Motor Combination Example

Reciprocating Stroke
0~6,380 times/min

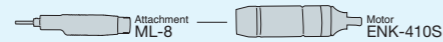

SWING-LUSTER Attachment + Standard Type Motor Combination Example

Reciprocating Stroke
0~7,650 times/min

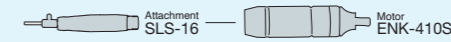



Emax EVolution Controller (p.1-7)
 <Code No. : 8224 (120V) · Model : NE249 120>
 <Code No. : 8227 (230V) · Model : NE249 230>

⚠ Never connect to E-max Series Controller.



Combination Example	Outside Diameter	Weight	Max. Torque	Reciprocating Stroke	Max. Tool Shank
1307+8086	Refer to the dimensions	220 g (※)	4.3 cN·m	0~6,380 times/min	ø3.5 mm (screw clamp type)

Standard Accessories

Code No.	Description	Package
62751	Spring Holder	1 pc. each
62510	Ceramic Fiber Grindstone Holder	
62814	Electroplated Diamond File 1.25 x 4 x 50 #100	
60520	Ceramic Fiber Grindstone 1 x 6 x 50 #1200	

• Exclusive tools p.5-19~22

※ Weight (w/o Straight Cord)



Emax EVolution Controller (p.1-7)
 <Code No. : 8224 (120V) · Model : NE249 120>
 <Code No. : 8227 (230V) · Model : NE249 230>

⚠ Never connect to E-max Series Controller.



Combination Example	Outside Diameter	Weight	Max. Torque	Reciprocating Stroke	Max. Tool Shank
1380+8086	Refer to the dimensions	217 g (※)	4.3 cN·m	0~7,650 times/min	ø5.0 mm (screw clamp type)

Standard Accessories

Code No.	Description	Package
62510	Ceramic Fiber Grindstone Holder	1 pc. each
62814	Electroplated Diamond File 1.25 x 4 x 50 #100	
60520	Ceramic Fiber Grindstone 1 x 6 x 50 #1200	

• Exclusive tools p.5-23~24

※ Weight (w/o Straight Cord)

FINE BELT SANDER ◀◀

SMALL-SIZED HANDY BELT SANDER

FINE BELT SANDER Attachment



Exclusive Tools p.5-32

- Very high belt speed, ideal for applications from deburring to finishing.
- Belt runs Approx. 0~705 m/min
- Lightweight, compact, minimal vibration and a small diameter grip design helps keep the hand free from fatigue for long, continuous operation.
- The angle of the belt section is fully adjustable.
- The belt can be changed easily with the lever release.
- 4, 6, 8 mm width belts are available.

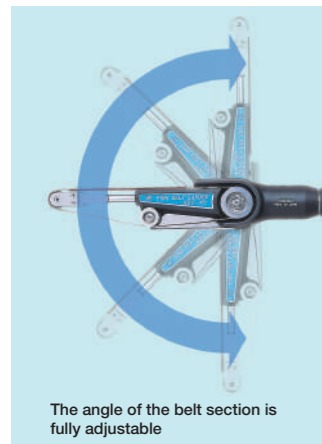

30,000 min⁻¹ Max.
 ◆ Belt Speed : 0~705 m/min
 ◆ Weight : 350 g ◆ Belt Sizes : 4, 6, 8 mm Wide × 300 mm long

Exclusive Tools p.5-32

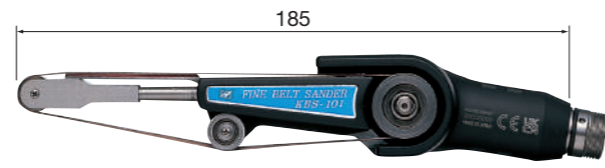

Code No. **1146** Model **KBS-101**

Standard Accessories
 • Allen Wrench (3 mm) : 1 pc. • Standard Accessories : 1 set

FINE BELT SANDER Attachment + Standard Type Motor Combination Example

0~705 m/min

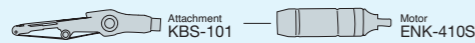

Emax EVolution Controller (p.1-7)
 <Code No. : 8224 (120V) · Model : NE249 120>
 <Code No. : 8227 (230V) · Model : NE249 230>

⚠ Never connect to E-max Series Controller.

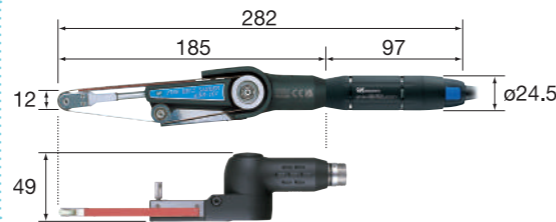

Combination Example	Outside Diameter	Weight	Max. Torque	Belt Speed	Belt Width
1146+8086	Refer to the dimensions	440 g (※)	4.3 cN·m	0~705 m/min	4 mm, 6 mm, 8 mm

※ Weight (w/o Straight Cord)

Code No.	Description	Package
64902	Abrasive Belt Width 4 mm #120	2 pcs. each
64904	Abrasive Belt Width 4 mm #240	
64906	Abrasive Belt Width 4 mm #400	
64912	Abrasive Belt Width 6 mm #120	
64914	Abrasive Belt Width 6 mm #240	
64916	Abrasive Belt Width 6 mm #400	
64922	Abrasive Belt Width 8 mm #120	
64924	Abrasive Belt Width 8 mm #240	
64926	Abrasive Belt Width 8 mm #400	

Spare Parts

Product	Description	Code No.	Model
	Tension Pulley	1103	TP-12A
	Tension Pulley Assembly	1104	TPA-12A

LUSTER ◀◀

PISTOL-TYPE RECIPROCATING POLISHING FINISHER

LUSTER Emax EVolution

With Motor ON / OFF Switch Reciprocating Motion Exclusive Tools p.5-13~ 18

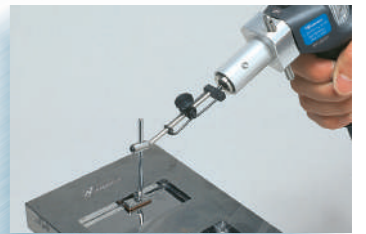

- Powerful reciprocating stroke polisher equipped with 1/4 Speed Reducer to multiply the torque by 4 times.
- Reciprocating speed and stroke can be easily and continuously controlled.
- LUSTER NLS has a built-in motor. Insert the cord plug into the controller.

LUSTER Emax EVolution

Reciprocating Stroke
 0~6,300 times/min

Code No. **1483**

Model **NLS-110**



Stroke Range : 0~6 mm adjustable by allen wrench.

The grinding surface can be set at any angle between 0 and 360° enabling grinding of bottom, right, left and top surfaces without moving the machine itself.
 Mountable tool : Screw clamp type. Max. Tool Shank ø6.4 mm

Designed with comfortable rubber-grip. Well balanced, rubber-grip absorbs vibration from reciprocating strokes reducing fatigue and allowing long, continuous operation.

With Motor ON / OFF Switch

25,000 min⁻¹ Max.

Specifications
 Stroke Range : 0~6 mm (variable)
 Reciprocating Stroke : 0~6,300 times/min (variable)
 Max. Torque : 17.2 cN·m
 Weight : 800 g (w/o cord)
 With Straight Cord : 1.5 m

Standard Accessories
 • Allen Wrench (2 mm), (3 mm) : 1 pc. each
 • Lubricating Oil
 • Lubrication Nozzle for LUSTER
 • Standard Accessories : 1 set

Exclusive Tools p.5-13~ 18



Emax EVolution Controller (p.1-7)
 <Code No. : 8224 (120V) · Model : NE249 120>
 <Code No. : 8227 (230V) · Model : NE249 230>

⚠ Never connect to E-max Series Controller.



Code No.	Outside Diameter	Weight	Max. Torque	Reciprocating Stroke	Max. Tool Shank
1483	Refer to the dimensions	800 g (※)	17.2 cN·m	0~6,300 times/min	ø6.4 mm (screw clamp type)

※ Weight (w/o Straight Cord)

Code No.	Description	Package
62502	Stone Holder	1 pc./pack
62505	Stone Holder	
62751	Spring Holder	
62525	Rectangular Pad	
62526	Rod for Rectangular Pad	

Code No.	Description	Package
62527	Angle Rod	1 pc./pack
62552	Sand Paper Tip #120	10 pcs./pack
62555	Sand Paper Tip #320	
62557	Sand Paper Tip #600	
62559	Sand Paper Tip #1000	

• Exclusive tools for LUSTER p.5-13~ 18

Lever Type Attachment

Code No. **1005** Model **IH-300**



40,000 min⁻¹ Max.

- High precision and high reliability is realized by micron grade precision.
- Slim, lightweight design allows fine finishing of delicate parts.
- Lever Type one touch bur release.



◆ Weight : 62 g
 Standard Size Collet
ø3.0 mm (CHH-3.0) ø2.35 mm (CHH-2.35)
 Optional Collets : CHH Group are shown in page (p.4-3)
 Standard Accessories
 • Wrench (7 x 5.1) : 1 pc. • Pin Wrench (K-233) : 1 pc.
 • L Shaped Wrench (9) : 1 pc.

6 mm Torque Type Attachment

Code No. **1016** Model **HG-200**

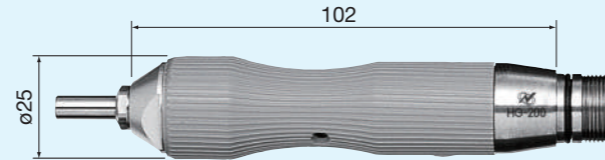

Use ENK-250T to connect HG-200.

30,000 min⁻¹ Max.

- ø6.0 mm shank burs ready.
- The resistance produced by cutting and grinding is absorbed by a special rubber grip to eliminate slipping.
- Collet is tightened by a wrench.



◆ Weight : 210 g
 Standard Size Collet
ø6.0 mm (CHG-6.0)
 Optional Collets : CHG Group are shown in page (p.4-3)
 Standard Accessories
 • Wrench (10 x 10) : 1 pc. • Bar Wrench (K-212) : 1 pc.
 • Pin Wrench (K-233) : 1 pc.

1/4 Speed Reducer

Code No. **1009** Model **RG-01**

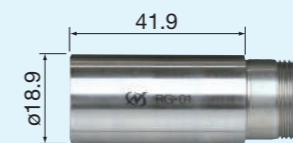

30,000 min⁻¹ Max.

- Mounted between an attachment and a motor.
- The speed is reduced to 1/4 while the torque is multiplied by 4 times.
- Suitable for high torque grinding process or drilling.

◆ Weight : 68 g

Standard Accessories
 • Pin Wrench (K-233) : 1 pc.

Extension Joint

Code No. **1015** Model **CN-01**

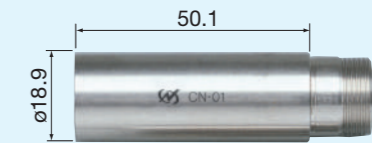

35,000 min⁻¹ Max.

- Speed Ratio 1 : 1
- This is a joint to be connected between a motor and an attachment to extend the total length of the attachment.

◆ Weight : 83 g

Standard Accessories
 • Pin Wrench (K-233) : 1 pc.

LUSTER Attachment (Pistol-Type Polisher)

Code No. **1302** Model **LS-100**

Reciprocating motion

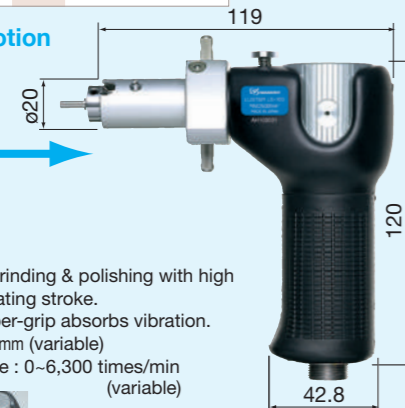

25,000 min⁻¹ Max.

- High performance grinding & polishing with high power and reciprocating stroke.
- Well-balanced, rubber-grip absorbs vibration.
- Stroke Range : 0-6 mm (variable)
- Reciprocating Stroke : 0-6,300 times/min (variable)



◆ Weight : 680 g
 ◆ Max. tool shank diameter ø6.4 mm, Screw clamp type
 Standard Accessories
 • Allen Wrench (2 mm), (3 mm) : 1 pc. each
 • Lubricating Oil • Lubrication Nozzle for LUSTER
 • Standard Accessories : 1 set

Exclusive Tools p.5-13-18

Code No.	Description	Package
62502	Stone Holder	1 pc./pack
62505	Stone Holder	
62751	Spring Holder	
62525	Rectangular Pad	
62526	Rod for Rectangular Pad	10 pcs./pack
62527	Angle Rod	
62552	Sand Paper Tip #120	
62555	Sand Paper Tip #320	
62557	Sand Paper Tip #600	
62559	Sand Paper Tip #1000	

Hammer Attachment

Code No. **8060** Model **HA-500**

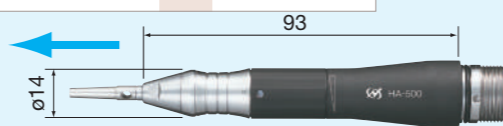

16,000 min⁻¹ Max.

- A wide variety of patterns can be produced by adjusting the spring pressure and hammer speed.
- Lightweight, pencil type grip makes the handpiece very comfortable to hold and easy to use.
- Adjustable spring pressure. ◆ Weight : 95 g
- Self lubricating hammer mechanism ensure excellent durability.
- Stroke Range : 0.4 mm ◆ Stroke Times : 25-4,000 times/min
- ◆ Stroke Spring Pressure : 4.4-7.1 N (Ring Adjustment Type)

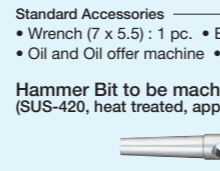

Standard Accessories
 • Wrench (7 x 5.5) : 1 pc. • Bar Wrench (K-212) : 1 pc.
 • Oil and Oil offer machine • Hammer Bit (For replacement) : 2 pcs.

Hammer Bit to be machined to required shapes (SUS-420, heat treated, approx, HRC50)

Code No.	Package
65301	3 pcs./pack

1/15 Speed Reducer

Code No. **1010** Model **RG-02**



30,000 min⁻¹ Max.

- Mounted between an attachment and a motor.
- The speed is reduced to 1/15 while the torque is multiplied by 15 times.
- Suitable for high torque grinding process or drilling.

◆ Weight : 93 g

Standard Accessories
 • Pin Wrench (K-233) : 1 pc.

Foot Controller

Code No. **8106** Model **FC-64**

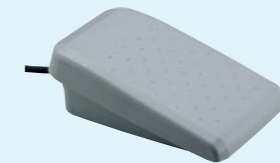

- Variable speed control.
- For Emax EVolution (NE249)

Emax EVolution Torque Set

1,000~25,000 min⁻¹

For heavy duty and larger tools, the Torque type promises to expand the range of operation.

Ring Type IR-310 is the standard attachment for Emax EVolution torque set EV250-120, EV250-230.



Code No. **8234** (120V) Model **EV250-120**

Code No. **8226** (230V) Model **EV250-230**

※ Please check the power source plug type (p.4-6).

- Standard Equipment
- Micro Grinder (IR-310+ENK-250T) : 1 pc.
 - Collet ø3.0 mm (CHH-3.0), ø2.35 mm (CHH-2.35) : 1 pc. each
 - Controller (NE249) : 1 pc.
 - Accessories : Handpiece Holder : 1 pc., Handpiece Stand : 1 pc.
 Power Supply Cord : 1 pc., Wrench (7 x 5.1) : 1 pc.
 Pin Wrench (K-233) : 1 pc., L Shaped Wrench (9) : 1 pc.

HIGH TORQUE BRUSHLESS MICRO-GRINDER

Espert 500 Series

ESPERT 500 SERIES ◀◀



Espert 500 Standard Set

Code No.	9881 (120V)	Model	ES50C-HR
	9882 (230V)		

The Ultimate in Everything

- Speed : 1,000~50,000 min⁻¹
- NAKANISHI Smart Switch
- Max. Output : 200W



Low Noise, Low Vibration

The brushless motor and incorporated cooling fan have reduced the vibration and noise levels dramatically compared with conventional models, resulting in a quieter, more comfortable work environment.

Wide Range of Collets Available

Collet sizes range from a tiny 0.3 mm up, with a wide variety of sizes available. (p.4-3~4)
Tools can be changed without the use of any wrenches.



Espert 500 Compact Motor Handpiece

Code No.	9091	Model	ENK50C-HR
----------	-------------	-------	------------------

Standard Size Collet : ø3.0 mm (CHH-3.0), ø2.35 mm (CHH-2.35)

Features of Motor Handpiece

Speed : 1,000~50,000 min⁻¹

Speed is steplessly variable from 1,000~50,000 min⁻¹. Smooth and powerful torque is delivered at both high and low speeds. The maximum speed of 50,000 min⁻¹ allows high precision micro-processing.

2 Types of Motors

Very high torque from compact motors.

		NAKANISHI Smart Switch Color
• Compact Type	(ENK-500C) 140W	Blue
• Torque Type	(ENK-500T) 200W	Gray

NAKANISHI Smart Switch

The switch has a moderate clicking sensation, and the controller emits a beeping sound in response to operation. The switch color indicates the motor type.



Excellent Durability

High performance brushless motor eliminates the need to change carbon brushes. NAKANISHI's internal load test has demonstrated continuous use for more than 5,000 hours.

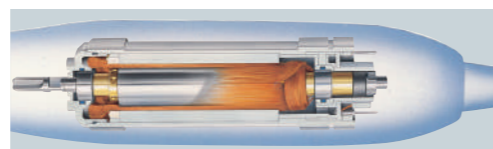

High Precision

NAKANISHI's ultra-precision technology ensures a center runout below 0.02 mm, which allows for very high precision finishing.

Simple Screw on Attachments



Special Dust-Proof Mechanism

This handpiece has a patented built-in-dust protection system to prevent the infiltration of dust and debris into the front bearings. This NAKANISHI patented design assures long-term durability.

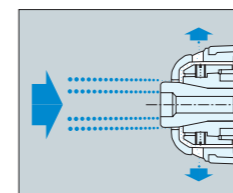

Micro Grinder & Handpiece Stand

This specially designed micromotor stand allows easy pick-up and set-down of the micro-grinder. Strong, but soft to the touch, the micro-grinder stand contains convenient, integrated storage compartments for adjustment wrenches and a spare collet.



9 Types of Attachments Available

9 different types of attachments making an almost infinite number of applications possible.



CAUTION

Electric System

Air System

Ultrasonic

General Parts

Exclusive Tools

CAUTION

Electric System

Air System

Ultrasonic

General Parts

Exclusive Tools

ADVANCED HIGH PERFORMANCE CONTROLLER

Espert 500 Series

ESPERT 500 SERIES ◀◀



Espert 500 Torque Set

Code No.	9883 (120V)	Model	ES50T-HR
	9884 (230V)		

The Ultimate in Everything



Portable Controller with Carrying Handle

Very convenient to be carried.



Features of Controller

Optimal Control via Microcomputer

The operation of all Espert 500 functions is controlled by a high performance microcomputer (CPU) that is programmed with NAKANISHI's proprietary technology. NAKANISHI's CPU has direct control of the brushless micro-grinder allowing smooth and highly precise cutting and polishing of a wide variety of materials. Bur "chatter" has been eliminated. The system automatically senses which micromotor is attached (ENK-500C or ENK-500T) and self adjusts to provide optimum micro-grinder performance.

Auto Cruise Function

The controller is equipped with an auto cruise function that operates the micro-grinder at a preset speed without the need to use the foot pedal. This function eliminates foot fatigue during prolonged operation.

Simplified Hand and Foot Pedal Control

You no longer need to push a switch on the controller to switch between hand and foot pedal control. If you want to operate the motor handpiece by hand simply push the NAKANISHI Smart Switch, if you want to use foot pedal control simply depress the foot pedal.

Memory Speed Function FiXpeed®

An exclusive new feature of the Espert 500 system, the FiXpeed® system allows the user to independently preset the speed of motor A and motor B. For example motor A can be set to maintain the speed set by the FiXpeed® system while motor B has variable control using a foot pedal. This function allows for unprecedented flexibility.

Eco-Friendly Design

The electronic circuits are designed using NAKANISHI's proprietary technology to meet eco-friendly expectations by minimizing power consumption. Since power demands are minimal, no significant heat is generated and no cooling fan is required.

Error Code Display Function

Detects trouble and failures occurring within the motor or unit and displays them as one of seven types of error codes (E0-E6). This reassuring function permits the user to correct the problem. Possible errors are overload, open circuit, motor lock, controller overheat, etc.



Other Features

- Self Check Function (Maintenance Mode)
- Smooth Operation • Operation Check Sound
- Highly Visible and easy to operate front panel
- 2-Digit Digital Display
- A / B 2 Motors Can Be Connected (Simultaneous motor operation is not allowable)

Code No.	9793 (120V)
	9794 (230V)
Model	NE96

* Please check the power source plug type (p.4-6).

Specifications

Description	Espert 500 Controller
Power Source	AC 120/230V, 50-60 Hz
Dimensions	W172 x D230 x H94 mm
Weight	2.6 kg

Accessories : Handpiece Holder : 1 pc.
Handpiece Stand : 1 pc.

CAUTION

Electric System

Air System

Ultrasonic

General Parts

Exclusive Tools

CAUTION

Electric System

Air System

Ultrasonic

General Parts

Exclusive Tools

PRECISION BRUSHLESS MICRO-GRINDER

Esperit 500 Sets

With Motor ON/OFF Switch

- Speed Range : 1,000~50,000 min⁻¹
- Microprocessor controlled for optimal motor control
- Hand Switch [NAKANISHI Smart Switch]
- Memory Speed Function [Fixspeed®]

**High Power &
High Torque !!**



Esperit 500 Standard Set



1,000~50,000 min⁻¹ **140w**

- High Power System.
<Max. Output 140W>

Code No.	9881 (120V)
	9882 (230V)
Model	ES50C-HR

※Please check the power source plug type (p.4-6).

- Standard Equipment
- Controller (NE96) : 1 pc.
 - Compact Motor Handpiece (ENK50C-HR) : 1 pc.

- Standard Accessories
- Collet ø3.0 mm (CHH-3.0), ø2.35 mm (CHH-2.35)
 - Handpiece Holder : 1 pc. • Handpiece Stand : 1 pc.
 - Wrench (7 x 5.1) : 1 pc. • Pin Wrench (K-233) : 1 pc.
 - L Shaped Wrench (9) : 1 pc.

Esperit 500 Torque Set



1,000~50,000 min⁻¹ **200w**

- Highest Power in its Class.
<Max. Output 200W>

Code No.	9883 (120V)
	9884 (230V)
Model	ES50T-HR

※Please check the power source plug type (p.4-6).

- Standard Equipment
- Controller (NE96) : 1 pc.
 - Torque Motor Handpiece (ENK50T-HR) : 1 pc.

- Standard Accessories
- Collet ø3.0 mm (CHH-3.0), ø2.35 mm (CHH-2.35)
 - Handpiece Holder : 1 pc. • Handpiece Stand : 1 pc.
 - Wrench (7 x 5.1) : 1 pc. • Pin Wrench (K-233) : 1 pc.
 - L Shaped Wrench (9) : 1 pc.

PRECISION BRUSHLESS MICRO-GRINDER

Esperit 500 Motor Handpiece

With Motor ON/OFF Switch

1,000~50,000 min⁻¹

- Speed Range : 1,000~50,000 min⁻¹
- Microprocessor controlled for optimal motor control
- Hand Switch [NAKANISHI Smart Switch]
- Memory Speed Function [Fixspeed®]

MOTOR-HANDPIECE



Esperit 500 Compact Motor Handpiece

1,000~50,000 min⁻¹ **140w**

Code No.	9091
Model	ENK50C-HR

Standard Size Collet

ø3.0 mm (CHH-3.0) ø2.35 mm (CHH-2.35)
Optional Collets : CHH Group are shown in page (p.4-3)

- Standard Accessories
- Wrench (7 x 5.1) : 1 pc.
 - Pin Wrench (K-233) : 1 pc.
 - L Shaped Wrench (9) : 1 pc.



Esperit 500 Torque Motor Handpiece

1,000~50,000 min⁻¹ **200w**

Code No.	9092
Model	ENK50T-HR

Standard Size Collet

ø3.0 mm (CHH-3.0) ø2.35 mm (CHH-2.35)
Optional Collets : CHH Group are shown in page (p.4-3)

- Standard Accessories
- Wrench (7 x 5.1) : 1 pc.
 - Pin Wrench (K-233) : 1 pc.
 - L Shaped Wrench (9) : 1 pc.

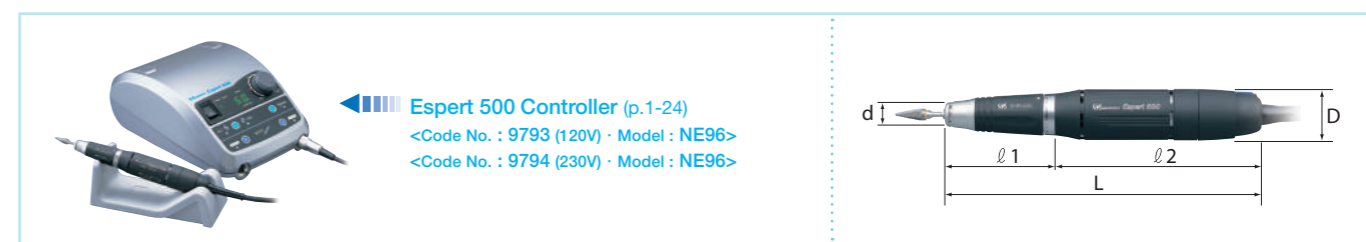

Code No.	d	D	l1	l2	L	Weight	Max. Output	Speed Range	Collet
9091	ø13.3	ø26.8	59.4	107.8	167.2	210 g(*)	140W	1,000~50,000 min ⁻¹	ø0.3~ø3.175 mm
9092	ø13.3	ø28.3	59.4	121.4	180.8	250 g(*)	200W	1,000~50,000 min ⁻¹	CHH Group (p.4-3)

※ Weight (w/o Coiled Cord)

CAUTION
Electric System
Air System
Ultrasonic
General Parts
Exclusive Tools

CAUTION
Electric System
Air System
Ultrasonic
General Parts
Exclusive Tools

Espert 500 Series System Chart

Code No.	Model
Attachment	
Ring Type	
9090	EHR-500
Lever Type	
1515	EHL-401
6 mm Torque Type	
1552	EHG-400
90° Angle Type	
1525	EIC-300
50° Angle Type	
1526	EKC-300
90° Angle Torque Type	
1551	ERA-270
LUSTER (Reciprocating motion)	
1516	ELS-100
MINI-LUSTER (Reciprocating motion)	
1554	EML-8
FINE BELT SANDER	
1145	EBS-101
Speed Reducer	
1/4 Speed Reducer	
1553	ERG-01B
• May be connected between the motor and the attachment when required increased torque.	
Motor	
Compact Motor with Cord	
9088	ENK-500C
1,000~50,000 min ⁻¹	
Torque Motor with Cord	
9089	ENK-500T
1,000~50,000 min ⁻¹	
Controller	
Espert 500 Controller	
9793 (120V)	NE96
9794 (230V)	
Sets	
Espert 500 Standard Set	
Code No.	Model
9881 (120V)	ES50C-HR
9882 (230V)	
Standard Equipment	
• Compact Motor Handpiece (ENK50C-HR) : 1 pc.	
• Collet ø3.0 mm (CHH-3.0), ø2.35 mm (CHH-2.35)	
• Controller (NE96) : 1 pc.	
Standard Accessories	
• Handpiece Holder : 1 pc. • Handpiece Stand : 1 pc.	
• Wrench (7 x 5.1) : 1 pc. • Pin Wrench (K-233) : 1 pc.	
• L Shaped Wrench (9) : 1 pc.	
Emax EVOLUTION, ELECTER E-max and ROTUS attachments can be connected using these adaptors.	
Extension Adaptor	
1518	ECN-011
1/4 Speed Reducer	
1517	ERG-01

⚠ Details of Maximum Allowable speed on intermittent use or continuous use p.1-29-31

Espert 500 Series

Espert 500 Controller

Code No.	9793 (120V)
	9794 (230V)
Model	NE96

- Microprocessor controlled for optimal motor control.
- Memory Speed Function FiXspeed®.
- ◆ Power Source : AC120/230V, 50-60 Hz
- ◆ Dimensions : W172 x D230 x H94 mm
- ◆ Weight : 2.6 kg

Standard Accessories
 • Handpiece Holder : 1 pc. • Handpiece Stand : 1 pc.

※ Please check the power supply cord plug type (p.4-6).



Espert 500 Compact Type Motor

Code No.	9088
Model	ENK-500C

1,000~50,000 min⁻¹

- Incorporates the NAKANISHI Smart Switch for easy ON / OFF operation.
- Small, lightweight, high-speed brushless DC motor.

- ◆ Output Power : 140 W
- ◆ Max. Torque : 6.0 cN·m
- ◆ Cord Length : 1.5 m
- ◆ Weight : 115 g (w/o cord)



Espert 500 Torque Type Motor

Code No.	9089
Model	ENK-500T

1,000~50,000 min⁻¹

- Incorporates the NAKANISHI Smart Switch for easy ON / OFF operation.
- High-power, high-torque, high-speed brushless DC motor.

- ◆ Output Power : 200 W
- ◆ Max. Torque : 8.7 cN·m
- ◆ Cord Length : 1.5 m
- ◆ Weight : 160 g (w/o cord)



Ring Type Attachment

Code No. **9090** Model **EHR-500**



- 50,000 min⁻¹ Max.**
- High precision and high reliability is realized by micron grade precision.
 - Slim, lightweight design allows for fine finishing of delicate parts.
 - One-touch ring type bur replacement.



◆ Weight : 94 g
 Standard Size Collet
ø3.0 mm (CHH-3.0) ø2.35 mm (CHH-2.35)
 Optional Collets : CHH Group are shown in page (p.4-3)
 Standard Accessories
 • Wrench (7 x 5.1) : 1 pc. • Pin Wrench (K-233) : 1 pc.
 • L Shaped Wrench (9) : 1 pc.

Lever Type Attachment

Code No. **1515** Model **EHL-401**



- 50,000 min⁻¹ Max.**
- High precision and high reliability is realized by micron grade precision.
 - Slim, lightweight design allows for fine finishing of delicate parts.
 - Lever Type one touch bur release.



◆ Weight : 70 g
 Standard Size Collet
ø3.0 mm (CHH-3.0) ø2.35 mm (CHH-2.35)
 Optional Collets : CHH Group are shown in page (p.4-3)
 Standard Accessories
 • Wrench (7 x 5.1) : 1 pc. • Pin Wrench (K-233) : 1 pc.

6 mm Torque Type Attachment

Code No. **1552** Model **EHG-400**



- 40,000 min⁻¹ Max.**
- ø6.0 mm shank burs ready.
 - Collet is tightened by a wrench.



◆ Weight : 110 g
 Standard Size Collet
ø6.0 mm (CHG-6.0)
 Optional Collets : CHG Group are shown in page (p.4-3)
 Standard Accessories
 • Wrench (10 x 10) : 1 pc.
 • Bar Wrench (K-212) : 1 pc.

90° Angle Torque Attachment

Code No. **1551** Model **ERA-270**



- 27,000 min⁻¹ Max.**
- Large gear for better durability and high load capacity.
 - Perfect for finishing bottom surfaces and other tight, hard to reach areas.
 - Suitable for polishing a flat surface at speed with a grinding disk pad.



◆ Speed Reduction Ratio : 1/1.5
 ◆ Weight : 107 g
 Standard Size Collet **ø3.0 mm (CHS-3.0)**
 Optional Collets : CHS Group are shown in page (p.4-4)
 Standard Accessories
 • Wrench (8 x 5) , (7 x 5.1) , (20 x 24) : 1 pc. each

90° Angle Attachment

Code No. **1525** Model **EIC-300**

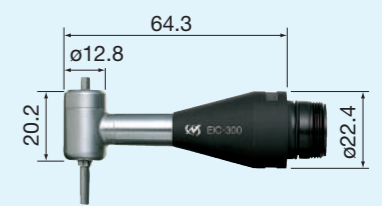

- 30,000 min⁻¹ Max.**
- Suitable for polishing a flat surface at speed with a grinding disk pad.
 - Capable of applications for rough cutting to mirror finishing.
 - Speed Reduction Ratio : 3/4



◆ Weight : 54 g
 Standard Size Collet **ø3.0 mm (CHC-3.0)**
 Optional Collets : CHC Group are shown in page (p.4-3)
 Standard Accessories
 • Wrench (20 x 24) : 1 pc.
 • Collet Wrench (K-231) : 1 pc.
 • Standard Accessories : 1 set

Code No.	Description	Package
64101	Rubber Pad (Small) O.D. ø10 mm	1 pc./pack
64102	Rubber Pad (Med) O.D. ø20 mm	
64103	Rubber Pad (Large) O.D. ø30 mm	
64203	Sand Paper Disk for small pad ø11 #180	5 pcs./pack
64207	Sand Paper Disk for small pad ø11 #600	
64213	Sand Paper Disk for med. pad ø21 #180	
64217	Sand Paper Disk for med. pad ø21 #600	
64223	Sand Paper Disk for large pad ø31 #180	
64227	Sand Paper Disk for large pad ø31 #600	

CAUTION

CAUTION

Electric System

Electric System

Air System

Air System

Ultrasonic

Ultrasonic

General Parts

General Parts

Exclusive Tools

Exclusive Tools

50° Angle Attachment

Code No. **1526** Model **EKC-300**

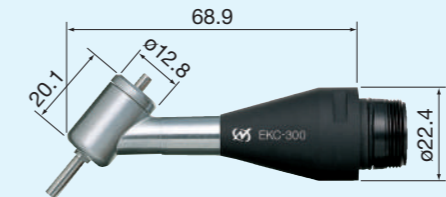

- 30,000 min⁻¹ Max.**
- Perfect for finishing bottom surfaces and other tight, hard to reach areas.
 - Suitable for polishing a flat surface at speed with a grinding disk pad.
 - Speed Reduction Ratio : 3/4. Use the motor in reverse rotation for clockwise rotation.



◆ Weight : 54 g
 Standard Size Collet **ø3.0 mm (CHC-3.0)**
 Optional Collets : CHC Group are shown in page (p.4-3)
 Standard Accessories
 • Wrench (20 x 24) : 1 pc.
 • Collet Wrench (K-231) : 1 pc.
 • Standard Accessories : 1 set

Code No.	Description	Package
64101	Rubber Pad (Small) O.D. ø10 mm	1 pc./pack
64102	Rubber Pad (Med) O.D. ø20 mm	
64103	Rubber Pad (Large) O.D. ø30 mm	
64203	Sand Paper Disk for small pad ø11 #180	5 pcs./pack
64207	Sand Paper Disk for small pad ø11 #600	
64213	Sand Paper Disk for med. pad ø21 #180	
64217	Sand Paper Disk for med. pad ø21 #600	
64223	Sand Paper Disk for large pad ø31 #180	
64227	Sand Paper Disk for large pad ø31 #600	

LUSTER Attachment (Pistol-Type Polisher)

Code No. **1516** Model **ELS-100**

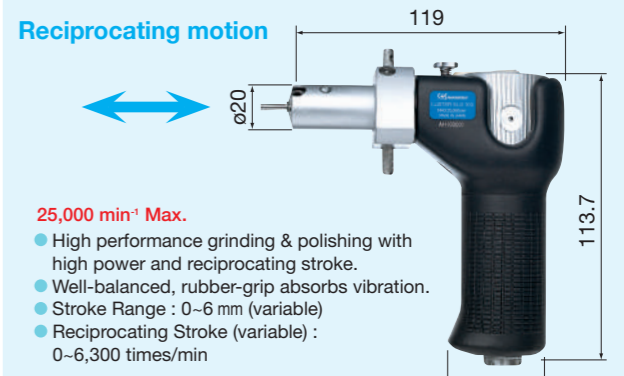

- 25,000 min⁻¹ Max.**
- High performance grinding & polishing with high power and reciprocating stroke.
 - Well-balanced, rubber-grip absorbs vibration.
 - Stroke Range : 0-6 mm (variable)
 - Reciprocating Stroke (variable) : 0-6,300 times/min



◆ Weight : 680 g
 ◆ Max. tool shank diameter ø6.4 mm, Screw clamp type
 Standard Accessories
 • Allen Wrench (2 mm), (3 mm) : 1 pc. each
 • Lubricating Oil • Lubrication Nozzle for LUSTER
 • Standard Accessories : 1 set

Code No.	Description	Package
62502	Stone Holder	1 pc./pack
62505	Stone Holder	
62751	Spring Holder	
62525	Rectangular Pad	10 pcs./pack
62526	Rod for Rectangular Pad	
62527	Angle Rod	
62552	Sand Paper Tip #120	
62555	Sand Paper Tip #320	
62557	Sand Paper Tip #600	
62559	Sand Paper Tip #1000	

MINI-LUSTER Attachment (Pencil-Type Reciprocating Polishing Finisher)

Code No. **1554** Model **EML-8** Stroke (0.8 mm)

Reciprocating motion

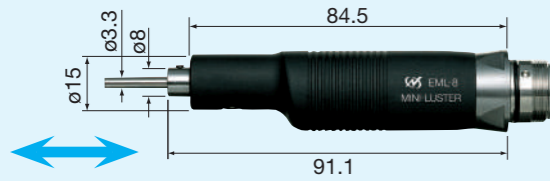

- 25,000 min⁻¹ Max.**
- High Speed reciprocating polisher for rapid finishing of small surfaces.
 - The lightweight pencil type design makes it very controllable.
 - Ideal for small, tight areas such as tight corners, ribs, etc.
 - Reciprocating Speed (variable) : 0~10,000 strokes/min
 - Weight : 130 g
 - Max. tool shank diameter $\phi 3.5$ mm, Screw clamp type

Exclusive Tools p.5-19~22

Standard Accessories
• Allen Wrench (1.5mm) : 1 pc. • Standard Accessories : 1 set

Code No.	Description	Package
62751	Spring Holder	1 pc./pack
62510	Ceramic Fiber Grindstone Holder	
62814	Electroplated Diamond File 1.25 x 4 x 50 #100	
60520	Ceramic Fiber Grindstone 1 x 6 x 50 #1200	

FINE BELT SANDER Attachment

Code No. **1145** Model **EBS-101**

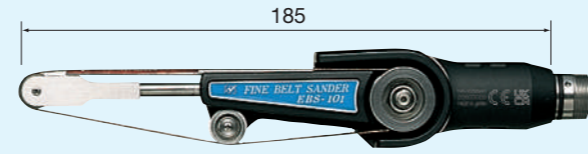

30,000 min⁻¹ Max.

- Very high belt speed, ideal for applications from deburring to radius finishing.
- Belt Speed : 0~705 m/min
- Weight : 355 g
- Belt Sizes : 4, 6, 8 mm wide x 300 mm long

Standard Accessories
• Allen Wrench (3 mm) : 1 pc.
• Standard Accessories : 1 set

Code No.	Description	Package
64902	Abrasive Belt Width 4 mm #120	2 pcs. each
64904	Abrasive Belt Width 4 mm #240	
64906	Abrasive Belt Width 4 mm #400	
64912	Abrasive Belt Width 6 mm #120	
64914	Abrasive Belt Width 6 mm #240	
64916	Abrasive Belt Width 6 mm #400	
64922	Abrasive Belt Width 8 mm #120	
64924	Abrasive Belt Width 8 mm #240	
64926	Abrasive Belt Width 8 mm #400	

Exclusive Tools p.5-32

1/4 Speed Reducer

Code No. **1553** Model **ERG-01B**

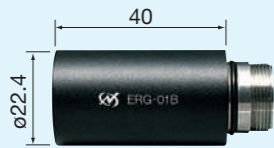

- 30,000 min⁻¹ Max.**
- Mounted between an attachment and a motor.
 - The speed is reduced to 1/4 while the torque is multiplied by 4 times.
 - Suitable for high torque grinding process or drilling.
 - Weight : 65 g

Standard Accessories
• Pin Wrench (K-233) : 1 pc.

Extension Adaptor

Code No. **1518** Model **ECN-011**



- 40,000 min⁻¹ Max.**
- The Adaptor can be used with the attachments for Emax EVOLUTION, E-max and ROTUS you already have.
 - Weight : 31 g

Standard Accessories
• Wrench (20 x 24) : 1 pc.

1/4 Speed Reducer

Code No. **1517** Model **ERG-01**



- 30,000 min⁻¹ Max.**
- The Speed Reducer can be used with the attachments for Emax EVOLUTION, E-max and ROTUS you already have.
 - The speed is reduced to 1/4 while the torque is multiplied by 4 times.
 - Suitable for high torque grinding process or drilling.
 - Weight : 62 g

Standard Accessories
• Pin Wrench (K-233) : 1 pc.

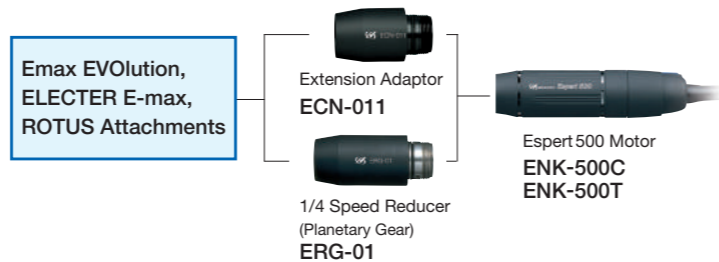

Esper 500 Series Spare Parts

Product	Description	Code No.	Model	Specifications
	Foot Pedal	1440	FC-40	• Variable Speed Control
	Esper 500 Handpiece Stand	8104	K-274	—
	Esper 500 Compact Motor Cord	9093	ENKCD-50C	• Compact Motor Cord • 1.5 m Long
	Esper 500 Torque Motor Cord	9094	ENKCD-50T	• Torque Motor Cord • 1.5 m Long

CAUTION

Electric System

Air System

Ultrasonic

General Parts

Exclusive Tools

CAUTION

Electric System

Air System

Ultrasonic

General Parts

Exclusive Tools

Air System Products

INDEX

▶▶▶ ROTUS Series

Features	p.2-3~4
System Chart	p.2-5
Air Motor	p.2-6
Set Product	p.2-6
Attachment / Air Motor / Parts	p.2-7~10



Attachment Type
Micro Air Grinder
30,000 min⁻¹

▶▶▶ IMPULSE Series

Features	p.2-11~12
Air Grinders	p.2-13~14
Parts / Tools	p.2-15~17



Pencil Type Air Grinder
60,000 min⁻¹

▶▶▶ PRESTO II

Set Product / Handpiece / Parts	p.2-18
---------------------------------------	--------



Ultra-High Speed Air Turbine Grinder
320,000 min⁻¹

CAUTION
Electric System
Air System
Ultrasonic
General Parts
Exclusive Tools

CAUTION
Electric System
Air System
Ultrasonic
General Parts
Exclusive Tools

ATTACHMENT TYPE MICRO AIR GRINDER

ROTUS Series

ROTUS SERIES ◀◀



ROTUS Standard Set
Code No. **1163** Model **ROTUS-IR**



- **Compatibility**
Compatible with a variety of attachments ideal for any application.
- **High-power and High-torque**
Equipped with an ultra-precision NAKANISHI special vane motor, this machine maintains a stable grinding process by maintaining the rotational speed even under fluctuating grinding loads.
- **Light-Weighted, Compact body**
NAKANISHI products are focused on high precision and high quality, pursuing ideal ease of use, lightweight and a compact size, as well as exquisite balance and good handling.
- **A wide variety of tools**
A wide variety of NAKANISHI original tools are available to support processing along with products.

A Special Rotary Vane Air Motor is Incorporated

The air motor utilizes a special vane design which keeps constant speed even under load, to provide stable grinding and polishing operation.

Excellent quietness with Silencer

By attaching the silencer to the end of the exhaust air tubing, the motor operates extremely quietly.

Twist Free Hose

The grinder and dual hoses (air supply and exhaust) are not fixed, and the hoses swivel freely 360° without twisting. (IM-301)



13 Types of Attachments Available

13 different types of attachments making an almost infinite number of applications possible.



※ ROTUS Attachment is compatible with Emax EVolution. System Chart Emax EVolution Series / ROTUS Series (p.1-9~10)

Ring Type Attachment

Code No.	1147	Model	IR-310
----------	-------------	-------	---------------

ROTUS Air Motor

Code No.	1004	Model	IM-301
----------	-------------	-------	---------------

Set-Up Drawing



■ Use Air Line Kit AL-H1207F or air supply 3 pieces set. (Air Filter, Air Regulator, Lubricator)

CAUTION
Electric System
Air System
Ultrasonic
General Parts
Exclusive Tools

CAUTION
Electric System
Air System
Ultrasonic
General Parts
Exclusive Tools

ROTUS Series System Chart

Code No. Model

1147 IR-310



Attachment

Ring Type

1005 IH-300



Lever Type

1016 HG-200



6 mm Torque Type

1017 BMH-300



Long Type

1012 MFC-300S



90° Mini Angle Type

1013 MFC-300M



90° Mini Angle Type (Very Small Head)

1006 IC-300



90° Angle Type

1014 KC-300



50° Angle Type

LUSTER

1302 LS-100



Pistol-Type Polisher (Reciprocating motion)

MINI-LUSTER

1307 ML-8



Pencil-Type Reciprocating Polishing Finisher (Reciprocating motion)

SWING-LUSTER

1380 SLS-16



Pencil-Type Reciprocating Polishing Finisher (Right to left motion)

Hammer Action Type

8060 HA-500



Engraving and Ornament Processing Work Hammer

FINE BELT SANDER

1146 KBS-101



Small-sized Handy Belt Sander

Speed Reducer-Extension Joint



Extension Joint
1015 CN-01



1/4 Speed Reducer
1009 RG-01



1/15 Speed Reducer
1010 RG-02

※ Can be connected between the motor and the attachment when a higher level of torque is required.

Motor



• Air Motor with Hose 360° Twist-Free Joint Mechanism
1004 IM-301 3,000~30,000 min⁻¹

Air Driven

• Air Line Kit



4507 AL-H1207F

• Foot Controller



1064 AFC-45

※ This air line kit is designed for use with the AFC-45 Foot Controller, Code No.1064.

⚠ Details of Maximum Allowable speed on intermittent use or continuous use p.2-7~10

ROTUS SERIES

PRECISION HIGH TORQUE AIR MOTOR • STANDARD SET

ROTUS Air Motor • Standard Set

3,000~30,000 min⁻¹

- High performance air motor with high torque. The vane and cylinder, which are the result of NAKANISHI's ultra-precision machining expertise, minimize the decrease in rotational speed due to cutting load.
- This high performance air motor with minimal power loss from load fluctuation has excellent performance in its grinding stability. Moreover, the motor with minimal air consumption runs quietly and the energy-saving mechanism makes it possible to operate with a 0.75KW (1hp) air compressor.
- Lightweight and compact design. 130 g (w/o hose)
- 13 types of attachments for all types of applications.
- ON / OFF, FWD. / REV. Rotation Direction and Motor Speed can be controlled only by the Ring Switch.
 - ◆ Foot controller is available (p. 2-10) : variable speed control.
- Cooling system suppresses heat for continuous operation.
- By attaching the silencer to the end of the exhaust air tubing, the noise level can be reduced to an outstanding level.
- Twist-Free Joint mechanism is installed in the IM-301 to solve the problem of hose twisting.

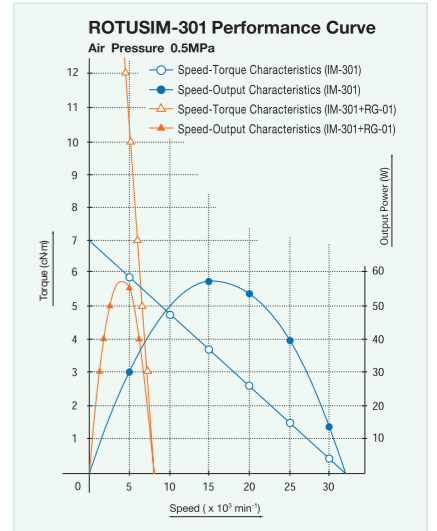

ROTUS Air Motor (with Twist-Free Joint Mechanism)

2,000~30,000 min⁻¹

Code No. 1004 Model IM-301

- ◆ Speed : Max. 30,000 min⁻¹ (0.4 MPa)
- ◆ Proper Air Pressure : 0.3~0.45 MPa
- ◆ Air Consumption : 75 Nℓ / min ◆ Output Power : 46 W
- ◆ Max. Torque : 6.6 cN·m (0.4 MPa) ◆ Weight : 130 g (w/o hose)

Standard Accessories
• Hose (K-206) : 2 m • Silencer (K-209) • Pin Wrench (K-233) : 1 pc.



<Air Motor with 360° Twist-Free Joint Mechanism>

- The Twist-Free Joint mechanism will avoid hose twisting.



ROTUS Standard Set



30,000 min⁻¹ (Speed)

The ROTUS System is a hand-held grinder with an energy saving air motor. Since it is an air driven system, there is virtually no heat generated to result in excellent durability. Select from a variety of attachments depending on the application.

The Ring type IR-310 is a standard attachment for the ROTUS standard set ROTUS-IR.

Code No. 1163 Model ROTUS-IR

Standard Equipment

- Air Grinder (IR-310+IM-301) : 1 pc.
- Collet ø3.0mm (CHH-3.0), ø2.35 mm (CHH-2.35) : 1 pc. each
- Air Line Kit (AL-H1207F) : 1 pc. • Foot Controller (AFC-45) : 1 pc.
- Accessories : Piping Hose 2m (K-275) : 1 pc., Lubricating Oil (K-211) : 1 pc. Wrench (7 x 5.1) : 1 pc., Pin Wrench (K-233) : 2 pcs. L Shaped Wrench (9) : 1 pc.

Specifications (IR-310 + IM-301)

Weight	Max. Torque	Speed	Proper Air Pressure	Air Consumption	Output Power	Collet
222g(※)	6.6 cN·m (0.4 MPa)	30,000 min ⁻¹	0.3~0.45 MPa	75 Nℓ /min	46 W (Motor)	ø0.3~ø3.175 mm CHH Group (p.4-3)

※ Weight (w/o Hose)

◆ Order by Code No.

Ring Type Attachment

Code No. **1147** Model **IR-310**

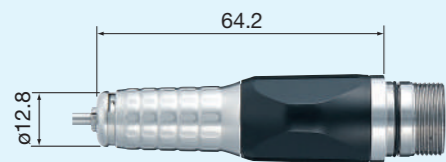

40,000 min⁻¹ Max.

- High precision and high reliability is realized by micron grade precision.
- Slim, lightweight design allows for fine finishing of delicate parts.
- One-touch ring type bur replacement.



◆ Weight : 92 g
 Standard Size Collet
 ø3.0 mm (CHH-3.0) ø2.35 mm (CHH-2.35)
 Optional Collets : CHH Group are shown in page (p.4-3)
 Standard Accessories
 • Wrench (7 x 5.1) : 1 pc. • Pin Wrench (K-233) : 1 pc.
 • L Shaped Wrench (9) : 1 pc.

Lever Type Attachment

Code No. **1005** Model **IH-300**

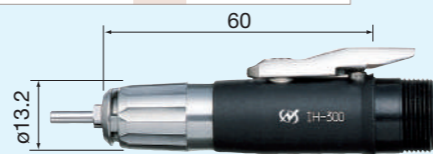

40,000 min⁻¹ Max.

- High precision and high reliability is realized by micron grade precision.
- Slim, lightweight design allows for fine finishing of delicate parts.
- Lever Type one touch bur release.



◆ Weight : 62 g
 Standard Size Collet
 ø3.0 mm (CHH-3.0) ø2.35 mm (CHH-2.35)
 Optional Collets : CHH Group are shown in page (p.4-3)
 Standard Accessories
 • Wrench (7 x 5.1) : 1 pc.
 • Pin Wrench (K-233) : 1 pc.

SWING-LUSTER Attachment

Code No. **1380** Model **SLS-16**



30,000 min⁻¹ Max.

- High speed grinding and polishing operations can be performed while maintaining the fine and delicate feel of hand polishing.
- Lightweight pencil type design makes it easy to work in tight areas.
- Easily adjustable stroke length allows efficient work on minute areas or large sections.
- Weight : 127 g ◆ Stroke Range (variable) : 0~1.6 mm
- ◆ Reciprocating Stroke (variable) : 0~7,650 times/min
- ◆ Max. tool shank diameter ø5.0 mm, Screw clamp type

Standard Accessories
 • Wrench (16 x 18), (20 x 24) : 1 pc. each
 • Allen Wrench (1.5 mm) : 1 pc. • Standard Accessories : 1 set
 Standard Accessories

Code No.	Description	Package
62510	Ceramic Fiber Grindstone Holder	1 pc. each
62814	Electroplated Diamond File 1.25 x 4 x 50 #100	
60520	Ceramic Fiber Grindstone 1 x 6 x 50 #1200	

Hammer Attachment

Code No. **8060** Model **HA-500**

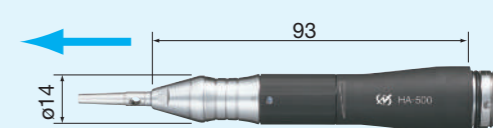

16,000 min⁻¹ Max.

Please use it with Speed Reducer.

- A wide variety of patterns can be produced by adjusting the spring pressure and hammer speed.
- Light weight, pencil type grip makes the handpiece very comfortable to hold and easy to use.
- Adjustable spring pressure. ◆ Weight : 95 g
- Self lubricating hammer mechanism ensure excellent durability.
- ◆ Stroke Range : 0.4 mm ◆ Stroke Times : 25~4,000 times/min
- ◆ Stroke Spring Pressure : 4.4~7.1 N (Ring Adjustment Type)

Standard Accessories
 • Wrench (7 x 5.5) : 1 pc. • Bar Wrench (K-212) : 1 pc.
 • Oil and Oil offer machine • Hammer Bit (For replacement) : 2 pcs.

Hammer Bit to be machined to required shapes (SUS-420, heat treated, approx, HRC50)

Code No.	Package
65301	3 pcs./pack

6 mm Torque Type Attachment

Code No. **1016** Model **HG-200**

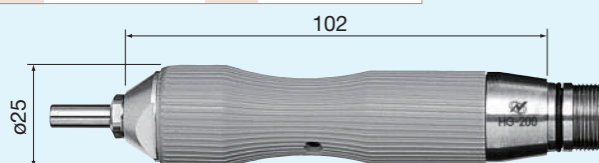

30,000 min⁻¹ Max.

Please use it with Speed Reducer.

- ø6.0 mm shank burs ready.
- The resistance produced by cutting and grinding is absorbed by a special rubber grip to eliminate slipping.
- The bur needs to be secured with a wrench.



◆ Weight : 210 g
 Standard Size Collet
 ø6.0 mm (CHG-6.0)
 Optional Collets : CHG Group are shown in page (p.4-3)
 Standard Accessories
 • Wrench (10 x 10) : 1 pc. • Bar Wrench (K-212) : 1 pc.
 • Pin Wrench (K-233) : 1 pc.

Long Type Attachment

Code No. **1017** Model **BMH-300**



35,000 min⁻¹ Max.

- This unique slim body makes it ideal for cutting and grinding the bottom surface of deep ribs or holes.
- The bur needs to be secured with a wrench.



◆ Weight : 156 g
 Standard Size Collet
 ø3.0 mm (CHM-3.0)
 Optional Collets : CHM Group are shown in page (p.4-4)
 Standard Accessories
 • Wrench (7 x 5.1), (6 x 4.5) : 1 pc. each
 • Pin Wrench (K-233) : 1 pc.

ROTUS Air Motor (with Chip Air Mechanism)

Code No. **1003** Model **IM-300**

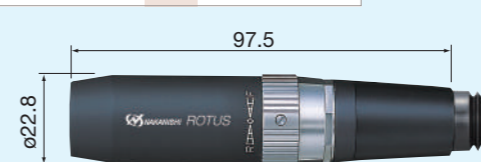

- ◆ Speed : 3,000~30,000 min⁻¹ ◆ Proper Air Pressure : 0.3~0.45 MPa
- ◆ Air Consumption : 75 Nl / min ◆ Output Power : 46 W
- ◆ Max. Torque : 6.6 cN·m (0.4MPa) ◆ Weight : 130 g (w/o hose)

Standard Accessories
 • Hose (K-207) : 2 m • Silencer (K-209) • Pin Wrench (K-233) : 1 pc.

<Air Motor with Chip Air Mechanism>

- Air Motor with Chip Air Mechanism
 Clean air is blown from the tip of the attachment to blow away cutting dust. The cooling effect reduces cutting heat and extends the life of the attachment.



This is only with the attachment IH-300.

90° Mini Angle Type Attachment

Code No. **1013** Model **MFC-300M**

For Chamfering Deep Hole, Bur Only ø1.6 mm

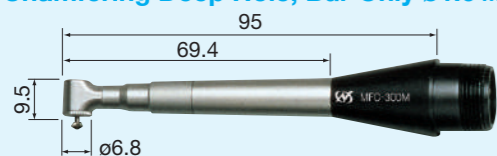

15,000 min⁻¹ Max.

Please use it with Speed Reducer.

- The smallest angle type attachment in NAKANISHI's lineup.
- Suitable for chamfering and deburring the inside of the slit pipe.

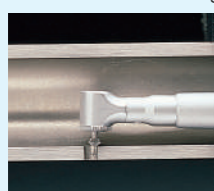

◆ Minimum Inner Diameter : ø13 mm
 ◆ Holding tool width : 7.2 mm ◆ Weight : 47 g
 ◆ Speed Reduction Ratio : 10/11
 Standard Size Collet
 ø1.6 mm (K-253) p.4-4
 Standard Accessories
 • Collet Wrench (K-232) : 1 pc. • Pin Wrench (K-233) : 1 pc.

90° Mini Angle Type Attachment

Code No. **1012** Model **MFC-300S**

For Chamfering Deep Hole, Bur Only ø1.6 mm

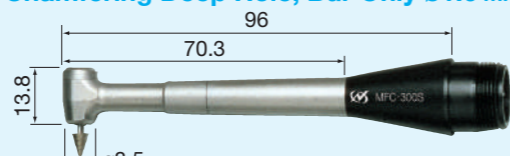

15,000 min⁻¹ Max.

Please use it with Speed Reducer.

- Suitable for chamfering and deburring the inside of the slit pipe.
- ◆ Minimum Inner Diameter : ø20 mm



◆ Holding tool width : 11.9 mm
 ◆ Weight : 50 g
 ◆ Speed Reduction Ratio : 10/11
 Standard Size Collet
 ø1.6 mm (K-252) p.4-4
 Standard Accessories
 • Collet Wrench (K-232) : 1 pc. • Pin Wrench (K-233) : 1 pc.

90° Angle Attachment

Code No. **1006** Model **IC-300**

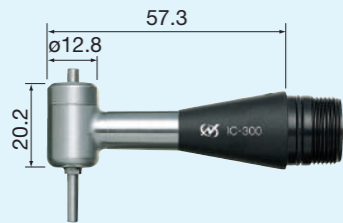

30,000 min⁻¹ Max.
Please use it with Speed Reducer.

- Suitable for polishing a flat surface at speed with a grinding disk pad.
- Capable of applications for rough cutting to mirror finishing.
- Speed Reduction Ratio : 3/4



◆ Weight : 45 g
◆ Standard Size Collet **3.0 mm (CHC-3.0)** **Exclusive Tools** p.5-25~30
Optional Collets : CHC Group are shown in page (p.4-3)
Standard Accessories
• Collet Wrench (K-231) : 1 pc.
• Pin Wrench (K-233) : 1 pc.
• Standard Accessories : 1 set

Code No.	Description	Package
64101	Rubber Pad (Small) O.D. φ10 mm	1 pc./pack
64102	Rubber Pad (Med) O.D. φ20 mm	
64103	Rubber Pad (Large) O.D. φ30 mm	
64203	Sand Paper Disk for small pad φ11 #180	5 pcs./pack
64207	Sand Paper Disk for small pad φ11 #600	
64213	Sand Paper Disk for med. pad φ21 #180	
64217	Sand Paper Disk for med. pad φ21 #600	
64223	Sand Paper Disk for large pad φ31 #180	
64227	Sand Paper Disk for large pad φ31 #600	

50° Angle Attachment

Code No. **1014** Model **KC-300**

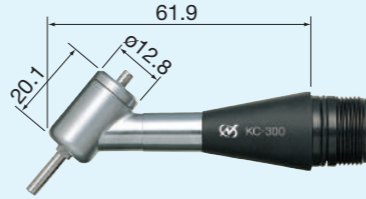

30,000 min⁻¹ Max.
Please use it with Speed Reducer.

- Perfect for finishing bottom surfaces and other tight, hard to reach areas.
- Suitable for polishing a flat surface at speed with a grinding disk pad.
- Speed Reduction Ratio : 3/4

Use the motor in reverse rotation for clockwise rotation.



◆ Weight : 45 g
◆ Standard Size Collet **3.0 mm (CHC-3.0)** **Exclusive Tools** p.5-25~30
Optional Collets : CHC Group are shown in page (p.4-3)
Standard Accessories
• Collet Wrench (K-231) : 1 pc.
• Pin Wrench (K-233) : 1 pc.
• Standard Accessories : 1 set

Code No.	Description	Package
64101	Rubber Pad (Small) O.D. φ10 mm	1 pc./pack
64102	Rubber Pad (Med) O.D. φ20 mm	
64103	Rubber Pad (Large) O.D. φ30 mm	
64203	Sand Paper Disk for small pad φ11 #180	5 pcs./pack
64207	Sand Paper Disk for small pad φ11 #600	
64213	Sand Paper Disk for med. pad φ21 #180	
64217	Sand Paper Disk for med. pad φ21 #600	
64223	Sand Paper Disk for large pad φ31 #180	
64227	Sand Paper Disk for large pad φ31 #600	

FINE BELT SANDER Attachment

Code No. **1146** Model **KBS-101**

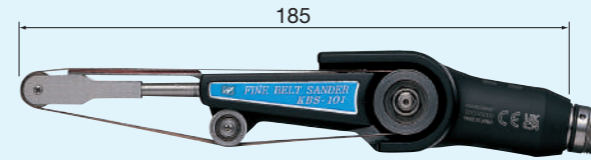

30,000 min⁻¹ Max.

- Very high belt speed, ideal for applications from deburring to finishing.
- The angle of the belt section is fully adjustable.



◆ Belt Speed : 0~705 m/min
◆ Weight : 350 g
◆ Belt Sizes : 4, 6, 8 mm Wide x 300mm long
Standard Accessories
• Allen Wrench (3 mm) : 1 pc.
• Standard Accessories : 1 set
Exclusive Tools p.5-32

Code No.	Description	Package
64902	Abrasive Belt Width 4 mm #120	2 pcs. each
64904	Abrasive Belt Width 4 mm #240	
64906	Abrasive Belt Width 4 mm #400	
64912	Abrasive Belt Width 6 mm #120	
64914	Abrasive Belt Width 6 mm #240	
64916	Abrasive Belt Width 6 mm #400	
64922	Abrasive Belt Width 8 mm #120	
64924	Abrasive Belt Width 8 mm #240	
64926	Abrasive Belt Width 8 mm #400	

Air Line Kit

Code No. **4507** Model **AL-H1207F**



300(W) x 120(D) x 220(H) mm

This air line kit is designed for use with the AFC-45 Foot Controller, Code No.1064.

- Ensures a smooth operation and long life by supplying stable, conditioned air to the air motor.
- Three functions : air filter, regulator, mist lubricator can also be used to adjust motor speed.

◆ Weight : 2.2 kg ◆ Filter Mesh : 5 μm

Standard Accessories
• Air Pressure Gauge • Air Regulator • Air Filter • Lubricator
• Air Control Valve (CV-05) • Piping Hose (K-275) • Lubricating Oil (K-211)

MINI-LUSTER Attachment (Pencil-Type Reciprocating Polishing Finisher)

Code No. **1307** Model **ML-8** Stroke (0.8 mm)

Reciprocating motion

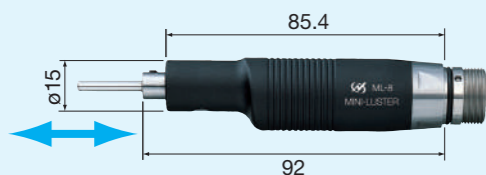

25,000 min⁻¹ Max.

- The pencil type grip is most suitable for polishing narrow grooves, details, etc.
- Stroke Range (Fixed) : 0.8 mm
- Reciprocating Stroke (Variable) : 0~6,380 times/min



◆ Weight : 130 g
◆ Max. tool shank diameter φ3.5 mm, Screw clamp type
Standard Accessories
• Allen Wrench (1.5 mm) : 1 pc.
• Standard Accessories : 1 set
Exclusive Tools p.5-19~22

Code No.	Description	Package
62751	Spring Holder	1 pc./pack
62510	Ceramic Fiber Grindstone Holder	
62814	Electroplated Diamond File 1.25 x 4 x 50 #100	
60520	Ceramic Fiber Grindstone 1 x 6 x 50 #1200	

LUSTER Attachment (Pistol-Type Polisher)

Code No. **1302** Model **LS-100**

Reciprocating motion



25,000 min⁻¹ Max.

- High performance grinding & polishing with high power and reciprocating stroke.
- Well-balanced, rubber-grip absorbs vibration.
- Stroke Range : 0~6 mm (variable)
- Reciprocating Stroke (variable) : 0~6,300 times/min



◆ Weight : 680 g
◆ Max. tool shank diameter φ6.4 mm, Screw clamp type
Standard Accessories
• Allen Wrench (2 mm), (3 mm) : 1 pc. each
• Lubricating Oil • Lubrication Nozzle for LUSTER
• Standard Accessories : 1 set
Exclusive Tools p.5-13~18

Code No.	Description	Package
62502	Stone Holder	1 pc./pack
62505	Stone Holder	
62751	Spring Holder	
62525	Rectangular Pad	
62526	Rod for Rectangular Pad	
62527	Angle Rod	10 pcs./pack
62552	Sand Paper Tip #120	
62555	Sand Paper Tip #320	
62557	Sand Paper Tip #600	
62559	Sand Paper Tip #1000	

1/4 Speed Reducer

Code No. **1009** Model **RG-01**



30,000 min⁻¹ Max.

- Mounted between an attachment and a motor.
- The speed is reduced to 1/4 while the torque is multiplied by 4 times.
- Suitable for high torque grinding process or drilling. ◆ Weight : 68 g

Standard Accessories
• Pin Wrench (K-233) : 1 pc.

1/15 Speed Reducer

Code No. **1010** Model **RG-02**



30,000 min⁻¹ Max.

- Mounted between an attachment and a motor.
- The speed is reduced to 1/15 while the torque is multiplied by 15 times.
- Suitable for high torque grinding process or drilling.

◆ Weight : 93 g

Standard Accessories
• Pin Wrench (K-233) : 1 pc.

Foot Controller

Code No. **1064** Model **AFC-45**



This Foot Controller is necessary for use with the AL-H1207F Air Line Kit.

- Designed to depress from any direction.
- Fine adjustment of speed control is possible.

Extension Joint

Code No. **1015** Model **CN-01**



35,000 min⁻¹ Max.

- Speed Ratio 1 : 1
- This is a joint to be connected between a motor and an attachment to extend the total length of the attachment.

◆ Weight : 83 g

Standard Accessories
• Pin Wrench (K-233) : 1 pc.

PRECISION PENCIL TYPE MICRO AIR GRINDER

IMPULSE Series

IMPULSE SERIES ◀◀

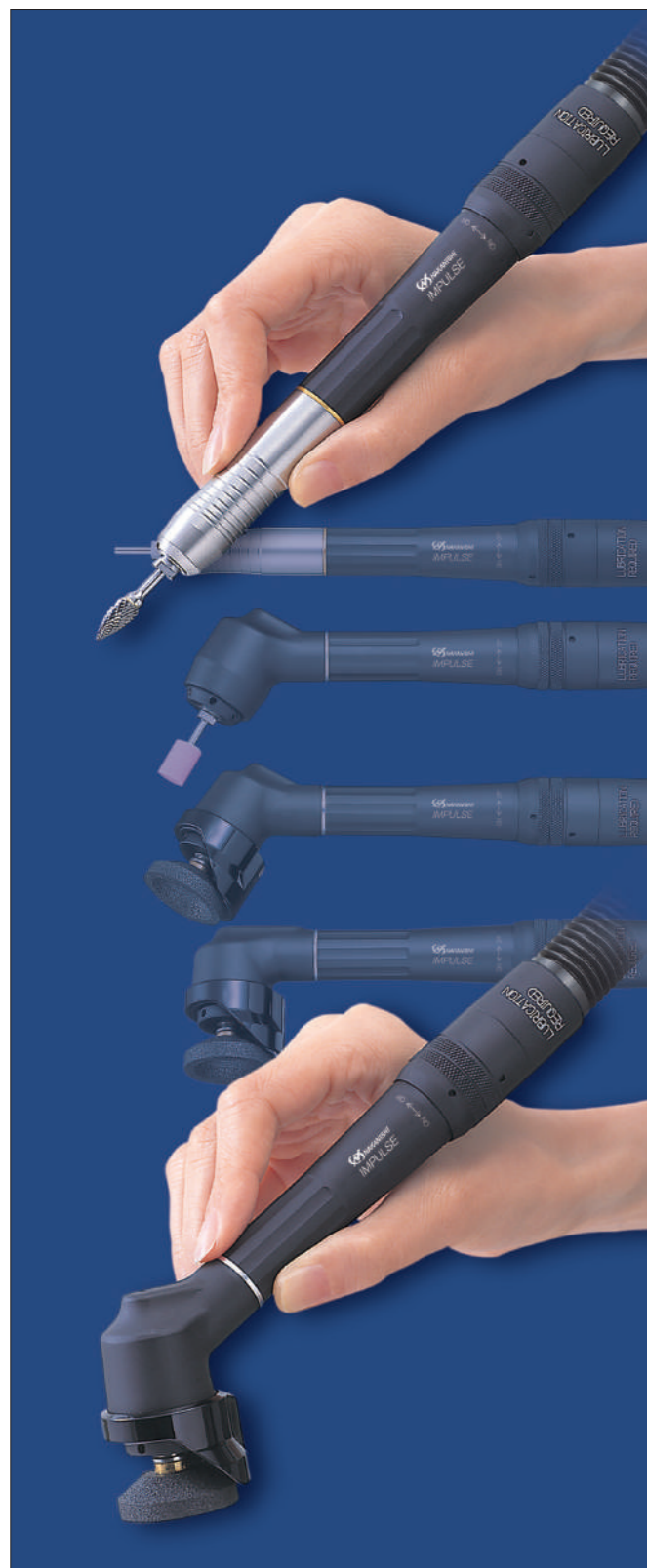
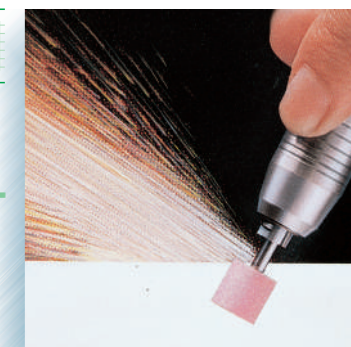

- ① 60,000 min⁻¹ NSP-601
- ② 40,000 min⁻¹ NA45-400 (60°)
- ③ 23,000 min⁻¹ NA45-230 (60°)
- ④ 23,000 min⁻¹ NA90-230 (90°)



- Precision and high accuracy
The smooth rotation without runout or vibration even at high speeds makes it ideal for precise microfabrication.
- High power and high torque
NAKANISHI air motors are equipped with a special vane motor. The rotation speed is maintained even under fluctuating grinding loads, ensuring stable grinding.
- Outstanding noise reduction
A silencer is attached to the end of exhaust hose as a standard.
- Excellent cost performance
The Impulse series offers excellent features at a very reasonable price.

Special Rotary Vane Air Motor

A special rotary vane air motor is used at the heart of the handpiece. The motor prevents the decrease in RPM that may occur due to processing load and maintains a stable grinding process.

Exchangeable Collet

Standard Size : $\phi 3.0$ mm (CHS-3.0)
Optional Collets : CHS Group $\phi 0.8$ ~ $\phi 3.175$ mm

Twist Free Hose

The grinder and dual hoses (air supply and exhaust) are not fixed, and the hoses swivel freely 360° without twisting. (IM-301)

60,000 min⁻¹



Straight IMPULSE		
Code No.	1034	Model NSP-601

ON / OFF Ring

Easy to switch ON / OFF and to adjust the motor speed, turning right & left.

Built-in Air Filter

Built in air filter in air inlet coupling (the connection to Air Line Kit).

Set-Up Drawing

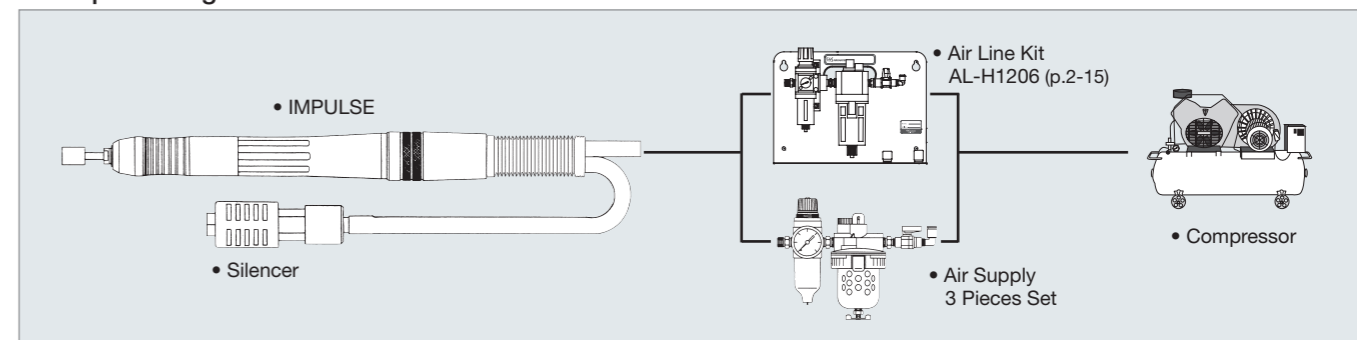

■ Use Air Line Kit AL-H1206 or air supply 3 pieces set. (Air Filter, Air Regulator, Lubricator)

IMPULSE AIR GRINDER ◀◀

PRECISION AIR GRINDER

Straight / 60° IMPULSE



Straight IMPULSE

60,000 min⁻¹

Code No.	1034
Model	NSP-601

Standard Size Collet

ø3.0 mm (CHS-3.0)

Optional Collets :
CHS Group are shown in page (p.4-4)



- Straight type is ideal for high speed precision grinding.
- The front part of the NSP-601 model is made of stainless steel ; the back portion of aluminum alloy.
- The safety design of clamping the chuck up to 29 mm maintains stable rotation of the cutting tool.
- The air motor is assembled with a special vane design which keeps constant speed under load providing stable grinding and polishing operation.

60° IMPULSE

40,000 min⁻¹

Code No.	1035
Model	NA45-400

Standard Size Collet

ø3.0 mm (CHS-3.0)

Optional Collets :
CHS Group are shown in page (p.4-4)



- Angle model's housing are made of aluminum alloy.
- Ideal for removing sharp edges at corners and surfaces difficult to reach with straight type handpieces.



Specifications

Air Consumption : 165 Nℓ /min
 Proper Air Pressure : 0.4~0.6 MPa
 Inlet Air Hose Length : 1.5 m
 Eraser Hose Length : 1.2 m

Standard Accessories

- Collet ø3.0 mm (CHS-3.0) : 1 pc.
- Mounted Point (42423) • Hose (K-213) : 1.5 m
- Silencer (K-208) : 1 pc. • Wrench (8 x 5) : 1 pc.
- Bar Wrench (K-212) : 1 pc.

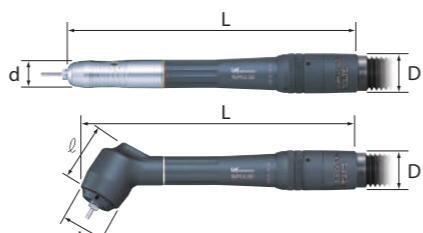

Code No.	d	D	ℓ	L	Weight	Speed	Collet
1034	ø17	ø23.9	—	168	165 g	60,000 min ⁻¹	ø0.8~ø3.175 mm
1035	ø28.6	ø23.9	39.6	161	210 g	40,000 min ⁻¹	CHS Group (p.4-4)

IMPULSE AIR GRINDER ◀◀

PRECISION AIR GRINDER

Super Cut IMPULSE



Exclusive Tools p.5-25~30

90° Super Cut IMPULSE

23,000 min⁻¹

Code No.	1036
Model	NA90-230

Standard Size Collet

ø3.0 mm (CHS-3.0)

Optional Collets :
CHS Group are shown in page (p.4-4)



Exclusive Tools p.5-25~30

Standard Accessories

Code No.	Description	Package
42423	Mounted Points	1 pc.
64822	Rubber Pad	1 pc./pack
64836	Cup Wheel	
64837	Cup Wheel	
64222	Sand Paper Disk ø31 #120	2 pcs./pack
64225	Sand Paper Disk ø31 #320	
64227	Sand Paper Disk ø31 #600	

▶ Disks → p.5-25~30



Please refer to next page.

60° Super Cut IMPULSE

23,000 min⁻¹

Code No.	1037
Model	NA45-230

Standard Size Collet

ø3.0 mm (CHS-3.0)

Optional Collets :
CHS Group are shown in page (p.4-4)



Exclusive Tools p.5-25~30

Standard Accessories

Code No.	Description	Package
42423	Mounted Points	1 pc.
64822	Rubber Pad	1 pc./pack
64836	Cup Wheel	
64837	Cup Wheel	
64222	Sand Paper Disk ø31 #120	2 pcs./pack
64225	Sand Paper Disk ø31 #320	
64227	Sand Paper Disk ø31 #600	

▶ Disks → p.5-25~30



Please refer to next page.



Specifications

Air Consumption : 165 Nℓ /min
 Proper Air Pressure : 0.4~0.6 MPa
 Inlet Air Hose Length : 1.5 m
 Eraser Hose Length : 1.2 m

Standard Accessories

- Grindstone Axis (NCH-01) : 1 pc.
- Silencer (K-208) : 1 pc. • Wrench (8 x 5) : 1 pc.
- Bar Wrench (K-212) : 2 pcs. • Hose (K-213) : 1.5 m
- Allen Wrench (1.5 mm) : 1 pc.

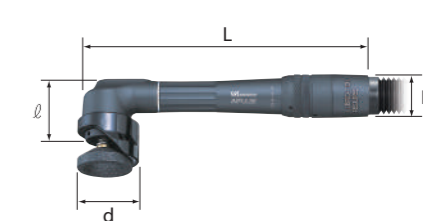

Code No.	d	D	ℓ	L	Weight	Speed	Collet
1036	ø33.5	ø23.9	34	156	190 g	23,000 min ⁻¹	ø0.8~ø3.175 mm
1037	ø33.5	ø23.9	39.6	163	190 g	23,000 min ⁻¹	CHS Group (p.4-4)

Air Line Kit (Automatic Lubricating Device)

Code No. **4506**

Model **AL-H1206**

- Standard Accessories**
- Air Pressure Gauge • Air Regulator
 - Air Filter • Lubricator
 - Air ON-OFF Valve
 - Piping Hose (K-275) : 2 m
 - Lubricating Oil (K-211) : 1 pc.



300(W) x 120(D) x 220(H) mm







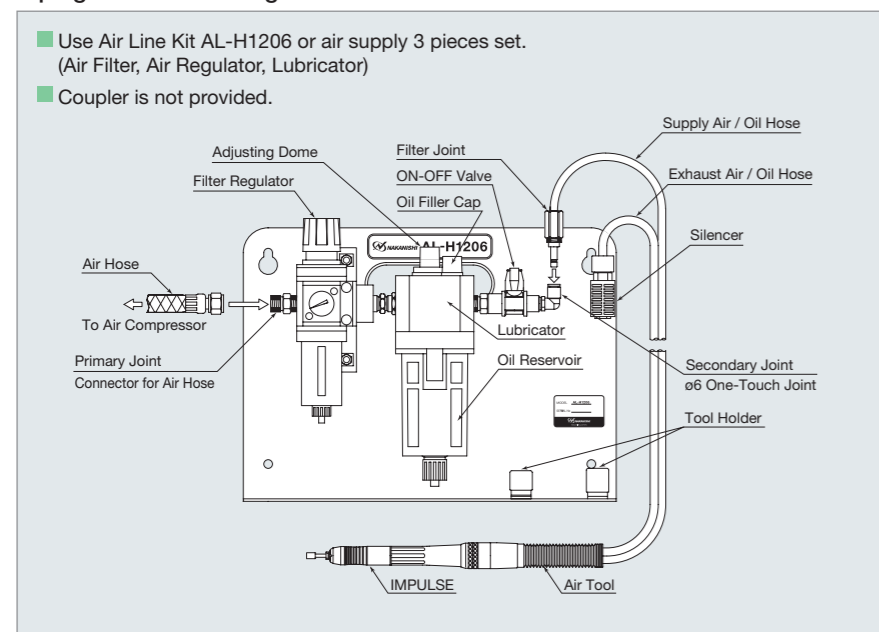



- Supplies a smooth air flow and automatic lubrication for long life and stable power.
- By adjustment of auto lubrication and air flow, this will help extend the life of air grinder.
- Best for grinding and polishing processes, AL-H1206 Air Line Kit has a compact body with a carrying handle and holder to put the IMPULSE in.

◆ Weight : 2.2 kg ◆ Filter Mesh : 5 μm

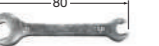
Piping Connection Diagram



IMPULSE Series Spare Parts

Product	Description	Code No.	Model	Fit to
	Grindstone Arbor (for Cup Wheel & Rubber Pad)	1045	NCH-01	IMPULSE
	Head Cover	1043	CNA	IMPULSE
	Hose 1.5 m	1038	K-213	IMPULSE
	Silencer Small (w/Metal Fittings)	1061	K-208	IMPULSE
	Wrench 8 x 5	2012	—	IMPULSE
	Bar Wrench (72 mm)	2013	K-212	IMPULSE
	Allen Wrench (1.5 mm)	—	—	IMPULSE Available in the market
	Lubricating Oil (70cc)	1057	K-211	For Air Line Kit AL-H1206
	Lubricating Oil (1ℓ)	1058	K-202	
	Filter Joint (for φ6 Quick Disconnecting Joint)	2039	FJ-02	(For K-213 Hose)

The Exchangeable Attachment Chart

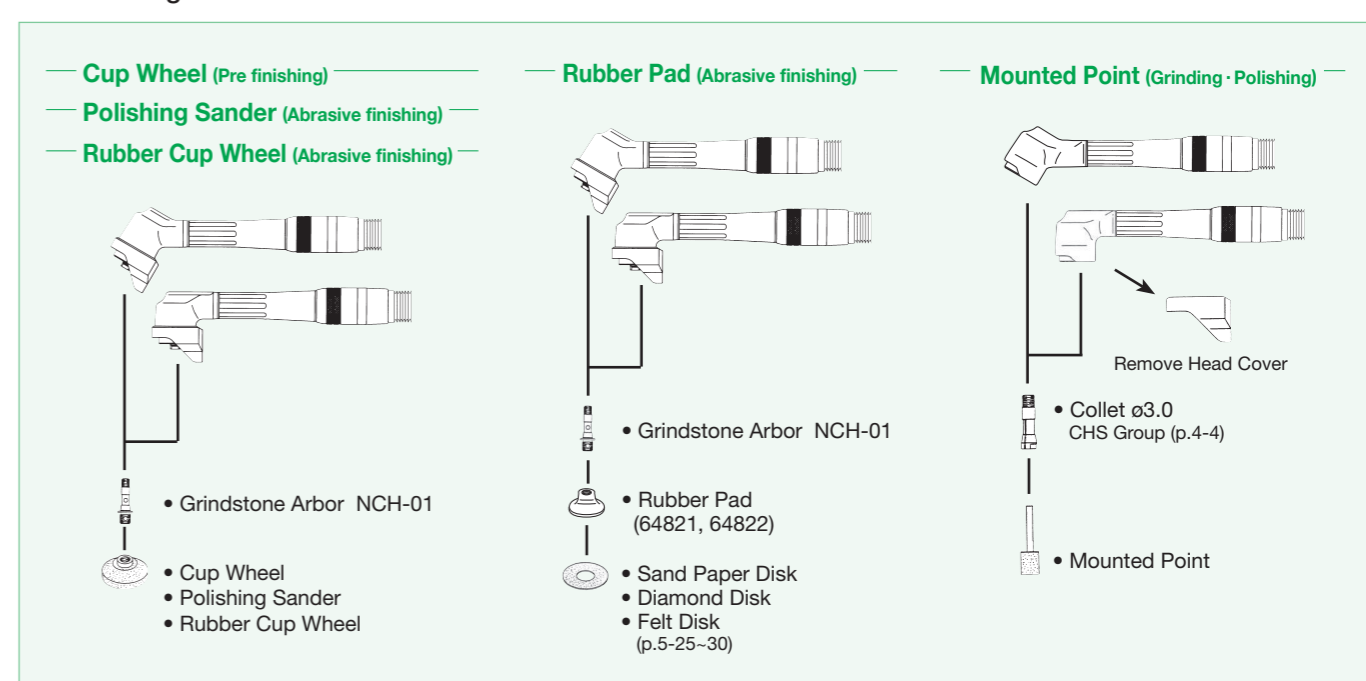

Rubber Pad

- Attach and use various types of polishing discs. (Refer to p.5-25~30)
- The elasticity of the rubber makes it ideal for finishing flat to curved surfaces.

5 per pack 23,000 min⁻¹ Max.

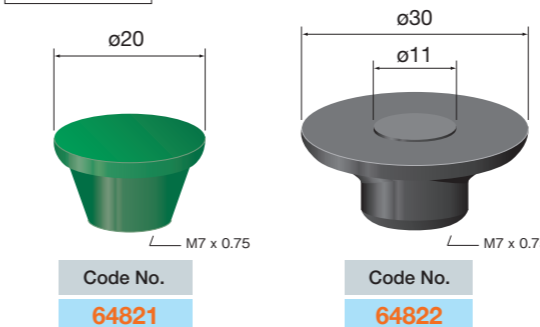

Flap Sanding Disc

- This is a sanding disc for high speed rotation with layered and bonded abrasive cloth.
- Compared to a grindstone, it has a softer bite for faster polishing.
- The overlapping abrasive cloths provide a new abrasive surface, resulting in excellent durability.

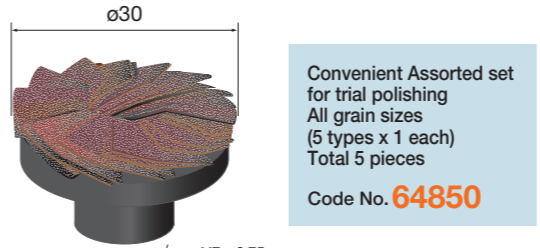

5 per pack 23,000 min⁻¹ Max.

Grit	Code No.
# 80	64842
# 120	64844
# 180	64846
# 240	64847
# 400	64849

Cup Wheel

Standard type Wheel height φ20...6 mm φ30...5 mm Overall height 10 mm

- A highly elastic grinding wheel with both grinding and polishing capabilities.
- It makes the most out of the high power of IMPULSE to machine flat and curved surfaces with high efficiency and softness.
- Compared with grinding wheels, there is no bite and the roughness of the finished surface can be finely adjusted.
- The use of a special bonding agent reduces clogging and allows the processing of a wide range of materials including general steel, aluminium, copper, brass and castings.

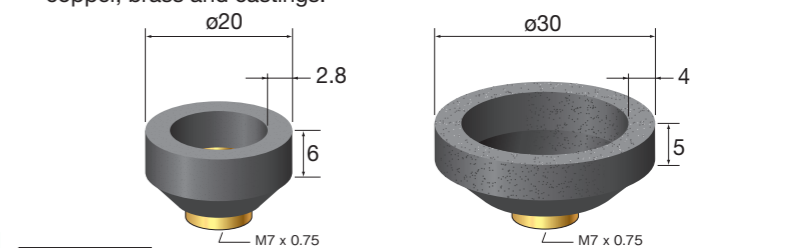

12 per pack 23,000 min⁻¹ Max.

Grit	Wheel hardness	Code No. (φ20)	Code No. (φ30)
#36	Standard	64830	64835
#46	Hard	64831	64836
#80	Standard	64832	64837
#80	Hard	—	64838

Thin long-life type

Wheel height 7.5 mm Overall height 10 mm Ideal for tight spaces and detail works.

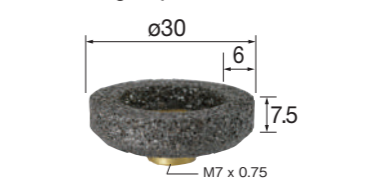

10 per pack 23,000 min⁻¹ Max.

Grit	Wheel hardness	Code No.
#36	Hard	64861
#46	Hard	64862
#80	Hard	64863

Long-life type

Wheel height 12 mm Overall height 14.5 mm 20% longer Wheel life than Standard type.



10 per pack 23,000 min⁻¹ Max.

Grit	Wheel hardness	Code No.
#36	Hard	64865
#46	Hard	64866
#80	Hard	64867

Rubber Cup Wheel

- Highly elastic rubber grinding wheel with both grinding and polishing properties.
- Highly efficient machining of flat and curved surfaces with a soft touch utilizing the high power of IMPULSE.
- Compared with grinding wheels, the impulse wheel does not bite and allows fine adjustment of roughness of finished surfaces.
- The use of a special bonding agent reduces clogging and enables machining of a wide range of materials, including general steel, aluminum, copper, brass, and castings.



NA90-230

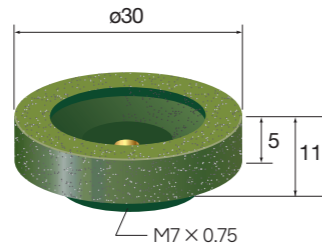

10 per pack 23,000 min⁻¹ Max.

Grit	Color	Code No.
# 60	Brown	64851
# 80	Red	64852
# 120	Blue	64853
# 180	Olive	64854
# 220	Green	64855
# 320	Brown	64856

Convenient Assorted set for trial polishing
All grain sizes (6 types x 2 each)
Total 12 pieces
Code No. **64859**

Welded Diamond Cup Wheel

Diamond abrasive grains are welded to the surface of the cup-shaped base under vacuum and high temperature conditions using a special alloy.

<6 Key Features> Cost saving and ecological benefits

- ① Significantly reduced dust generation and improved working environment. Generally, resinoid wheels generate a lot of dust due to their own wear and tear. This wheel does not generate any dust from itself.
- ② The large protrusion of diamond abrasive grains gives a sharp cutting edge and a much better cutting power.
- ③ The special welding method ensures strong diamond grain retention and excellent durability.
- ④ Greatly reduced sparks and odours during grinding.
- ⑤ No wear of the wheel itself and no change in the wheel's rim speed, resulting in a uniform surface.
- ⑥ Longer wheel life, less tool changes and less wasted machining time.

<Applications>

Suitable for grinding cast irons, castings, hard rubbers, FRP, stones, concretes and hard materials.

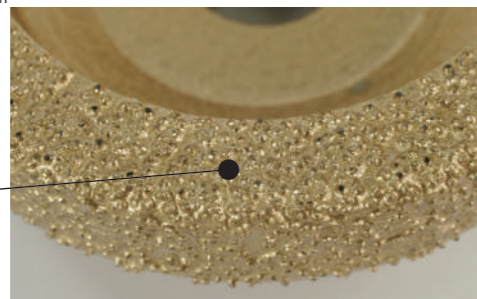
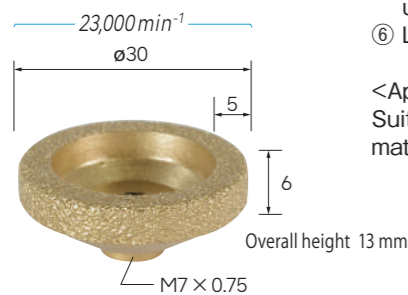

Enlarged photo of abrasive grains

1 per pack

Grit	Code No.
#60/#80	64871



PRESTO II AIR TURBINE GRINDER

ULTRA-HIGH SPEED AIR TURBINE GRINDER

PRESTO II

320,000 min⁻¹ ø1.6 mm Bur Only

- An astonishing 320,000 rpm. Smooth cutting without any resistance enables precise cutting and processing.
- Clean cutting is possible with the oilless air grinder. No oil sprays out to prevent the workpieces and hands from getting dirty.
- Lightweight aluminum body (71 g) with a palm-sized overall length (109 mm). High-precision processing of minute parts is possible at the same touch when holding a ball-point pen.

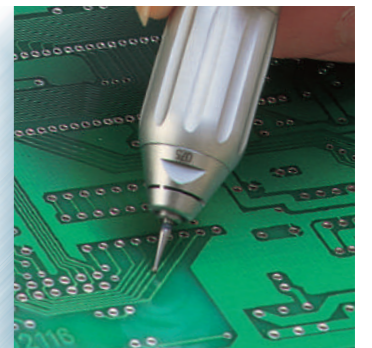

PRESTO II Standard Set

Code No. **1125**

Model **PRII-304S**

Standard Equipment

- Presto Handpiece (PR-304) : 1 pc.
- Air Line Kit (PRII-06) : 1 pc.
- Foot Controller (AFC-40) : 1 pc.
- Handpiece Holder (Z014) : 1 pc.



Specifications

Rotating Speed	: 320,000 min ⁻¹
Proper Air Pressure	: 0.25 MPa
Air Consumption	: 40 Nℓ/min
Inside Diameter	: ø1.6 mm Bur Only
Filter Mesh	: 5 μm

PRESTO Handpiece

320,000 min⁻¹

Code No. **1122**

Model **PR-304**

◆ Weight : 71 g (w/o Hose)

Standard Accessories

- 2 m Hose

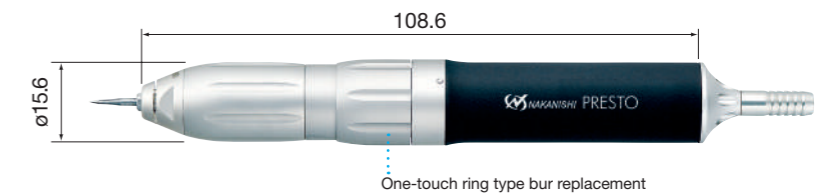

One-touch ring type bur replacement

- Ultra-high speed no lube air turbine handpiece ideal for delicate processing application.
- Built-in dust protection mechanism developed by NAKANISHI ensures long durability.
- Chip air blows away the cutting powder and cools the cutting tool.
- Flexible tubing ensures excellent workability reducing fatigue to the operator's hand for long continuous use.

PRESTO II Spare Parts

Product	Description / Specifications	Code No.	Model
	PRESTO II Air Line Kit (w/o Lubricator / Filter Mesh 5 μm)	1126	PRII-06
	PRESTO II Cartridge	1120	PR-03
	Foot Controller	1124	AFC-40
	Piping Hose (ø6.0) 2 m Long	2041	K-237
	Air Turbine Hose (ø5.1) 2 m Long	2042	K-238
	Pin Wrench	2002	T-751

ø1.6 mm tools for PRESTO II



Ultrasonic System Products

INDEX

▶▶▶ Sheenus ZERO Series

- Features p.3-3~4
- Set Products p.3-5
- Controllers / Handpiece / Parts p.3-6



Ultrasonic Polisher

▶▶▶ Sonic Cutter ZERO Series

- Features p.3-7~8
- Set Products p.3-9
- Controllers / Handpiece / Parts p.3-10



Ultrasonic Cutter

CAUTION

Electric System

Air System

Ultrasonic

General Parts

Exclusive Tools

CAUTION

Electric System

Air System

Ultrasonic

General Parts

Exclusive Tools

Sheenus ZERO

Ultrasonic Polisher



"ZERO magic" Achieve ZERO burden in polishing operations

Sheenus ZERO Series

High-speed polishing system using ultrasonic vibrations of 19,000 to 29,000 times per second with a maximum amplitude of 40 μ m. Vibration is not conveyed to the hand, and safety is further improved with high efficiency through circuit optimization and a heat generation protection function.

Improved visibility

The digital LED display on the controller clearly shows the status of the operating function. The Blue LED on the handpiece will indicate whether the power is ON or OFF.

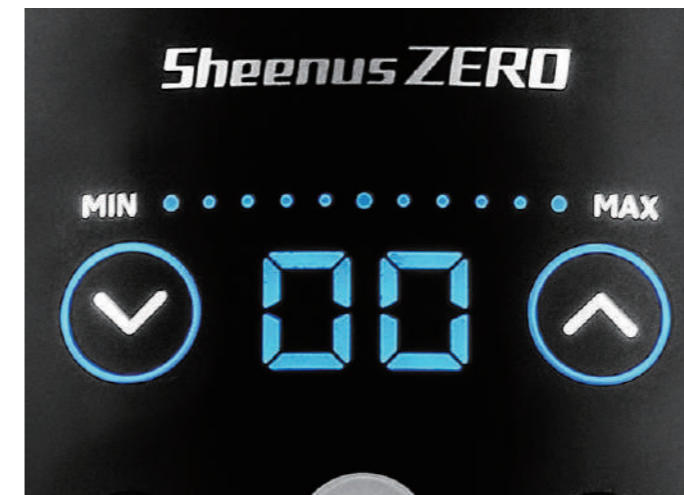

Improved energy savings

Rated power consumption is reduced by 13 % compared to the previous model.
(SHEENUS neo : 31 W → Sheenus ZERO : 27 W)

High efficiency power

Transmission efficiency has been improved by 16 % at maximum compared to the previous model.

Light weight

The weight of the controller has been reduced by 29 % compared to the previous model.
(SHEENUS neo : 2.1 kg → Sheenus ZERO : 1.5 kg)
Allows ease to carry around.

Heat protection function

Sheenus ZERO automatically suppresses the output and keeps the temperatures from rising to allow for continuous use.

- Adapted the worldwide power supply, 100 - 240V
- High-frequency noise is reduced by a sine wave drive.

CAUTION

Electric System

Air System

Ultrasonic

General Parts

Exclusive Tools

CAUTION

Electric System

Air System

Ultrasonic

General Parts

Exclusive Tools

ULTRASONIC POLISHER

Sheenus ZERO Set

- Sheenus ZERO can be used for grinding, polishing and mirror finishing on a wide range of materials from aluminum dies to cemented carbide dies. It is also perfect for plastic molds, press, casting, forging, trimming and header dies.
- This tool quickly removes hard layers of EDM deposits and polishes difficult areas such as complex corners and ribs.
- Capabilities include deburring, grinding and polishing of precision molds, dies electronic and ceramic components.



Code No.	7775	Model	US-50P Set 120V
Code No.	7776	Model	US-50P Set 230V

※Adapted the worldwide power supply, 100 - 240V.
Please choose the plug type of main power cord.

Standard equipment

- Controller : 1 pc.
- Handpiece : 1 pc.
- Tool box (Plastic) : 1 pc.
- Wrench (10 mm) : 2 pcs.
- Hexagon wrench (2.5 mm) : 1 pc.
- Foot switch (FC-24) : 1 pc.
- Spare fuse (T1.6AH 250V) : 2 pcs.
- Main power cord (2 m) : 1 pc.
(Plug type : 120V or 230V)

- Tools : 1set
- #60101 Electroplated diamond file (#200, Flat taper, 4 x 50 mm, t=0.4) : 1 pc.
- #60519 Ceramic fiber grindstone (#800, Flat, 6 x 50 mm, t=1.0) : 1 pc.
- #60902 Tip holder (For round, ø 3.0 tip) : 1 pc.
- #60922 Tip holder (For flat, t=1.0 tip) : 1 pc.



Sheenus ZERO

SERIES ◀◀

Sheenus ZERO Controller

- Powerful
Max. output power is 45 W.
- Digital Display
The LED display can be switched between the amplitude and WATT.
- Safety
The heat protection function can be set to detect abnormal heat.

Specifications

Oscillation frequency : 19 kHz - 29 kHz
Frequency control: Auto-tracking system
Outputs : 45 W (max.) UNCLAMP mode
20 W (max.) CLAMP mode
Output adjustment : 21 steps variable
Rated input : AC 100 - 240V
Rated power consumption : 27W
Dimensions : W161 x D256 x H84 mm
Weight : 1.5 kg

Standard accessories

- Spare fuse (T1.6AH 250V) : 2 pcs.
- Main power cord (2 m) : 1 pc.
(Plug type: 120V or 230V)

Code No.	7778	Model	Sheenus ZERO CONTROLLER 120V
Code No.	7779	Model	Sheenus ZERO CONTROLLER 230V

※Adapted the worldwide power supply, 100 - 240V.
Please choose the plug type of main power cord.



- A Power level indicator
- B Indicator (Display the amplitude, WATT and ERROR)
- C UP key / DOWN key
- D ERROR / WATT
- E ON / OFF key (Start and stop the handpiece)
- F CLAMP key
- G Main power switch
- H UNCLAMP key

Handpiece can be placed on the controller.

⚠ Sheenus ZERO is not compatible with SHEENUS neo.

Sheenus ZERO Handpiece

Exclusive Tools p.5-5~ 12

- Comfortable Usability
Light weight, ergonomically designed resin body enables effortless, precision work over long periods of time.
- Easy Tool Installation
Easy tool installation using wrenches.

Specifications

Oscillator : PZT piezoelectric type
Attachment fixing: M6 x P0.9 screw
Cord length : 3 m
Dimensions : Max. ø 28 x L 134 mm
Weight : 140 g (excluding cable)

Exclusive Tools p.5-5~ 12

Code No.	7780	Model	US-50P
----------	-------------	-------	---------------

※Tip holder and ceramic fiber grindstone in this picture are not provided when only handpiece is purchased.
NAKANISHI genuine tools are highly recommended.



⚠ Sheenus ZERO is not compatible with SHEENUS neo.

Sheenus ZERO Spare Parts

Product	Code No.	Description
	8103	FC-24 Foot switch (ON / OFF switch only)
	—	Wrench 10 mm Available in the market
	—	Hexagon wrench 2.5 mm Available in the market

Sonic Cutter ZERO



"ZERO Stress" Complex shapes can be created as desired.

Sonic Cutter ZERO Series

Sonic Cutter ZERO is a high performance cutter applying ultrasonic vibration at a rate of 38,000 - 40,000 times per second. The easy to maneuver razor sharp cutting edge enables delicate work even on complicated shaped objects. Ultrasonic vibration provides a sleek and precise finish.

Improved visibility

The digital LED display on the controller clearly shows the status of the operating function. The Green LED on the handpiece will indicate whether the power is ON or OFF.

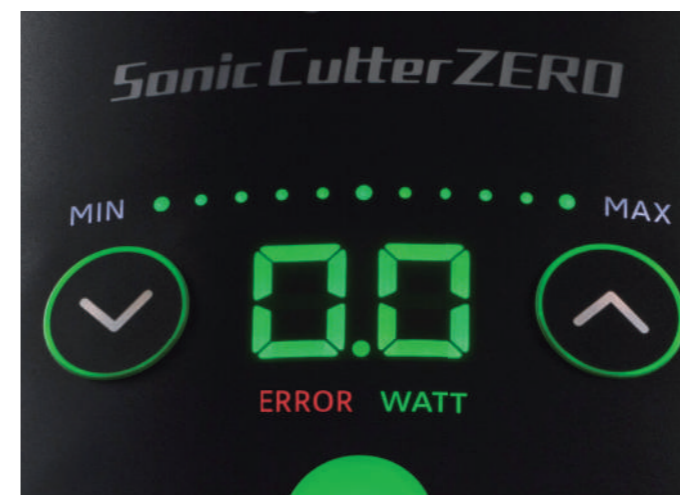

Lighter weight

The weight of the controller has been reduced by 46 % compared to the previous model. (Sonic Cutter: 2.6 kg → Sonic Cutter ZERO : 1.4 kg)

Reduction of heat level in handpiece

Improvements in the transducer achieved a lower heat level by 28.6 degrees Celsius maximum compared to the previous model.

Overheat protection function

The overheat protection function enables continuous use. When a specified temperature is detected, the output will be automatically adjusted to suppress the temperature from rising. If the excessive heat is detected, the controller will stop operating for safety.

■ Adapted the worldwide power supply, 100 - 240V

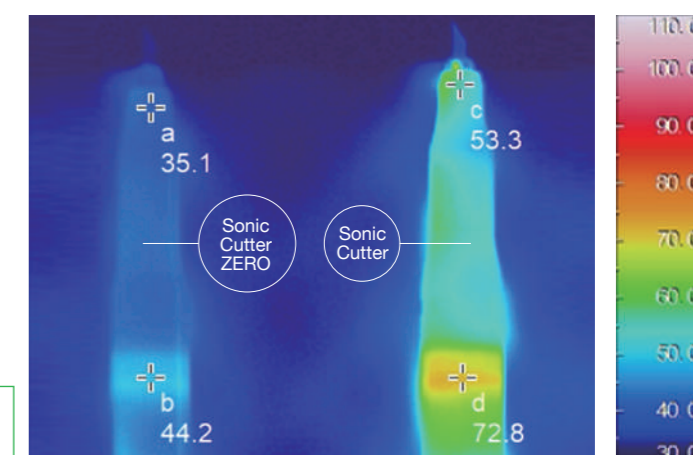

CAUTION
Electric System
Air System
Ultrasonic
General Parts
Exclusive Tools

CAUTION
Electric System
Air System
Ultrasonic
General Parts
Exclusive Tools

ULTRA-SONIC CUTTER

Sonic Cutter ZERO Set

- Especially effective for cutting complicated and precise shaping.
(For cutting fabrics, latex, films, plastics, urethanes and PCB pattern retouching, etc.)
- Efficient for cutting, clipping and deburring of various thin materials.
- An accurate and sharp cut can be ensured as there are no annoying vibrations felt on the handpiece.



Standard equipment

- Controller : 1 pc.
- Handpiece : 1 pc.
- Spare blades (BDC-200P 30°) : 40 pcs.
- Hexagon wrench (2 mm) : 2 pcs.
- Spare set screws (M4 x P0.7 x L4) : 4 pcs.
- Spare fuse (T1.6AH 250V) : 2 pcs.
- O-ring : 1 pc.
- Main power cord (2 m) : 1 pc.
(Plug type: 120V or 230V)

Code No.	7782	Model	US-40C Set 120V
Code No.	7783	Model	US-40C Set 230V

※Adapted the worldwide power supply, 100 - 240V.
Please choose the plug type of main power supply cord.

Sonic Cutter ZERO SERIES

Sonic Cutter ZERO Controller

- Oscillation frequency 38 kHz - 40 kHz and Max. output power 30 W achieves powerful cutting.
- A digital LED display indicates the watt and amplitude level clearly.
- LED display enhances visibility and prevention of misoperation.
- Heat protection function is equipped for a higher level of safety.

Specifications

Oscillation frequency : 38 kHz - 40 kHz
 Frequency control : Auto-tracking system
 Outputs : 30 W
 Output adjustment : 21 steps variable
 Rated input : AC 100 - 240V
 Dimensions : W161 x D256 x H84 mm
 Weight : 1.4 kg

Standard accessories

- Spare fuse (T1.6AH 250V) : 2 pcs.
- Main power cord (2 m) : 1 pc.
(Plug type : 120V or 230V)



- A Power level indicator
- B Indicator (Display the amplitude, WATT and ERROR)
- C UP key / DOWN key
- D ERROR / WATT
- E ON / OFF key (Start and stop the handpiece)
- F Main power switch



⚠ Sonic Cutter ZERO is not compatible with Sonic Cutter.

Code No.	7785	Model	Sonic Cutter ZERO CONTROLLER 120V
Code No.	7786	Model	Sonic Cutter ZERO CONTROLLER 230V

※Adapted the worldwide power supply, 100 - 240V.
Please choose the plug type of main power supply cord.

Sonic Cutter ZERO Handpiece

- The vibration is not transmitted to the users' hand to enable a desired cutting result.
- Heat protection function enables continuous use without any concerns of overheating.
- Sonic Cutter ZERO handpiece performs sharp cutting and makes beautiful cutting surface.

Specifications

Oscillator : Bolt-clamped Langevin type
 Setting the blade : screwed the blade
 W4 mm x thickness 0.38 mm
 Length of cord : 3 m
 Dimensions : Max. ø 25 x L166 mm
 Weight : 120 g (excluding cable)

Standard accessories

- Spare blades (BDC-200P 30°) : 40 pcs.
- Hexagon wrench (2 mm) : 2 pcs.
- Spare set screws (M4 x P0.7 x L4) : 4 pcs.
- O-ring : 1 pc.

Code No.	7787	Model	US-40C
----------	-------------	-------	---------------



⚠ Sonic Cutter ZERO is not compatible with Sonic Cutter.

Sonic Cutter ZERO Spare Parts

Product	Code No.	Description
	8103	FC-24 Foot switch (ON / OFF switch only)
	BDC-200P	Spare Blade Made by NT Incorporated Spare blade is available at a shop near you.

General Parts

INDEX

Collets p.4-3~4

CHC	CHG	CHH	CHM
CHS	K-252	K-253	

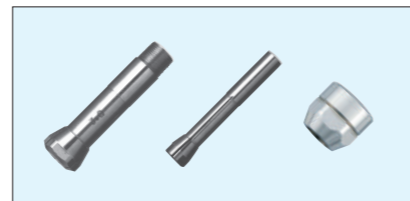

Motors · Motor Cords · Power Supply Cords p.4-5~6

Foot Pedals · Handpiece Stand etc. p.4-7

Head Cover, Carbon Brush



PRESTO II · FINE BELT SANDER Parts p.4-7

Oil p.4-8



Air Line Kits p.4-8



Hoses · Filter Joints p.4-8



Grindstone Arbor p.4-8



Wrenches p.4-9

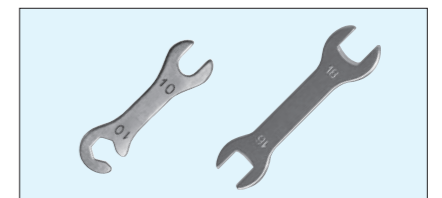

Silencers p.4-9

Protective Equipments p.4-10

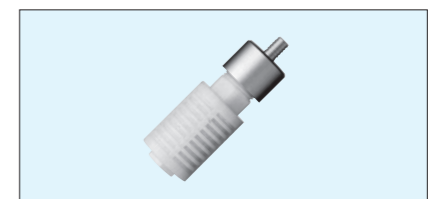

CAUTION

Electric System

Air System

Ultrasonic

General Parts

Exclusive Tools

CAUTION

Electric System

Air System

Ultrasonic

General Parts

Exclusive Tools

CHG Group

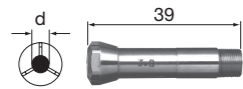

Fit to
HG-200 · EHG-400

Code No.	Model	I.D.
91105	CHG-0.5	φ0.5
91106	CHG-0.6	φ0.6
91107	CHG-0.7	φ0.7
91108	CHG-0.8	φ0.8
91109	CHG-0.9	φ0.9
91110	CHG-1.0	φ1.0
91111	CHG-1.1	φ1.1
91112	CHG-1.2	φ1.2
91113	CHG-1.3	φ1.3
91114	CHG-1.4	φ1.4
91115	CHG-1.5	φ1.5
91116	CHG-1.6	φ1.6
91117	CHG-1.7	φ1.7
91118	CHG-1.8	φ1.8
91119	CHG-1.9	φ1.9
91120	CHG-2.0	φ2.0
91121	CHG-2.1	φ2.1
91122	CHG-2.2	φ2.2
91123	CHG-2.3	φ2.3
91124	CHG-2.4	φ2.4
91125	CHG-2.5	φ2.5
91126	CHG-2.6	φ2.6
91127	CHG-2.7	φ2.7
91128	CHG-2.8	φ2.8
91129	CHG-2.9	φ2.9
91130	CHG-3.0	φ3.0
91131	CHG-3.1	φ3.1
91132	CHG-3.2	φ3.2
91133	CHG-3.3	φ3.3
91134	CHG-3.4	φ3.4
91135	CHG-3.5	φ3.5
91136	CHG-3.6	φ3.6
91137	CHG-3.7	φ3.7
91138	CHG-3.8	φ3.8
91139	CHG-3.9	φ3.9
91140	CHG-4.0	φ4.0
91141	CHG-4.1	φ4.1
91142	CHG-4.2	φ4.2
91143	CHG-4.3	φ4.3
91144	CHG-4.4	φ4.4
91145	CHG-4.5	φ4.5
91146	CHG-4.6	φ4.6
91147	CHG-4.7	φ4.7
91148	CHG-4.8	φ4.8
91149	CHG-4.9	φ4.9
91150	CHG-5.0	φ5.0
91151	CHG-5.1	φ5.1
91152	CHG-5.2	φ5.2
91153	CHG-5.3	φ5.3
91154	CHG-5.4	φ5.4
91155	CHG-5.5	φ5.5
91156	CHG-5.6	φ5.6
91157	CHG-5.7	φ5.7
91158	CHG-5.8	φ5.8
91159	CHG-5.9	φ5.9
91160	CHG-6.0	φ6.0
91190	CHG-0.73	φ0.73
91192	CHG-2.35	φ2.35
91193	CHG-3.175	φ3.175
91194	CHG-4.76	φ4.76
91196	CHG-6.35	φ6.35

CHC Group

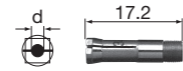

Fit to
IC-300 · KC-300 · EIC-300 · EKC-300

Code No.	Model	I.D.
90416	CHC-1.6	φ1.6
90492	CHC-2.35	φ2.35
90430	CHC-3.0	φ3.0
90493	CHC-3.175	φ3.175

CHH Group

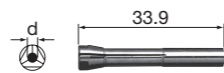

Fit to
IH-300 · IR-310 · EHR-500 · EHR-401 · EHL-401

Code No.	Model	I.D.
90603	CHH-0.3	φ0.3
90604	CHH-0.4	φ0.4
90605	CHH-0.5	φ0.5
90606	CHH-0.6	φ0.6
90607	CHH-0.7	φ0.7
90608	CHH-0.8	φ0.8
90609	CHH-0.9	φ0.9
90610	CHH-1.0	φ1.0
90611	CHH-1.1	φ1.1
90612	CHH-1.2	φ1.2
90613	CHH-1.3	φ1.3
90614	CHH-1.4	φ1.4
90615	CHH-1.5	φ1.5
90616	CHH-1.6	φ1.6
90617	CHH-1.7	φ1.7
90618	CHH-1.8	φ1.8
90619	CHH-1.9	φ1.9
90620	CHH-2.0	φ2.0
90621	CHH-2.1	φ2.1
90622	CHH-2.2	φ2.2
90623	CHH-2.3	φ2.3
90624	CHH-2.4	φ2.4
90625	CHH-2.5	φ2.5
90626	CHH-2.6	φ2.6
90627	CHH-2.7	φ2.7
90628	CHH-2.8	φ2.8
90629	CHH-2.9	φ2.9
90630	CHH-3.0	φ3.0
90692	CHH-2.35	φ2.35
90693	CHH-3.175	φ3.175

CHM Group



Fit to
BMH-300

Code No.	Model	I.D.
90910	CHM-1.0	φ1.0
90916	CHM-1.6	φ1.6
90920	CHM-2.0	φ2.0
90992	CHM-2.35	φ2.35
90930	CHM-3.0	φ3.0
90993	CHM-3.175	φ3.175

CHS Group

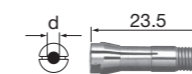

Fit to
ERA-270 · IMPULSE SERIES

Code No.	Model	I.D.
90508	CHS-0.8	φ0.8
90509	CHS-0.9	φ0.9
90510	CHS-1.0	φ1.0
90511	CHS-1.1	φ1.1
90512	CHS-1.2	φ1.2
90513	CHS-1.3	φ1.3
90514	CHS-1.4	φ1.4
90515	CHS-1.5	φ1.5
90516	CHS-1.6	φ1.6
90517	CHS-1.7	φ1.7
90518	CHS-1.8	φ1.8
90519	CHS-1.9	φ1.9
90520	CHS-2.0	φ2.0
90521	CHS-2.1	φ2.1
90522	CHS-2.2	φ2.2
90523	CHS-2.3	φ2.3
90592	CHS-2.35	φ2.35
90524	CHS-2.4	φ2.4
90525	CHS-2.5	φ2.5
90526	CHS-2.6	φ2.6
90527	CHS-2.7	φ2.7
90528	CHS-2.8	φ2.8
90529	CHS-2.9	φ2.9
90530	CHS-3.0	φ3.0
90593	CHS-3.175	φ3.175

K-252

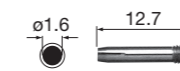

Fit to
MFC-300S

Code No.	Model	I.D.
90316	K-252	φ1.6

K-253

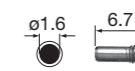

Fit to
MFC-300M

Code No.	Model	I.D.
90016	K-253	φ1.6

Emax EVOLution Motors

Product	Description	Code No.	Model	Fit to
	Standard Type Motor	8086	ENK-410S	Emax EVOLution NE249
	Torque Type Motor	8087	ENK-250T	Emax EVOLution NE249
	LUSTER	1483	NLS-110	Emax EVOLution NE249

Emax EVOLution Motor Cords

Product	Description	Code No.	Model	Fit to	Switch color
	Straight Cord : 1.5 m <with Switch>	8088	ENKCD-410S	ENK-410S (Standard Type Motor)	Blue
		8089	ENKCD-250T	ENK-250T (Torque Type Motor)	Green

ELECTER Emax Motors

Product	Description	Code No.	Model	Fit to
	Standard Type Motor	8003	NK-351	ELECTER E-max NE129
	Torque Type Motor	8012	NK-261	ELECTER E-max NE129

ELECTER Emax Motor Cords

Product	Description	Code No.	Model	Fit to	Switch color
	Coiled Cord : 1.5 m <with Switch>	8004	NCL-351C	NK-351 (Standard Type Motor)	Blue
		8013	NCL-261C	NK-261 (Torque Type Motor)	Green
	Straight Cord : 2 m <with Switch>	8005	NCL-351S	NK-351 (Standard Type Motor)	Blue
		8014	NCL-261S	NK-261 (Torque Type Motor)	Green
	Extension Straight Cord : 3 m	8051	NCL-EXT	ELECTER E-max Motor (All Kinds)	

EsPERT 500 Motor Cords

Product	Description	Code No.	Model	Fit to
	EsPERT 500 Compact Motor Cord	9093	ENKCD-50C	ENK-500C
	EsPERT 500 Torque Motor Cord	9094	ENKCD-50T	ENK-500T

Power Supply Cords

Plug Type	Main Usable Area	Product	Code No.	Model	Fit to Controller
For 100V (A type)	For Japan		1484	K-269	Emax EVOLution
			8057	U403013	ELECTER / ESPERT Sheenus ZERO / Sonic Cutter ZERO
For 120V (B type)	For U.S.A. and Canada		1485	U508013A001	Emax EVOLution
			7728	U166A013A	ELECTER / ESPERT Sheenus ZERO / Sonic Cutter ZERO
For 230V (D type)	For Europe		1486	U508014A	Emax EVOLution
			7729	U260414	ELECTER / ESPERT Sheenus ZERO / Sonic Cutter ZERO

CAUTION

Electric System

Air System

Ultrasonic

General Parts

Exclusive Tools

CAUTION

Electric System

Air System

Ultrasonic

General Parts

Exclusive Tools

■ Foot Pedals

Product	Description	Code No.	Model	Fit to
	Foot Controller ON-OFF and speed change can be accomplished.	8106	FC-64	Controller Emax EVOLution NE249
	Foot Pedal ON-OFF and speed change can be accomplished.	1440	FC-40	Controller ELECTER E-max NE129 · ESPERT 500 NE96
	Foot switch	8103	FC-24	Sheenus ZERO · Sonic Cutter ZERO
	Foot Controller	1064	AFC-45	ROTUS · Air Line Kit AL-H1207F
		1124	AFC-40	PRESTO II PRII-06

■ Handpiece Stand, Handpiece Holder & Head Cover

Product	Description	Code No.	Model	Fit to
	Handpiece Stand	8104	K-274	Emax EVOLution · ELECTER E-max · SHEENUS neo ESPERT 500
	Handpiece Holder	8107	K-273	Controller Emax EVOLution NE249
	Head Cover	1043	CNA	IMPULSE

■ Carbon Brushes (each 2 pcs.)

Product	Description	Code No.	Model	Fit to
	Carbon Brush	1424	E023011	NK-351 · NK-350 · NK-804T · NLS-100
		1425	E037011	NK-151 · NK-261 · NK-150 · ET II NK-260N

■ PRESTO II Parts

Product	Description	Code No.	Model	Fit to
	PRESTO II Cartridge	1120	PR-03	PRESTO II

■ FINE BELT SANDER Parts

Product	Description	Code No.	Model	Fit to
	Tension Pulley	1103	TP-12A	FINE BELT SANDER KBS-101 · EBS-101
	Tension Pulley Assembly	1104	TPA-12A	FINE BELT SANDER KBS-101 · EBS-101

■ Lubricating Oil

Product	Description	Code No.	Model	Fit to
	Lubricating Oil (70cc)	1057	K-211	Air Line Kit AL-H1206 · AL-H1207F
	Lubricating Oil (1 l)	1058	K-202	

■ Air Line Kits

Product	Description	Code No.	Model	Fit to
	Air Line Kit (ø6 joint / Filter Mesh 5 µm)	4506	AL-H1206	IMPULSE
	Air Line Kit (ø6 joint / Filter Mesh 5 µm)	4507	AL-H1207F	ROTUS ※ This air line kit is designed for use with the AFC-45 foot controller, Code No.1064 (p.4-7).
	PRESTO II Air Line Kit (w/o Lubricator / Filter Mesh 5 µm)	1126	PRII-06	PRESTO II

■ Hoses

Product	Description	Code No.	Model	Fit to
	Hose 2 m (INLET)	2027	K-206	ROTUS IM-301
	Hose 2 m (INLET, Chip Air Mechanism)	2020	K-207	ROTUS IM-300
	Hose 1.5 m	1038	K-213	IMPULSE
	Hose for Piping 2 m (ø6.0)	2041	K-237	PRESTO II
	Turbine Hose 2 m (ø5.1)	2042	K-238	PRESTO II
	Hose for Piping 2 m with Metal Fitting	2070	K-275	For Air Line Kit

■ Filter Joints

Product	Description	Code No.	Model	Fit to
	Filter Joint (for ø6 Quick Disconnecting Joint)	2038	FJ-01	(For K-206 Hose) (For K-207 Hose)
	Filter Joint (for ø6 Quick Disconnecting Joint)	2039	FJ-02	(For K-213 Hose)

■ Grindstone Arbor

Product	Description	Code No.	Model	Fit to
	Grindstone Arbor (for Cup Wheel & Rubber Pad)	1045	NCH-01	IMPULSE

CAUTION

Electric System

Air System

Ultrasonic

General Parts

Exclusive Tools

CAUTION

Electric System

Air System

Ultrasonic

General Parts

Exclusive Tools

■ Wrenches

Product	Description	Code No.	Model	Fit to
	Collet Wrench	2006	K-232	MFC-300S · MFC-300M
	Collet Wrench	2007	K-231	IC-300 · KC-300 · EIC-300 · EKC-300
	Wrench 4 x 7 (for K-231)	2068	—	IC-300 · KC-300 · EIC-300 · EKC-300
	Bar Wrench (72 mm)	2013	K-212	HG-200 · HA-500 · EHG-400 · IMPULSE
	Wrench 6 x 4.5	2001	—	BMH-300
	Wrench 7 x 5.1	2009	—	IH-300 · IR-310 · BMH-300 · EHR-500 · EHR-401 · EHL-401 · ERA-270
	Wrench 8 x 5	2012	—	ERA-270 · IMPULSE
	Wrench 10 x 10	2008	—	HG-200 · EHG-400
	Wrench 16 x 18 (Length 125 mm)	2047	—	SLS-16
	Wrench 20 x 24 (Length 150 mm)	2018	—	SLS-16 · EIC-300 · EKC-300 · ERA-270 · ECN-011
	Pin Wrench	2014	K-233	NK-351 · ENK-410S · IH-300 · IR-310 · HG-200 · BMH-300 · MFC-300S · MFC-300M · IC-300 · KC-300 · RG-01 · RG-02 · CN-01 · EHR-500 · EHL-401 · ERG-01B · ERG-01 · IM-301 · IM-300
	Pin Wrench	2002	T-751	PRESTO II
	Wrench with Handle (8 mm)	2016	K-248	Length : 104 mm
	Wrench with Handle (10 mm)	2017	K-249	Length : 105 mm
	L Shaped Wrench (9 mm)	2055	—	EHR-500 · IR-310 · IH-300
	Wrench (10 mm)	—	—	Sheenus ZERO
	Allen Wrench (1.5 mm)*	—	—	ML-8 · EML-8 · SLS-16 · IMPULSE
	Allen Wrench (2 mm)*	—	—	NLS-110 · LS-100 · NLS-100 · ELS-100 · Sonic Cutter ZERO
	Allen Wrench (2.5 mm)*	—	—	Sheenus ZERO
	Allen Wrench (3 mm)*	—	—	KBS-101 · NLS-110 · NLS-100 · LS-100 · ELS-100 · EBS-101

* Available in the market

■ Silencers

Product	Description	Code No.	Model	Fit to
	Silencer Large (with Metal Fitting)	1060	K-209	ROTUS
	Silencer Small (with Metal Fitting)	1061	K-208	IMPULSE

Protective Equipments

Always use safety glasses, mask, face guard for your safety.

Safety Eyewear

1 pack
1 pc.



Glasses Type

- Frame : Plastic
- Weight : 43 g

Code No.
69101



Goggles Type

- Frame : Soft vinyl
- Weight : 91 g

Code No.
69102

Face Shield

1 pack
1 pc.



Curved surface Type

- Lens : Acrylic resin
- Weight : 144 g

Code No.
69105



Flat surface Type

- Lens : Acetate resin
- Weight : 144 g

Code No.
69106

Disposable Dust-proof Mask

1 pack
5 pcs.



Dust-proof mask with exhaust valve

	Code No.
Head-mounted type	69112
Ear-mounted type	69115

LINE UP



① Exclusive Tools for Ultrasonic Polisher "Sheenus ZERO"



② Exclusive Tools for Electromotive Polisher "LUSTER"



③ Exclusive Tools for Electromotive Polisher "MINI-LUSTER"



④ Exclusive Tools for Electromotive Polisher "SWING-LUSTER"



⑤ Exclusive Tools for "ANGLE TYPE"



⑥ Exclusive Tools for "MINI-ANGLE TYPE"



⑦ Exclusive Tools for "FINE BELT SANDER"

NAKANISHI Exclusive Tools

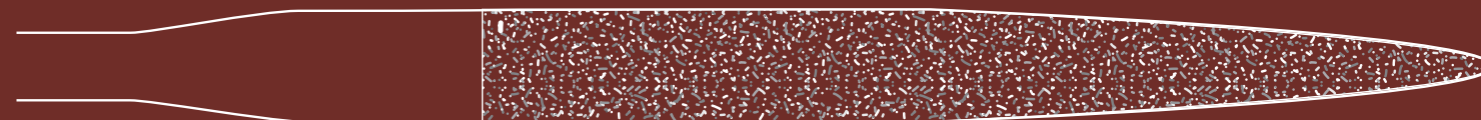

- ① Exclusive Tools for "Sheenus ZERO" p.5-5~12
- ② Exclusive Tools for "LUSTER" p.5-13~18
- ③ Exclusive Tools for "MINI-LUSTER" p.5-19~22
- ④ Exclusive Tools for "SWING-LUSTER" p.5-23~24
- ⑤ Exclusive Tools for "ANGLE TYPE" p.5-25~30
- ⑥ Exclusive Tools for "MINI-ANGLE TYPE" p.5-31
- ⑦ Exclusive Tools for "FINE BELT SANDER" p.5-32

CAUTION

Electric System

Air System

Ultrasonic

General Parts

Exclusive Tools

CAUTION

Electric System

Air System

Ultrasonic

General Parts

Exclusive Tools

The pages are organized by code number, so you can find the code number you need by checking the code numbers printed at the top of the left and right pages.

SHANK DIAMETER

SHANK $\phi 3.0$

Indicates the shank diameter of various types of shafted tools.

※ NAKANISHI micro grinders use a collet system to maintain high precision. Please prepare a collet that corresponds to each shank diameter.

Grit Size (Mesh Size)

#180

This indicates the size (roughness) of the abrasive grains used in various types of polishing / grinding materials. The larger the number, the smaller (finer) the grit size, and conversely, the smaller the number, the larger (coarser) the grit size (roughness). This is the most significant factor that affects the roughness of the finished surface.

- Rough Finishing 46, 54, 60, 70, 80, 90
- Pre Finishing 100, 120, 150, 180
- Middle Finishing 220, 240, 280, 320, 400
- Finishing 500, 600, 700, 800, 1000
- Extra Fine to Mirror Finishes 1200, 1500, 1800, 2000, 3000, 4000, 6000, 8000...

Maximum Allowable Speed

30,000 min⁻¹

Do not exceed the maximum allowable speed. For safety reasons, always use below the indicated allowable speed.

If this is the first time you are using the equipment or tip tool, start with a low speed and gradually increase it to reach the most appropriate speed for use.

Conditions may vary depending on the type, shape, overall length, and wear condition of the tip tool, so please work with constant care.

※ The maximum allowable operating speed is for when the overhang is under 10 mm. If the overhang is more than 10 mm, please reduce the speed.

For details, please refer to "Precautions for use" on page A-3~4.

※ Make sure there are no mechanical defects in the equipment prior to each use.

Actual size illustration (excluding some tools and overall length)

Shank diameter of the tools listed on the facing page

The beginning of the Code Numbers listed on the facing page. (The last number listed is found on the right side.)

Quantity in Standard Package

1 pc./pack

A standard package is the minimum shipping unit. This number shows the number of pieces in the standard package (bag, box, etc.). Please order the number of packages needed for the desired quantity.

11131~

**Angle Type Grinder
(Electric / Pneumatic)**
Exclusive Tools for "MINI ANGLE Type"

NAKANISHI Angle Grinders are available with a wide range of tools for a variety of machining operations, from cutting to grinding, polishing and lapping.

SHANK DIAMETER

SHANK $\phi 1.6$

MINI Angle Type

Diamond Burs for Deep Hole Chamfering

SHANK $\phi 1.6$ 1 pc./pack Diamond Burs for Deep Hole Chamfering

- Ideal for machining hardened steel, cemented carbide, ceramics, etc.

Diamond abrasive grains

11131

11132

11133

SHANK $\phi 1.6$ 1 pc./pack

Diamond Burs for Deep Hole Chamfering

Diamond abrasive grains

11151

11152

11153

11154

11155

11156

Tools of $\phi 1.6$ mm shank

Diamond Burs

Carbide Burs

Mounted Abrasive Points

Abrasive Rubber Points

P.5-31

Photograph of the basic shape

Maximum Allowable Speed
Grit Size

Overall length

Code No. (Order Number)

Note : Specifications may change without notice. The color of the tools in the catalog may differ from the actual color due to printing and other factors.

These tools are specially designed for NAKANISHI's Ultrasonic Polishing System to achieve the ideal finish with powerful sonic vibrations. A wide variety of tools are available to meet all kinds of processing situations.

<Precautions for use>

Select the CLAMP / UNCLAMP mode according to the tool you are using.



- ★ Suitable for finishing of high-hardness metals such as mold steel (removal of hardened electroplated layer, etc.) and heat treated metal. Also suitable for polishing of cemented carbide molds, aluminum molds, and copper alloy molds.
- ★ Ideal for grinding and polishing fine parts and rib slits of various molds for plastics, press, forging, headers, die-casting, etc.
- ★ It can be used for grinding and polishing ceramics, precision electronic parts, and precision mechanical parts.
- ★ It can handle a wide range of processing, from grinding of complex shapes and minute parts to mirror-polished finishes.

Electroplated Diamond File

<Features>

- Diamond abrasive grains are electroplated to the file surface (electroplated coating).
- The electroplated type has the largest amount of protruding abrasive grains and offers excellent cutting performance.
- The life of the file is shorter than that of metal bonded files due to the single layer of diamond grains on the surface.
- It is suitable for processing ribs, corners, and holes because the shape of the file hardly changes.
- It is suitable for finishing of hard metal such as mold steel (removal of hardened electroplated layer, etc.) and heat treated metal. It is also suitable for polishing cemented carbide molds, aluminum and hard alloy molds.
- Suitable for grinding and polishing ceramics, precision electronic parts and precision mechanical parts.

※The diamond file part is brazed onto the holder, so the diamond file part cannot be replaced.

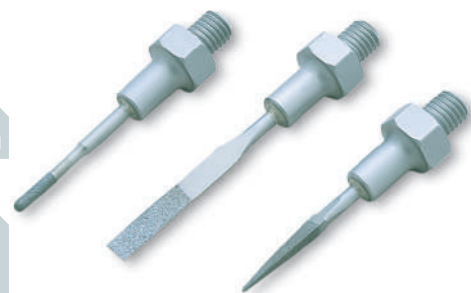

1 pc./pack Electroplated Diamond File The illustrations on this page are 90% of the actual size.

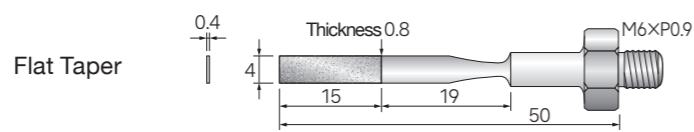

Grit Size	Code No.
#200	60101
#320	60102
#600	60103

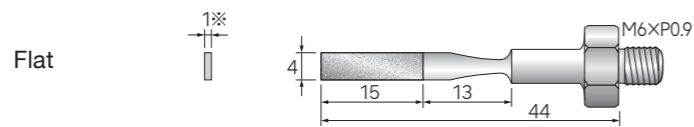

#200	60105
#320	60106
#600	60107

※Thickness of 60107 is 0.8 mm.

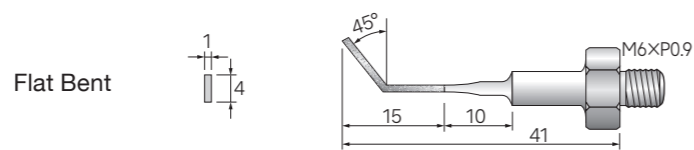

#200	60111
#320	60112
#600	60113

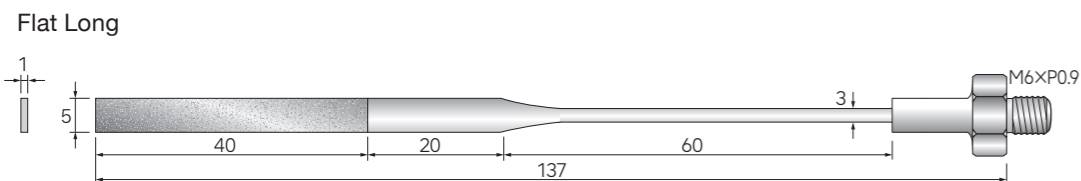

#200	60115
#320	60116
#600	60117

1 pc./pack Electroplated Diamond File The illustrations on this page are 90% of the actual size.

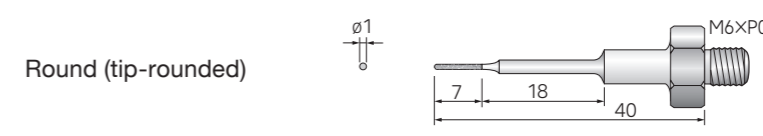

Grit Size	Code No.
#200	60151
#320	60152
#600	60153

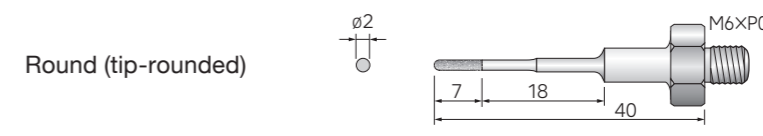

#200	60155
#320	60156
#600	60157

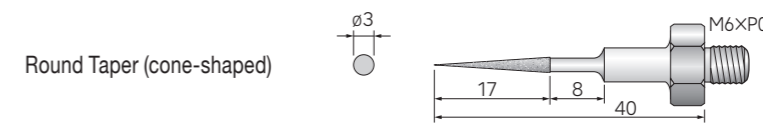

#200	60181
#320	60182
#600	60183

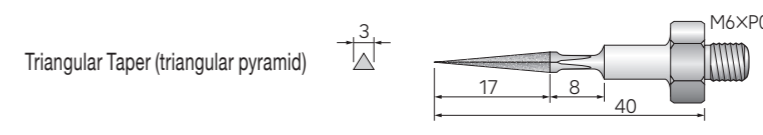

#200	60185
#320	60186
#600	60187

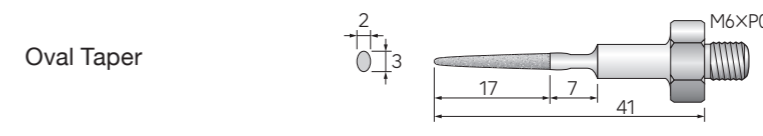

#200	60191
#320	60192
#600	60193

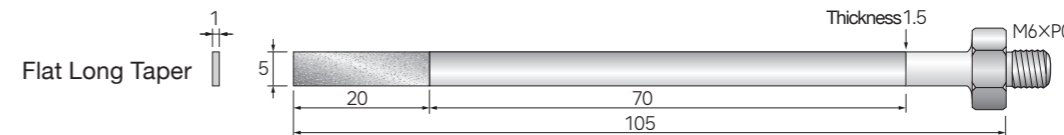

#200	60231
#320	60232
#600	60233

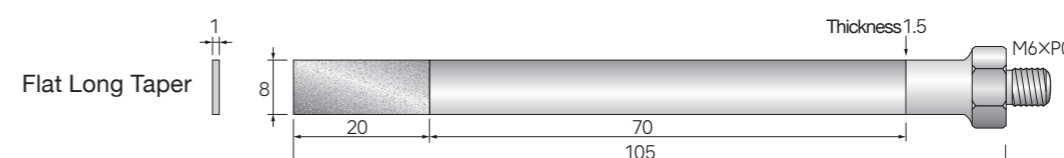

#200	60235
#320	60236
#600	60237

SHANK DIAMETER



These tools are specially designed for NAKANISHI's Ultrasonic Polishing System to achieve the ideal finish with powerful sonic vibrations. A wide variety of tools are available to meet all kinds of processing situations.

<Precautions for use>

Select the CLAMP / UNCLAMP mode according to the tool you are using.



Ultrasonic Polisher
Sheenus ZERO

Electroplated Diamond File



- <Features>
- Diamond abrasive grains are electroplated to the file surface (electroplated coating).
 - The amount of protruding diamond grains is large, and the cutting performance is excellent.
 - We use carefully selected diamond abrasive grains and electroplate them particularly strongly for machine finishing, so they have excellent durability. It has excellent durability.
 - It is suitable for finishing of high-hardness metals such as mold steel, heat treated metal, cemented carbide, and ceramics, polishing and finishing of various molds, and deburring and correction of machine parts.

SHANK Ø3.0 1 pc./pack Electroplated Diamond File

Flat Taper



Grit Size	Code No.
#200	62301
#400	62302
#600	62303

Flat Taper

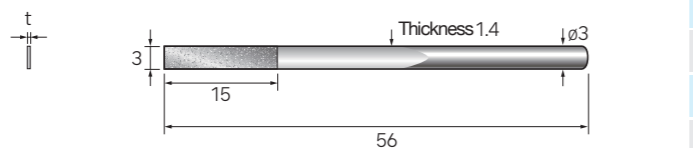

Thickness (t)	Grit Size	Code No.
0.5	#200	62801
0.4	#400	62802
0.35	#600	62803

Flat Taper

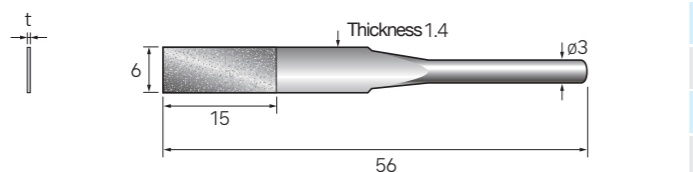

Thickness (t)	Grit Size	Code No.
0.5	#200	62805
0.4	#400	62806
0.35	#600	62807

Flat

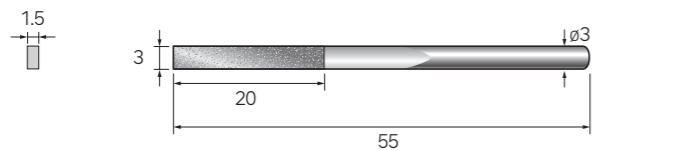

#150	62811
#200	62812
#400	62813

Flat
(Single Side Electroplated)

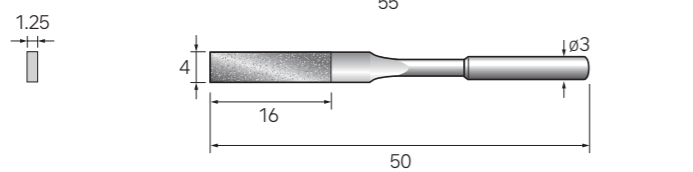

#100	62814
------	-------

Flat

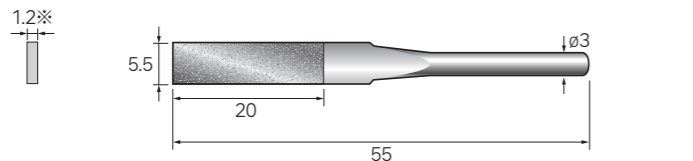

#150	62815
#200	62816
#400	62817

※ Thickness of 62815 is 1.4 mm.

Flat
(Single Side Electroplated)

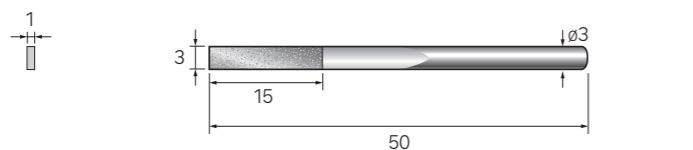

#150	62821
#200	62822
#400	62823

Flat
(Single Side Electroplated)

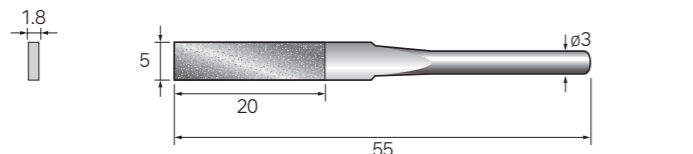

#150	62825
#200	62826
#400	62827

SHANK Ø3.0 1 pc./pack Electroplated Diamond File

Round

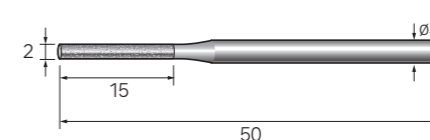

Grit Size	Code No.
#150	62845
#200	62846
#400	62847

Half Round

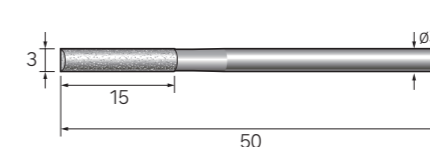

#150	62865
#200	62866
#400	62867

Half Round

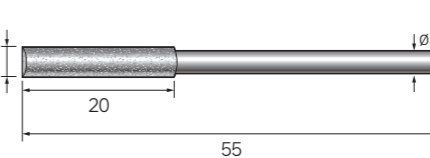

#150	62871
#200	62872
#400	62873

Triangular

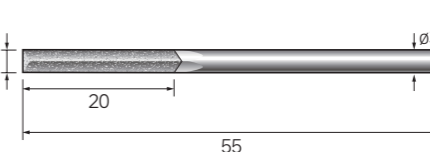

#150	62881
#200	62882
#400	62883

2 pcs./pack

Special Tip Holder



Round

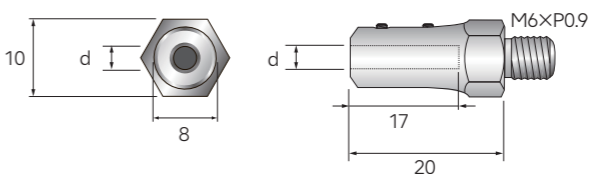

Diameter (d)	Code No.
Ø2.0	60911
Ø3.0	60912
Ø3.2	60913

Attach various round bar type tips (lapping brass tips, electroplated diamond files). Suitable for hard materials.

About Exclusive Tools for Sheenus ZERO

Highly efficient processing is realized by the tool which vibrates (longitudinal direction) at an ultrasonic speed of 22,500 times per second (22.5KHz).

Unlike mechanical vibration, the amplitude is extremely small (40µ) and the operator does not feel the vibration.

Principle: Each tool has its own natural frequency. When the ultrasonic vibration frequency matches that of the tool, the tool resonates significantly. This resonant state is maintained in a stable manner and is used as a processing force.

※ As the ultrasonic vibration and tool's resonant frequency must synchronize, commercially available NON-NAKANISHI genuine files and other abrasive tools may not properly vibrate. Please note that the length, thickness, material, density, weight, shape, etc. of the tool will affect the results.

These tools are specially designed for NAKANISHI's Ultrasonic Polishing System to achieve the ideal finish with powerful sonic vibrations. A wide variety of tools are available to meet all kinds of processing situations.

<Precautions for use>
Select the CLAMP / UNCLAMP mode according to the tool you are using.



Ceramic Fiber Grindstone Tip

A ceramic fiber grindstone with both intensity and flexibility developed for finish polishing.

<Features>

- Its softness and sharpness make it possible to perform finishing with a comfort, not possible with conventional grindstones.
- Its elasticity makes it difficult to break despite its thinness, and its good grip on the surface makes it easy to work with and use.
- It provides a smooth surface without scratches, and by sharpening the tip it performs excellently for polishing fine areas and slits.

※ Please clamp it to the special tip holder (sold separately). Refer to p.5-11.

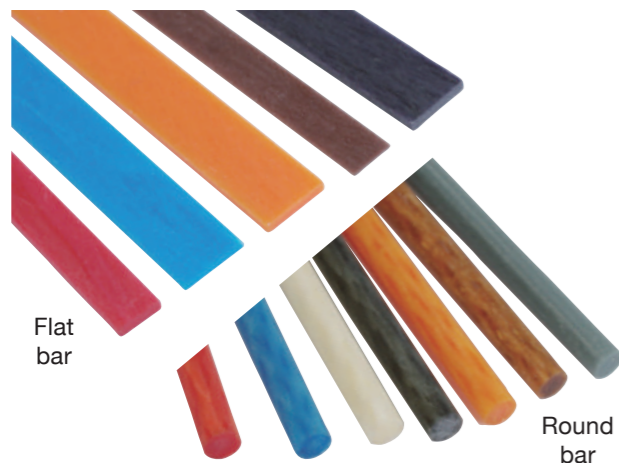

5 pcs./pack

Brass Lapping Tip

- This is a lapping tool for final finishing.
- Use with diamond compound or other abrasives.
- It is used to form according to the processing shape.

※ Please clamp it to the special tip holder (sold separately). Refer to p.5-11.

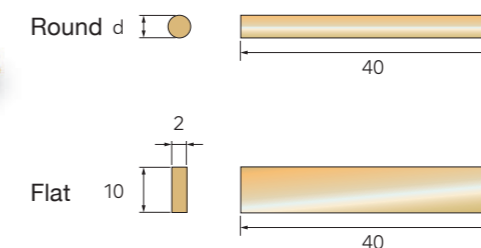

Diameter (d)	Code No.
ø2	60801
ø3	60802

60805

2 pcs./pack Ceramic Fiber Grindstone Tip



Thickness 1 mm		W=4 mm	W=6 mm
Grit Size	Color	Code No.	Code No.
# 120	Violet	60511	60516
# 220	Brown	60512	60517
# 400	Orange	60513	60518
# 800	Blue	60514	60519
# 1200	Red	60515	60520



Example of special tip holder installation

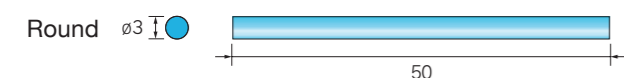

Diameter ø3		
Grit Size	Color	Code No.
# 220	Gray	60551
# 300	Mazenta	60552
# 400	Orange	60553
# 600	Black	60554
# 800	Blue	60555
# 1000	White	60556
# 1200	Red	60557



Example of special tip holder installation

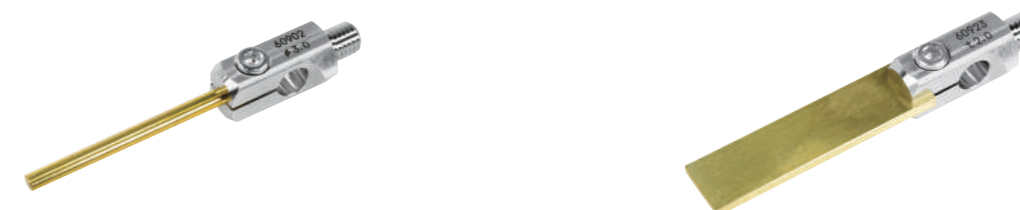

Example of special tip holder installation

These tools are specially designed for NAKANISHI's Ultrasonic Polishing System to achieve the ideal finish with powerful sonic vibrations.
A wide variety of tools are available to meet all kinds of processing situations.

<Precautions for use>

Select the CLAMP / UNCLAMP mode according to the tool you are using.



- ★ Suitable for finishing of high-hardness metals such as mold steel (removal of hardened electroplated layer, etc.) and heat treated metal. Also suitable for polishing of cemented carbide molds, aluminum molds, and copper alloy molds.
- ★ Ideal for grinding and polishing fine parts and rib slits of various molds for plastics, press, forging, headers, die-casting, etc.
- ★ It can be used for grinding and polishing ceramics, precision electronic parts, and precision mechanical parts.
- ★ It can handle a wide range of processing, from grinding of complex shapes and minute parts to mirror-polished finishes.

Special Tip Holder

<Features>

- This is a special holder for installing various types of tool tips. Please select according to the size and shape of the tip.
 - The power of the NAKANISHI "Sheenus ZERO" Ultrasonic Polishing System is efficiently transmitted to the tips.
- ※ Please be aware that NON-NAKANISHI genuine tools may not vibrate as required when mounted on the Sheenus ZERO due to the length, thickness, diameter, weight, specific gravity, and density of the tools.



2 pcs./pack Special Tip Holder



Attach round bar Ceramic Fiber tips.
Suitable for soft materials.

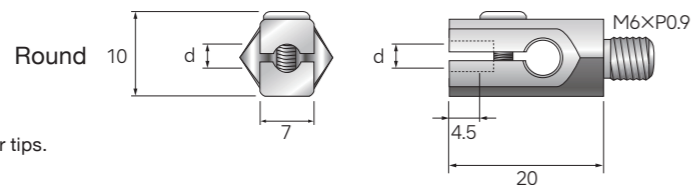

Diameter (d)	Code No.
ø2.0	60901
ø3.0	60902
ø3.3	60903
ø3.2	60904



Attach various round bar tips
(lapping brass tips, electroplated diamond files).
Suitable for hard materials.

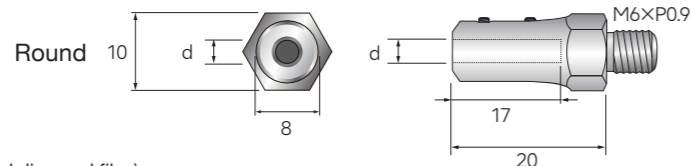

Diameter (d)	Code No.
ø2.0	60911
ø3.0	60912
ø3.2	60913



Attach a flat ceramic fiber tip.
Suitable for both hard and soft materials.

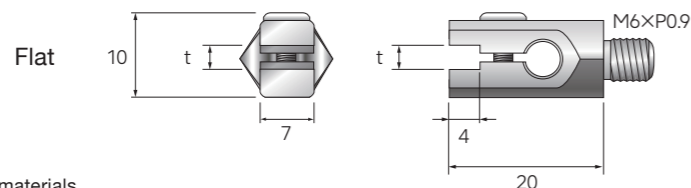

Thickness (t)	Code No.
0.8	60921
1.0	60922
2.0	60923
3.0	60924
3.3	60925

SHANK DIAMETER

Original tools that assist the LUSTER's powerful polishing ability to realize a speedy finish.
We have a wide variety of tools for a wide range of processes from filing to mirror finish.

- ▶ SHANK $\phi 3.0$
- ▶ SHANK $\phi 3.2$

Handy Type (reciprocating)
Tools for LUSTER



Grindstone Holder

1 pc./pack Maximum clampable thickness 4.5 x width 11 mm

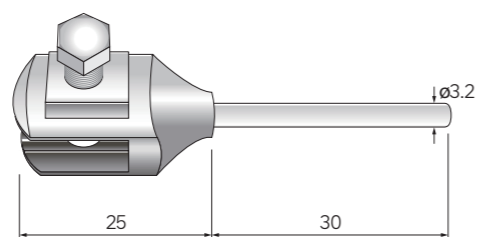
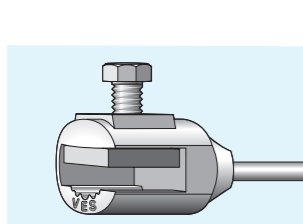

Code No.
62502

1 pc./pack Maximum clampable thickness 11 x width 13.5 mm

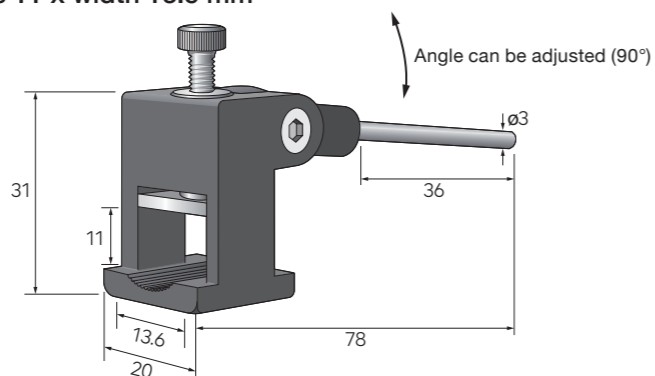

Code No.
62505

Ceramic Fiber Holder • Grindstone Holder

1 pc./pack Maximum clampable thickness 1 x width 4 mm

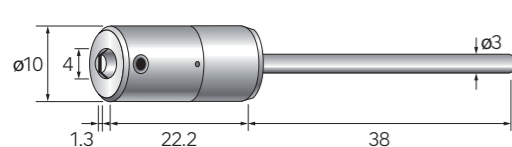

Code No.
62506

Maximum clampable thickness 1 x width 10 mm

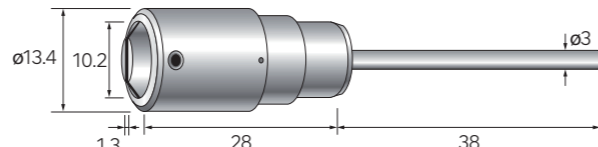

Code No.
62508

Maximum clampable thickness 1 x width 6 mm

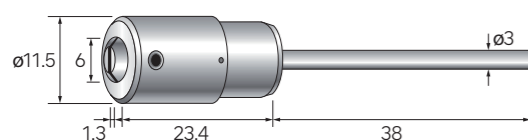

Code No.
62507

Grindstone Holder
Maximum clampable thickness 3 x width 6 mm

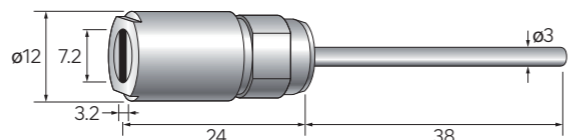

Code No.
62509

Flat Tip Holder

Attach the following Sandpaper and various polishing sheets.

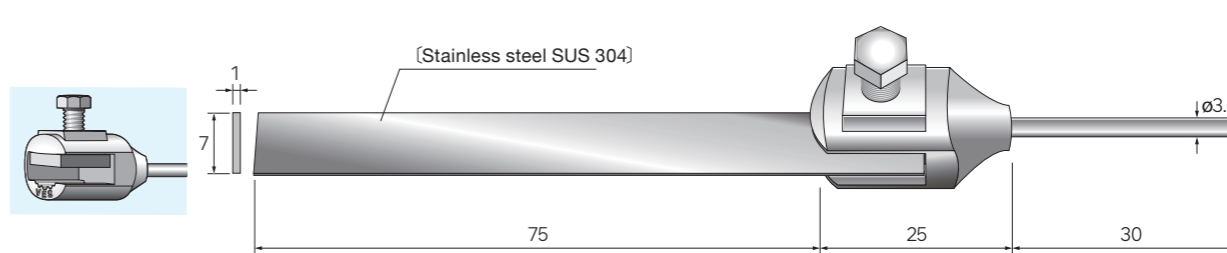

Code No.
62512

Square Pad Holder

The holder for polishing tips is ideal for polishing the bottom of a box shape.
The damper function allows the holder to continuously fit the work surface, and the angle can be freely adjusted to continuously capture the work surface for efficient polishing.

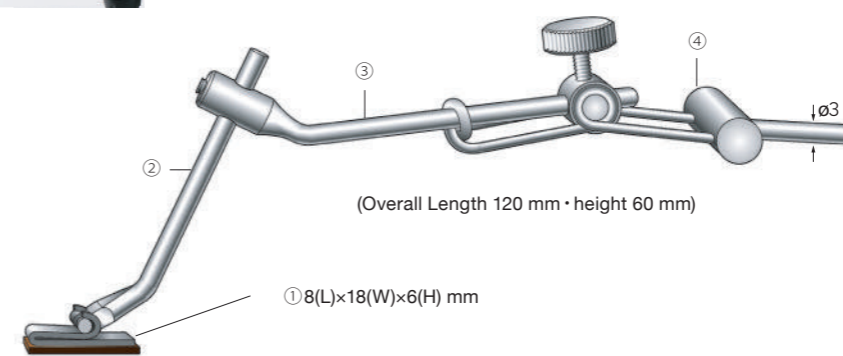

Code No.
62521

Parts	Code No.
① Rectangular Pad	62525
② Rod for Rectangular Pad	62526
③ Angle Rod	62527
④ Tool Holder with Spring	62751

※ Parts can be ordered separately.

Sandpaper

Please attach to a flat tip holder or rectangular pad holder.

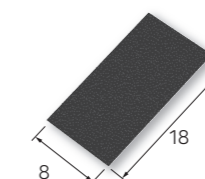

Grit Size	Code No.
# 120	62552
# 320	62555
# 600	62557
# 1000	62559

Adhesive Back

SHANK DIAMETER



Original tools that assist the LUSTER's powerful polishing ability to realize a speedy finish.
We have a wide variety of tools for a wide range of processes from filing to mirror finish.



- Suitable for finishing of high-hardness metals such as mold steel (removal of hardened electroplated layer, etc.) and heat treated metal. Also suitable for polishing of cemented carbide molds, aluminum molds, and copper alloy molds.
- Ideal for grinding and polishing fine parts and rib slits of various molds for plastics, press, forging, headers, die-casting, etc.
- It can be used for grinding and polishing ceramics, precision electronic parts, and precision mechanical parts.
- It can handle a wide range of processing, from grinding of complex shapes and minute parts to mirror-polished finishes.

Handy Type (reciprocating)
Tools for LUSTER

Electroplated Diamond File



- <Features>
- Diamond abrasive grains are electroplated to the file surface (electroplated coating).
 - The amount of protruding diamond grains is large, and the cutting performance is excellent.
 - We use carefully selected diamond abrasive grains and electroplate them particularly strongly for machine finishing, so they have excellent durability. It has excellent durability.
 - It is suitable for finishing of high-hardness metals such as mold steel, heat treated metal, cemented carbide, and ceramics, polishing and finishing of various molds, and deburring and correction of machine parts.

SHANK Ø3.0 1 pc./pack Electroplated Diamond File The illustrations on this page are 80% of the actual size.

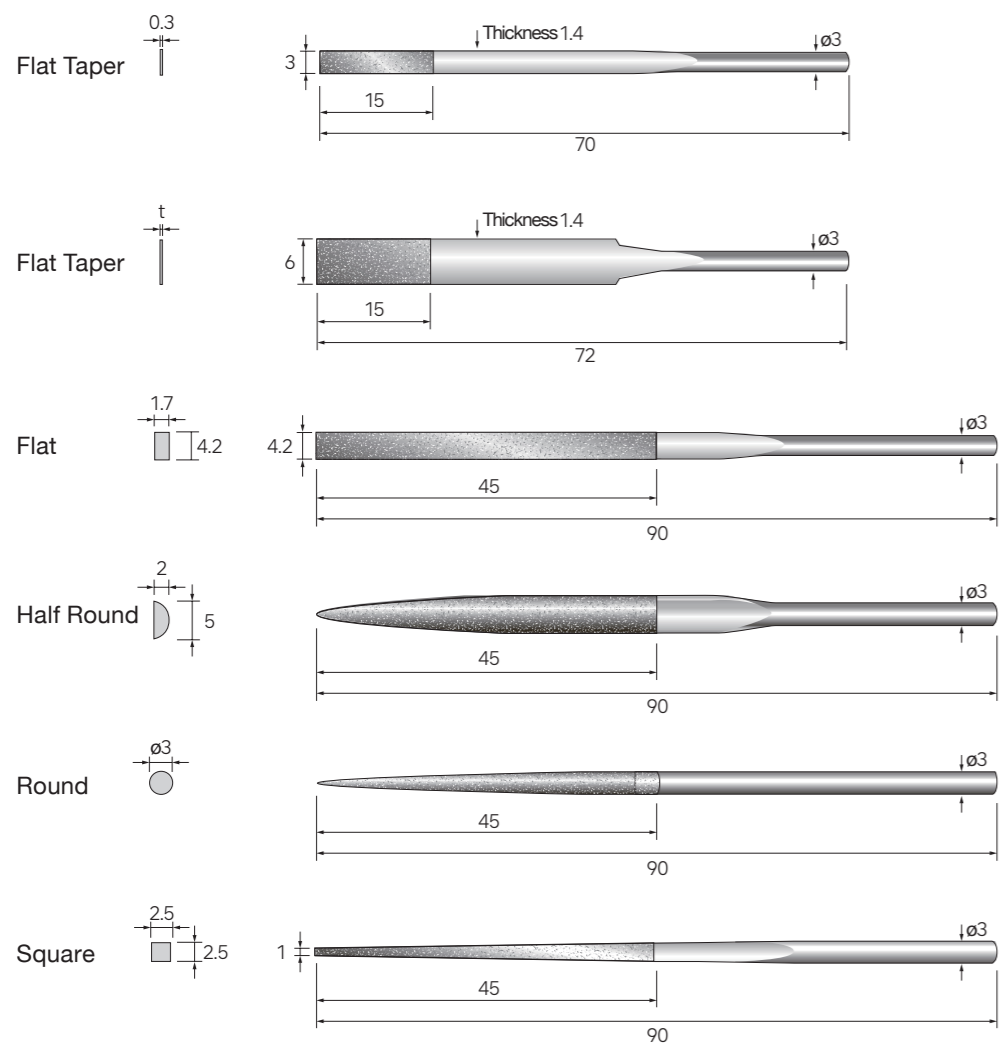

Grit Size	Code No.
#200	62301
#400	62302
#600	62303

Thickness (t)	Grit Size	Code No.
0.45	#200	62305
0.4	#400	62306
0.35	#600	62307

#150 62311

#150 62313

#150 62315

#150 62317

SHANK Ø3.0 1 pc./pack

Tool Holder with Spring



Common Tools for LUSTER and MINI-LUSTER

- <Features>
- This is a utility holder that allows files and various tools to fit the abrasive tip to the work surface by the spring damper function.
 - The damper function absorbs all the vertical movement (flapping and bouncing) of the abrasive tool during reciprocating motion, enabling ideal reciprocating motion.
 - This makes it possible to apply the grinding tool flatly to the work surface, resulting in highly efficient even and smooth surfaces.
 - Diamond files, various files, ceramic fiber grindstones (Ø3 mm), various lapping sticks, various holders, etc. can be installed and used.

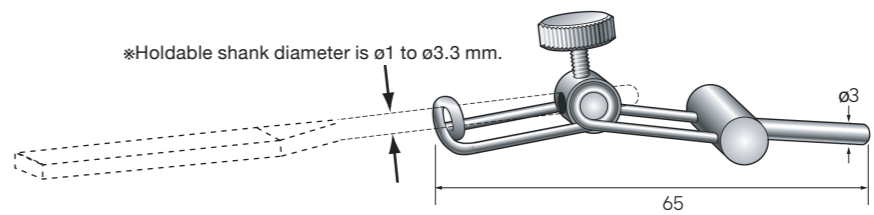

*Holdable shank diameter is Ø1 to Ø3.3 mm.

Code No.
62751

57301~

SHANK DIAMETER

SHANK $\phi 3.0$



Handy Type Reciprocating Grinder (Electric / Pneumatic) Exclusive Tools for "LUSTER"

Original tools that assist the LUSTER's powerful polishing ability to realize a speedy finish. We have a wide variety of tools for a wide range of processes from filing to mirror finish.



~57410

Handy Type (reciprocating)
Tools for LUSTER

Precision Finishing File (Flat, Round, Square, Triangular, Half-Round)

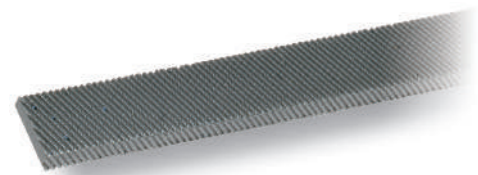

<Features>

- Ideal for precision finishing of general steel, brass, copper alloy, hard resin, etc.
- Carefully selected materials and advanced grading technology provide superior sharpness and durability.
- Speedy finishing is possible by using the LUSTER series (Electric / Pneumatic).

Coarse File for Plastic and Woodworking (Flat, Round, Square, Triangular, Half-Round)



<Features>

- Ideal for filing wood products, plywood, compressed materials, and plastics.
- It is characterized by its superior sharpness and durability due to its advanced grading technology.
- It can be used with the Luster Series (Electric / Pneumatic) for speedy finishing.

SHANK $\phi 3.0$ 3 pcs./pack

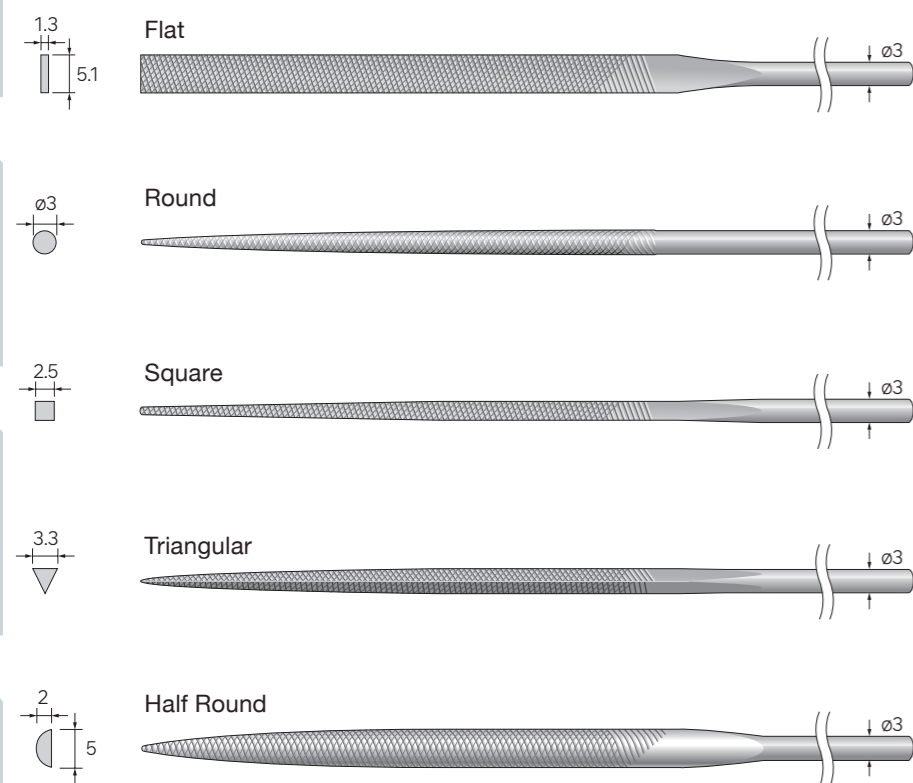

Overall length / 140 mm, Filing area / 70 mm

Medium-Grit		Fine-Grit	
Code No.		Code No.	
57301	Flat	57311	Flat
57302	Round	57312	Round
57303	Square	57313	Square
57304	Triangular	57314	Triangular
57305	Half Round	57315	Half Round

Set of 5 types

Precision Finishing File Medium-Grit Set
(No.57301~No.57305 Contains 1 pc. each)

No.57309

Precision Finishing File Fine-Grit Set
(No.57311~No.57315 Contains 1 pc. each)

No.57319

SHANK $\phi 3.0$ 3 pcs./pack

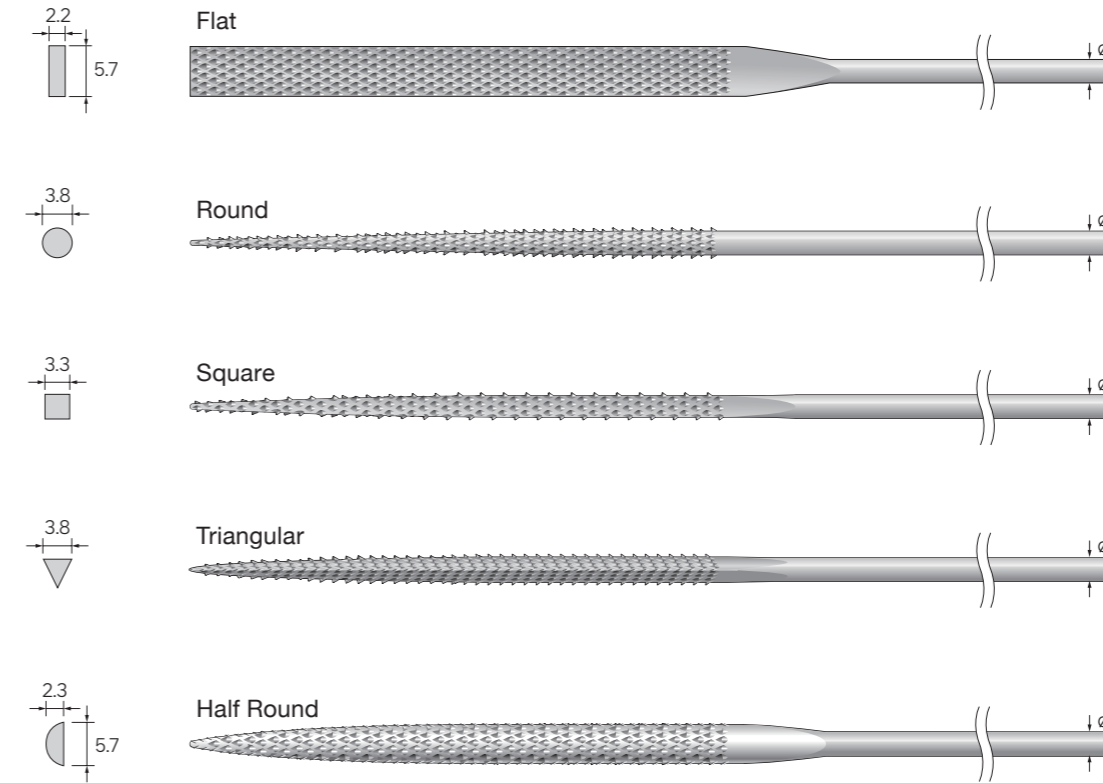

Overall length / 140 mm
Filing area / 69 mm

Code No.	
57401	Flat
57402	Round
57403	Square
57404	Triangular
57405	Half Round

Set of 5 types

Coarse File Plastic and Woodworking Set
(No.57401~No.57405 Contains 1 pc. each)

No.57410

▲ For safety reasons, always wear protective equipment such as safety glasses. Use at or below the indicated maximum allowable speed.

62506~

SHANK DIAMETER

- SHANK $\phi 3.0$
- SHANK $\phi 3.2$



Pencil Type Reciprocating Grinder (Electric / Pneumatic) Exclusive Tools for Polisher "MINI-LUSTER"

Designed to be easy to use, taking advantage of the features of the lightweight pencil type. The line-up of NAKANISHI's original tools is ideal for delicate and precise abrasive finishing.

(~62982)

Pencil Type (reciprocating) Tools for MINI-LUSTER

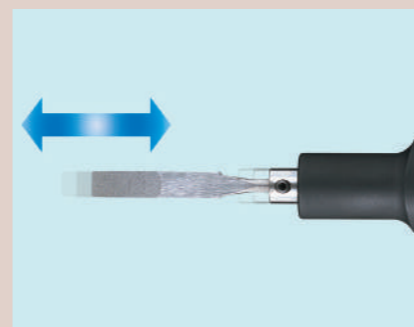

1 pc./pack

Ceramic Fiber Holder·Grindstone Holder

Maximum clampable thickness 1 x width 4 mm

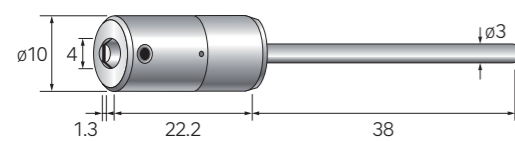

Code No.
62506

Maximum clampable thickness 1 x width 10 mm

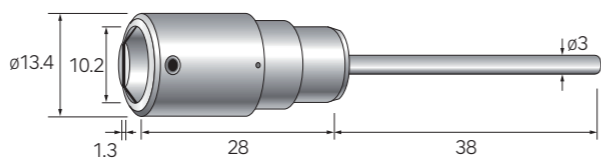

Code No.
62508

Maximum clampable thickness 1 x width 6 mm

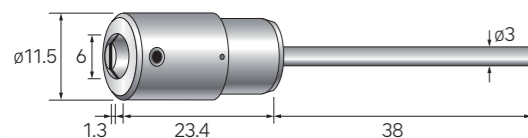

Code No.
62507

Grindstone Holder
Maximum clampable thickness 3 x width 6 mm

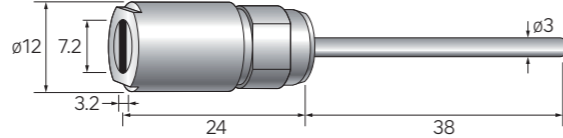

Code No.
62509

Maximum clampable thickness 1 x width 6 mm

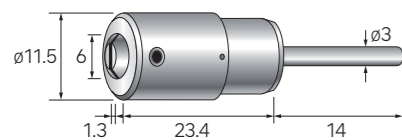

Code No.
62510

2 pcs./pack

Ceramic Fiber Grindstone

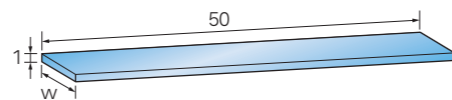
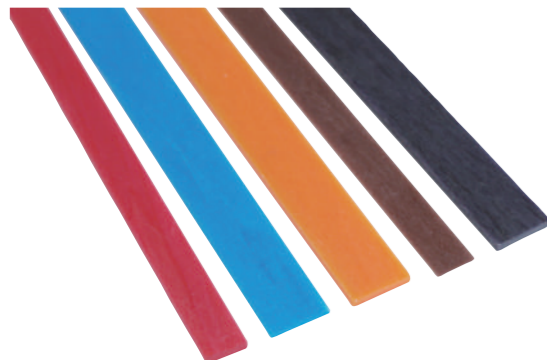

Grit Size	Color	W=4 mm	W=6 mm	W=10 mm
		Code No.	Code No.	Code No.
# 120	Violet	60511	60516	60521
# 220	Brown	60512	60517	60522
# 400	Orange	60513	60518	60523
# 800	Blue	60514	60519	60524
# 1200	Red	60515	60520	60525

1 pc./pack

Flat Tip Holder

- A variety of polishing tips can be attached to MINI-LUSTER for efficient finish polishing.
- In addition to the polishing tips listed below, a wide range of cut polishing sheets (diamond film, felt sheets, etc.) can be used.
- The compact holder can be mounted on the pencil type MINI-LUSTER in a well balanced manner and is easy to use.

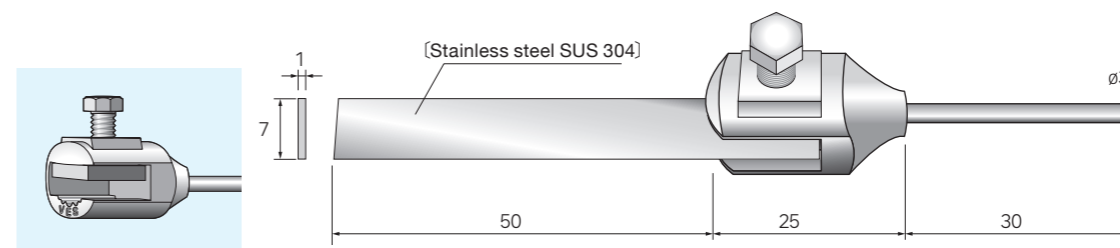

Code No.
62982

100 pcs./pack

Sandpaper

Please attach to a flat tip holder or rectangular pad holder.

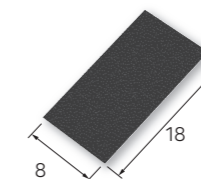

Adhesive Back	
Grit Size	Code No.
# 120	62552
# 320	62555
# 600	62557
# 1000	62559

1 pc./pack

Tool Holder with Spring

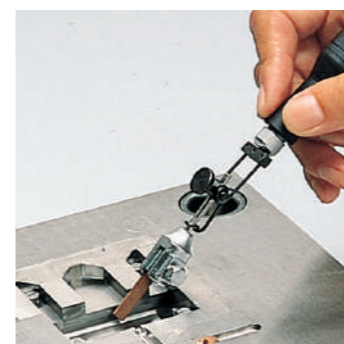

<Features>

- This is a utility holder that allows files and various tools to fit the abrasive tool to the work surface by the spring damper function.
- The damper function absorbs all the vertical movement (flapping and bouncing) of the abrasive tool during reciprocating motion, enabling ideal reciprocating motion.
- This makes it possible to apply the grinding tool flatly to the work surface, resulting in highly efficient, even and smooth surfaces.
- Diamond files, various files, ceramic fiber grindstone ($\phi 3$ mm), various lapping sticks, various holders, etc. can be installed and used.

*Holdable shank diameter is $\phi 1$ to $\phi 3.3$ mm.

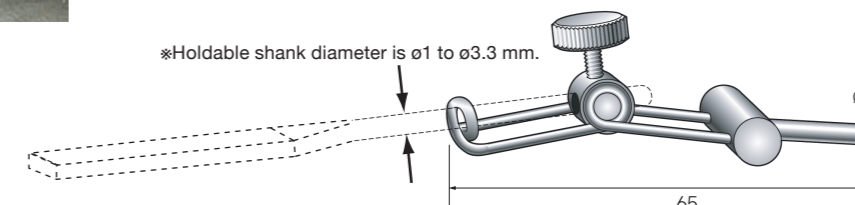

Code No.
62751

62801 ~

SHANK DIAMETER

SHANK $\phi 3.0$

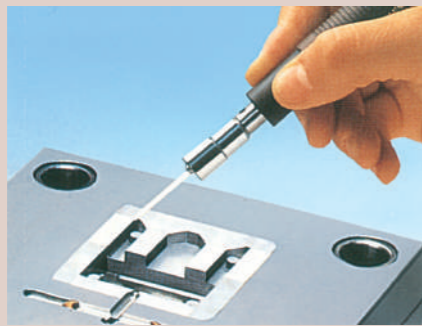

Pencil Type Reciprocating Grinder (Electric / Pneumatic) Exclusive Tools for Polisher "MINI-LUSTER"

Designed to be easy to use, taking advantage of the features of the lightweight pencil type. The line-up of NAKANISHI's original tools is ideal for delicate and precise abrasive finishing.

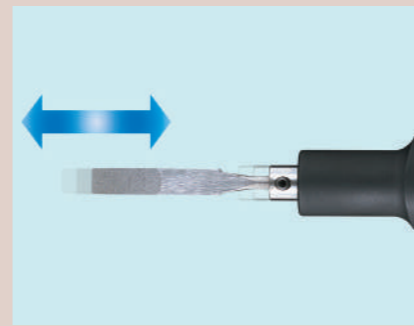

~62883

Pencil Type (reciprocating) Tools for MINI-LUSTER

Electroplated Diamond File



<Features>

- Diamond abrasive grains are electroplated to the file surface (electroplated coating).
- The amount of protruding diamond abrasive grains is large, and the cutting performance is excellent.
- We use carefully selected diamond abrasive grains and electroplate them particularly strongly for machine finishing, so they have excellent durability.
- It is suitable for finishing of high-hardness metals such as mold steel, heat treated metal, cemented carbide, and ceramics, polishing and finishing of various molds, and deburring and correction of machine parts.

SHANK $\phi 3.0$ 1 pc./pack Electroplated Diamond File

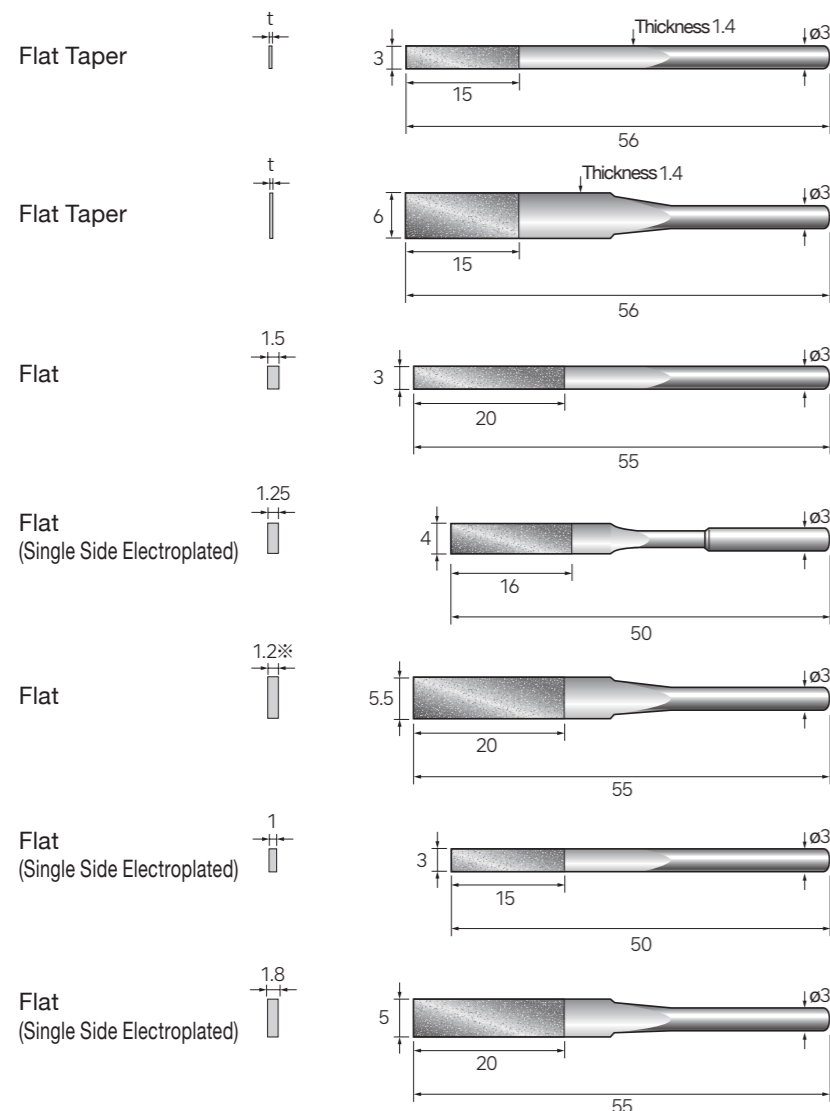

Thickness (t)	Grit Size	Code No.
0.5	#200	62801
0.4	#400	62802
0.35	#600	62803

0.5	#200	62805
0.4	#400	62806
0.35	#600	62807

#150	62811
#200	62812
#400	62813

#100	62814
------	-------

#150	62815
#200	62816
#400	62817

※ Thickness of 62815 is 1.4 mm.

#150	62821
#200	62822
#400	62823

#150	62825
#200	62826
#400	62827

SHANK $\phi 3.0$ 1 pc./pack Electroplated Diamond File

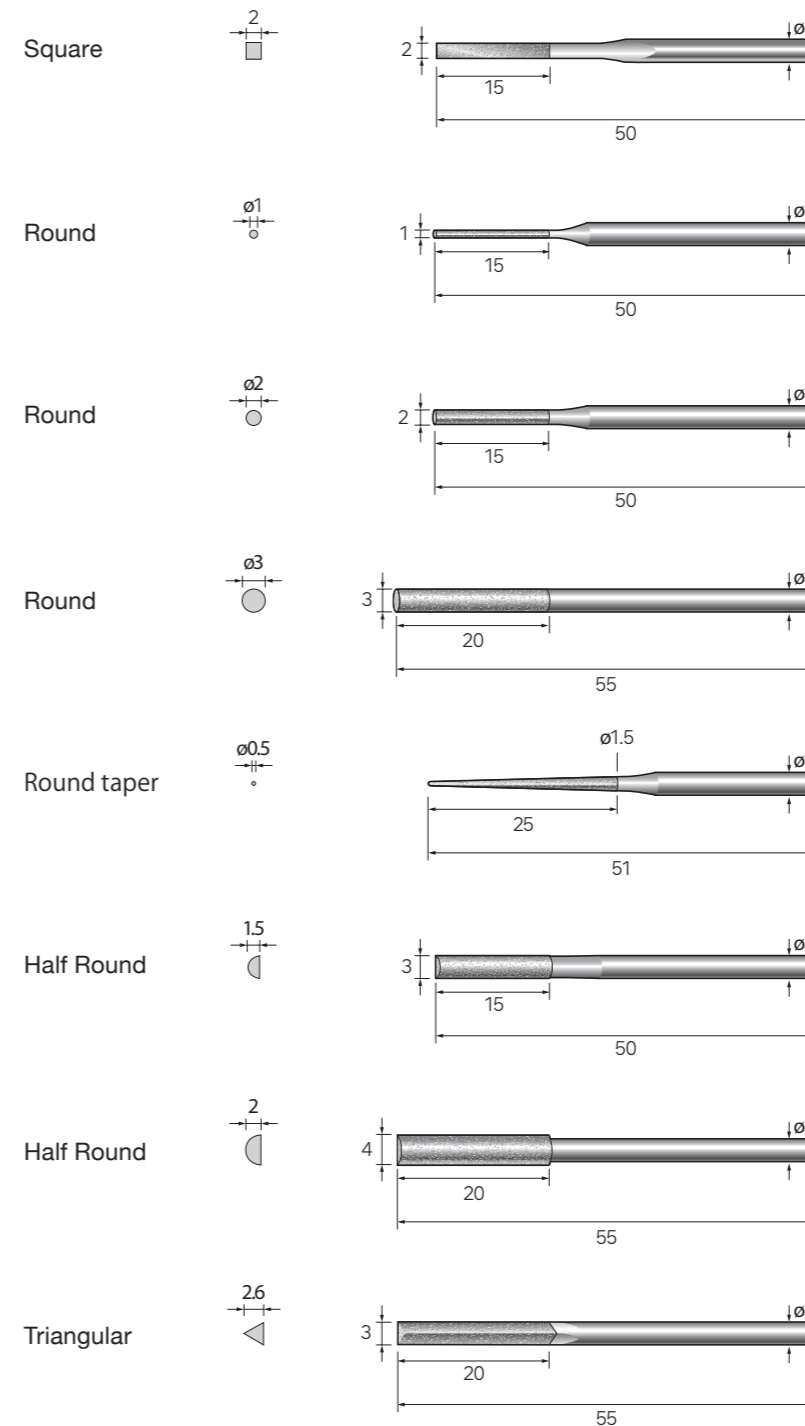

Grit Size	Code No.
#150	62831
#200	62832
#400	62833

#100	62840
#150	62841
#200	62842
#400	62843

#150	62845
#200	62846
#400	62847

#150	62851
#200	62852
#400	62853

#150	62855
#200	62856
#400	62857

#150	62865
#200	62866
#400	62867

#150	62871
#200	62872
#400	62873

#150	62881
#200	62882
#400	62883

▲ For safety reasons, always wear protective equipment such as safety glasses. Use at or below the indicated maximum allowable speed.

(51123~)

SHANK DIAMETER

SHANK ϕ 3.0

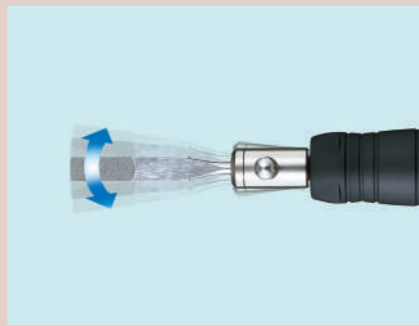

Pencil Type Swing Polisher (Electric / Pneumatic) Exclusive Tools for "SWING-LUSTER"

The left-right horizontal swinging file swings around narrow areas (ribs), corners, grooves (runners), etc., which cannot be polished with a reciprocating file, to achieve speedy polishing.



(~62827)

Pencil Type (swing) Tools for "SWING-LUSTER"

Electroplated Diamond File



<Features>

- Diamond abrasive grains are electroplated to the file surface (electroplated coating).
- The amount of protruding diamond abrasive grains is large, and the cutting performance is excellent.
- We use carefully selected diamond abrasive grains and electroplate them particularly strongly for machine finishing, so they have excellent durability.
- It is suitable for finishing of high-hardness metals such as mold steel, heat treated metal, cemented carbide, and ceramics, polishing and finishing of various molds, and deburring and correction of machine parts.

SHANK ϕ 3.0 1 pc./pack Electroplated Diamond File

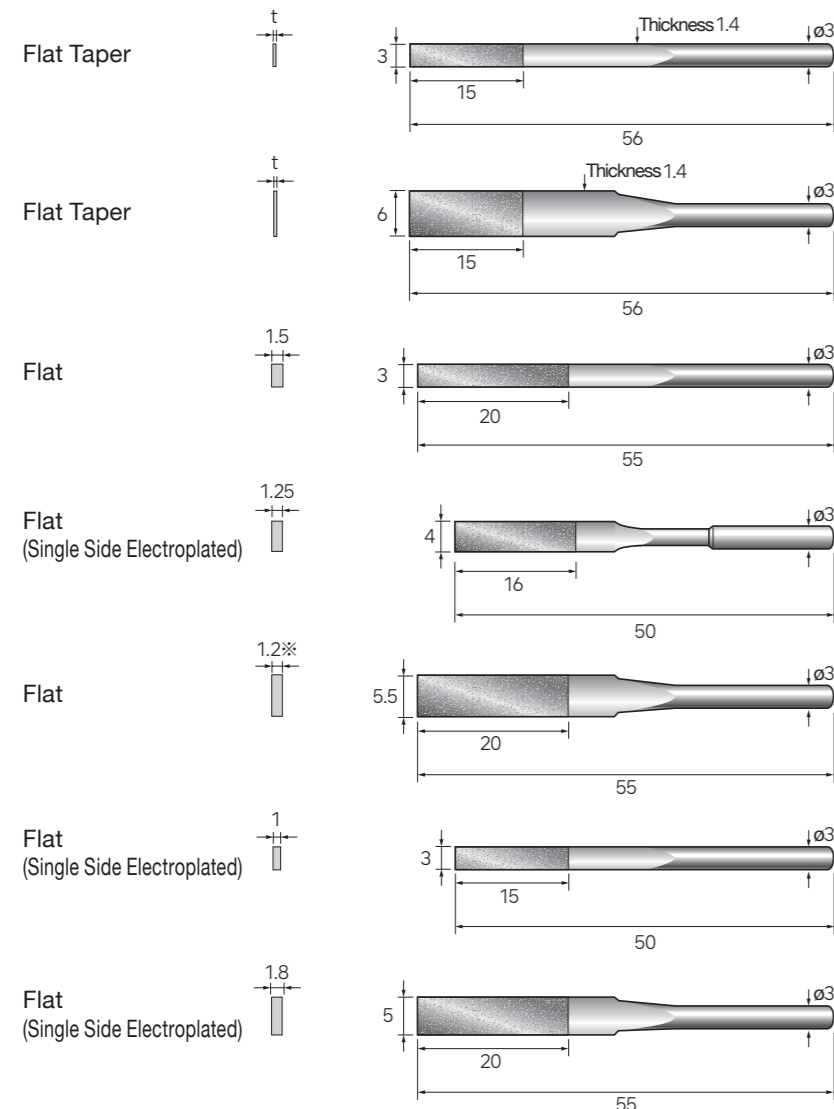

Thickness (t)	Grit Size	Code No.
0.5	#200	62801
0.4	#400	62802
0.35	#600	62803

0.5	#200	62805
0.4	#400	62806
0.35	#600	62807

#150	62811
#200	62812
#400	62813

#100	62814
------	-------

#150	62815
#200	62816
#400	62817

※ Thickness of 62815 is 1.4 mm.

#150	62821
#200	62822
#400	62823

#150	62825
#200	62826
#400	62827

2 pcs./pack

Flat type 50 mm

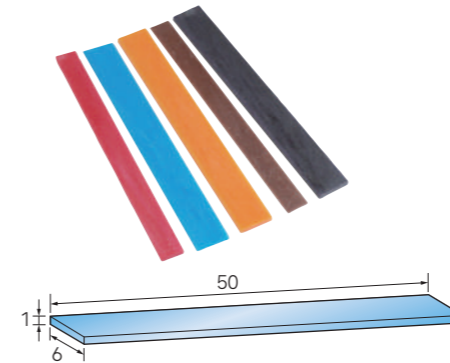

Ceramic Fiber Grindstone Tip

Thickness 1 mm x width 6 mm

Grit Size	Color	Code No.
# 120	Violet	60516
# 220	Brown	60517
# 400	Orange	60518
# 800	Blue	60519
# 1200	Red	60520

Round bar type 50 mm

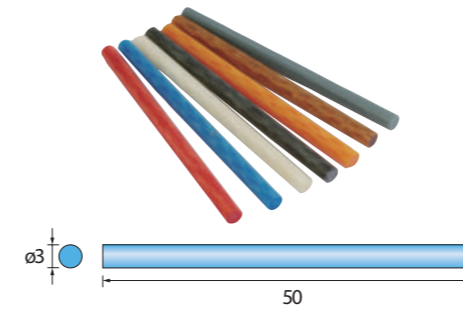

ϕ 3 mm

Grit Size	Color	Code No.
# 220	Gray	60551
# 300	Mazenta	60552
# 400	Orange	60553
# 600	Black	60554
# 800	Blue	60555
# 1000	White	60556
# 1200	Red	60557

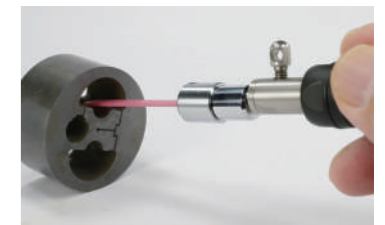

With 6 mm wide flat tip



With ϕ 3 mm round bar



With sharpened tip of round bar

SHANK ϕ 3.0 1 pc./pack

Ceramic Fiber Holder

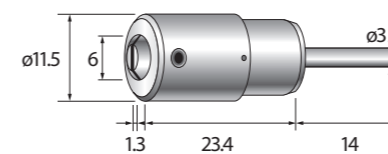

Max. clampable thickness 1 mm x width 6 mm

Code No.	62510
----------	-------

SHANK ϕ 3.0 1 pc./pack

Ceramic Fiber Brush

The grindstone is now in brush form.



Brush diameter	Brush length	Overall length	Finishing (Pink)	Middle Finishing (Red)	Rough Finishing (Blue)
ϕ 2	15	52*	51123	51133	51141
ϕ 2.5	15	52*	51124	51134	51142

※Blue's overall length is 50 mm.

▲ For safety reasons, always wear protective equipment such as safety glasses. Use at or below the indicated maximum allowable speed.

64101~

Angle Type Grinder (Electric / Pneumatic) Exclusive Tools for "Angle Type"

~64274

SHANK DIAMETER

NAKANISHI Angle Grinders are available with a wide range of tools for a variety of machining operations, from cutting to grinding, polishing and lapping.

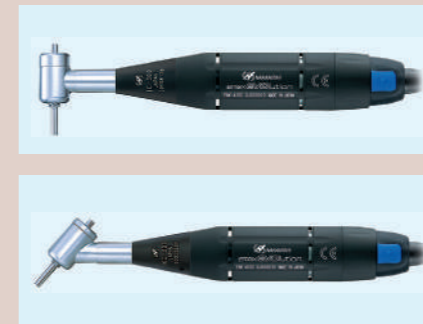
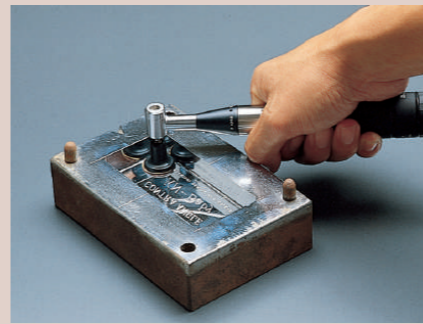

Angle Type



Special Rubber Pads for Abrasive and Felt Discs

- It is used by attaching various types of polishing discs.
- The elasticity of the rubber makes it ideal for finishing flat and curved surfaces.

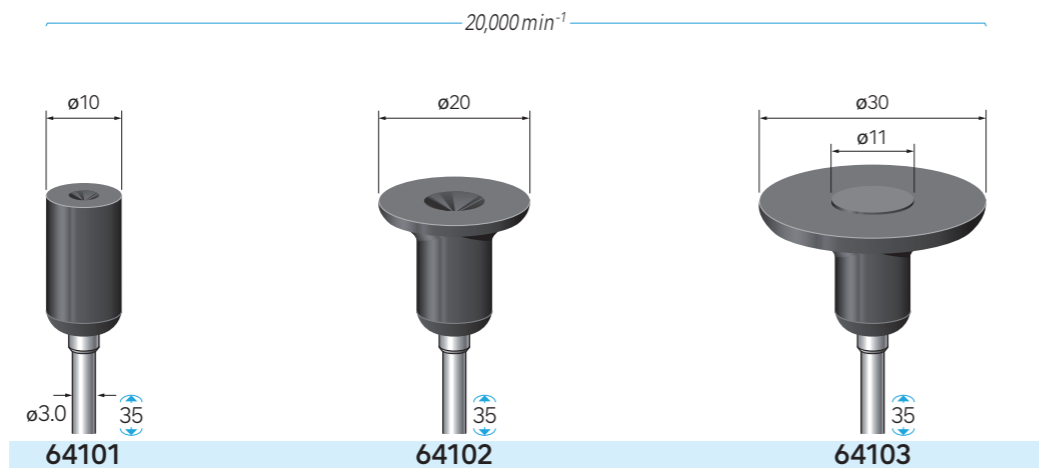

Sandpaper Discs (paper base type)

- Suitable for metal, woodwork, painted surfaces and putty polishing
- Use in dry conditions



		Adhesive Back		
Grit Size		Ø11	Ø21	Ø31
# 80	64201	64211	64221	
# 120	64202	64212	64222	
# 180	64203	64213	64223	
# 240	64204	64214	64224	
# 320	64205	64215	64225	
# 400	64206	64216	64226	
# 600	64207	64217	64227	



Sandpaper Discs (fabric base type)

- Ideal for metalworking
- Excellent durability
- Use in dry conditions

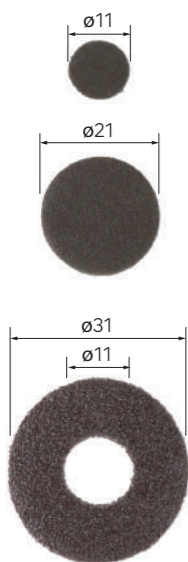

		Adhesive Back		
Grit Size		Ø11	Ø21	Ø31
# 60	64111	64121	64141	
# 80	64112	64122	64142	
# 120	64113	64123	64143	
# 180	64114	64124	64144	
# 240	64115	64125	64145	
# 320	64116	64126	64146	
# 400	64117	64127	64147	
# 600	64118	64128	64148	



Zirconia Disks

- These discs are specially coated with zirconia abrasive grains to provide excellent cutting performance and durability for difficult-to-machine materials.
- Ideal for machining metals such as aluminium, stainless steel, copper alloys and brass, which are prone to clogging.



		Adhesive Back		
Grit Size		Ø11	Ø21	Ø31
# 60	64251	64261	64271	
# 80	64252	64262	64272	
# 120	64253	64263	64273	
# 150	64254	64264	64274	

64331 ~

Angle Type Grinder (Electric / Pneumatic) Exclusive Tools for "Angle Type"

SHANK DIAMETER

NAKANISHI Angle Grinders are available with a wide range of tools for a variety of machining operations, from cutting to grinding, polishing and lapping.



~64432

Angle Type

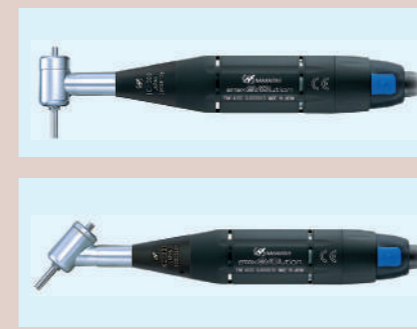

20 pcs./pack

Felt Discs

- Ideal for use in combination with various abrasives (diamond compound, polishing compound) for finish polishing.
- Made from 100% high quality sheep's wool, with moderate elasticity and sufficient durability for repeated polishing operations.
- High wool density ensures that abrasives and abrasive grains are held in place and the surface is polished.

Adhesive Back

Product name	ø11	ø21	ø31
Felt Discs (1 mm thick) Soft	64331	64332	64333
Felt Discs (2 mm thick) Soft	64335	64336	64337

* Sheeted types are available.



SHANK Ø3.0 5 pcs./pack

Rubber grinding wheel disc with shaft (Integrated rubber pad)

- The newly developed special rubber holds the abrasive grains with the right amount of hardness and boasts exceptional polishing ability.
- The grinding wheel part is integrally moulded into the rubber pad for superior workability.
- Highly efficient finishing of flat and curved surfaces with a soft touch.

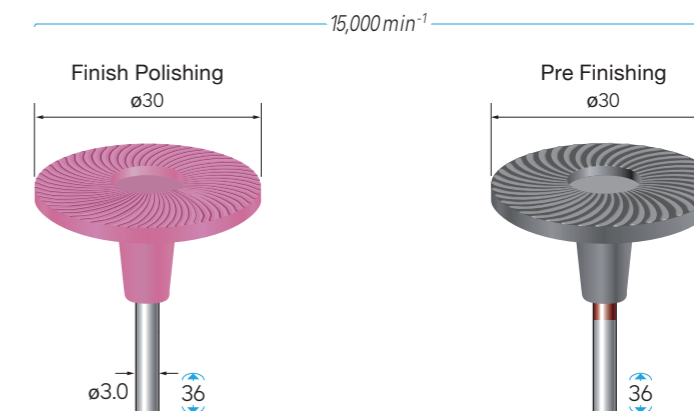

Finish Polishing

Grit Size	Color	WA abrasive grains	GC abrasive grains
# 80	Pink	64411	—
# 80	Purple	—	64421
# 120	Blue	64412	64422
# 180	Yellow	64413	—
# 180	Green	—	64423
# 220	Green	64414	64424
# 320	Purple	64415	64425
# 500	Orange	64416	—
# 500	Brown	—	64426

Pre Finishing (Excellent grindability)

Grit Size	Color	WA abrasive grains
# 80	Black(Red line)	64431
# 120	Black(Blue line)	64432

Angle Type Grinder (Electric / Pneumatic) Exclusive Tools for "Angle Type"

NAKANISHI Angle Grinders are available with a wide range of tools for a variety of machining operations, from cutting to grinding, polishing and lapping.

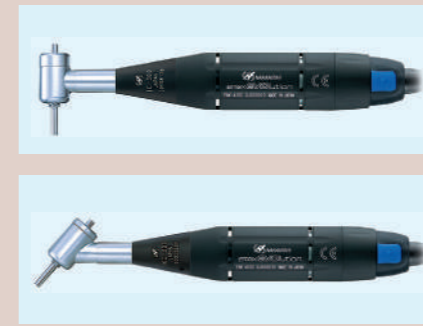

Angle Type

1 pc./pack

Diamond Discs (Full electroplated surface)

The base material is an ultra-thin copper alloy, with diamond abrasive grains electroplated over the entire surface.

- The metal base material has good electrodeposition plating conditions and adheres diamond abrasive grains uniformly and most firmly.
- Very good sharpness and durability.

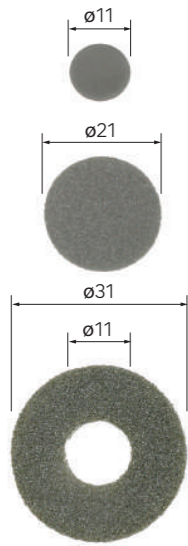

Adhesive Back

Grit Size	ø11	ø21	ø31
# 100	64451	64461	64471
# 140	64452	64462	64472
# 200	64453	64463	64473
# 280	64454	64464	64474
# 400	64455	64465	64475
# 600	64456	64466	64476
# 800	64457	64467	64477
# 1000	64458	64468	64478

* Sheeted types are available.

3 pcs./pack

Resin Bond Diamond Discs

Diamond abrasive grains are mixed with resin bond and coated on the resin base material.

- The resin component provides a uniform and stable finished surface and a soft grinding feel.
- ※ This resin bond type requires dressing only for the first use.
The cutting edges of the abrasive grains are exposed by lightly shaving the surface with a grindstone or diamond file.



Adhesive Back

Grit Size	ø11	ø21	ø31
# 80	64531	64541	64551
# 120	64532	64542	64552
# 180	64533	64543	64553
# 240	64534	64544	64554
# 400	64535	64545	64555
# 800	64537	64547	64557
# 1000	64538	64548	64558
# 2000	64539	64549	64559

1 pc./pack

Diamond Discs (Dot electroplated type for wet applications)

Nickel alloy pellets with diamond electrodeposition are strongly bonded to the Resin base material.

- The dot pattern is characterized by its strong grinding performance.
- Dot spaces allow chips and grinding fluid to flow smoothly.
- The resin base material is made of a fiber-filled resin that excels in flexibility and toughness.

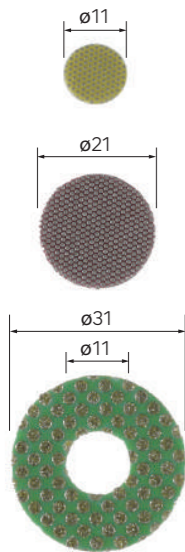

Adhesive Back

Grit Size	Color	ø11	ø21	ø31
# 60	Green	64501	64511	64521
# 120	Black	64502	64512	64522
# 200	Red	64503	64513	64523
# 400	Yellow	64504	64514	64524
# 800	Gray	64505	64515	64525

* Sheeted types are available.

11131~

SHANK DIAMETER

SHANK $\phi 1.6$

MINI Angle Type



Angle Type Grinder (Electric / Pneumatic) Exclusive Tools for "MINI ANGLE Type"

NAKANISHI Angle Grinders are available with a wide range of tools for a variety of machining operations, from cutting to grinding, polishing and lapping.



Compact Handy Belt Sander (Electric / Pneumatic) Exclusive Tools for "FINE BELT SANDER"

Powerful belt grinding power.
High-quality special belt for processing as desired.
The precise, lightweight, and compact NAKANISHI Belt Sander functions at 100%.

~65027

Fine Belt Sander

Diamond Burs for Deep Hole Chamfering

SHANK $\phi 1.6$ 1 pc./pack Diamond Burs for Deep Hole Chamfering

- Ideal for machining hardened steel, cemented carbide, ceramics, etc.

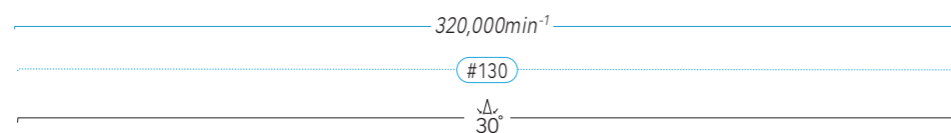
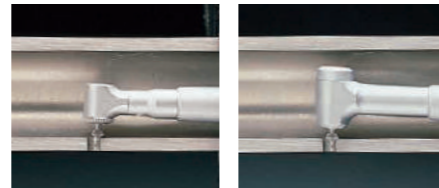

Diamond abrasive grains

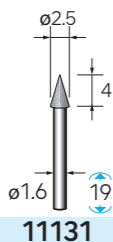

11131

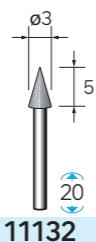

11132

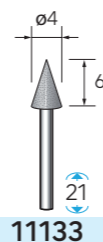

11133

SHANK $\phi 1.6$ 1 pc./pack Diamond Burs for Deep Hole Chamfering

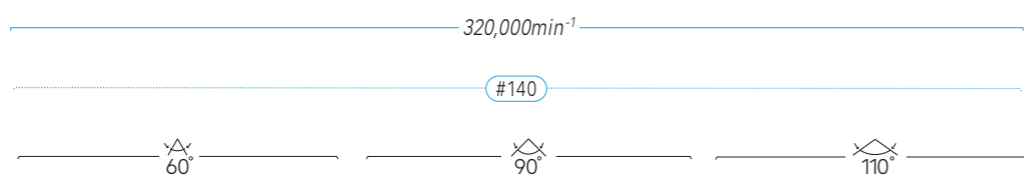

Diamond abrasive grains

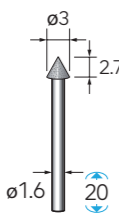

11151

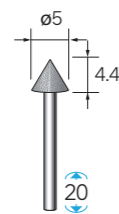

11152

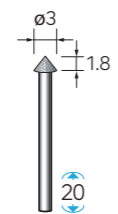

11153

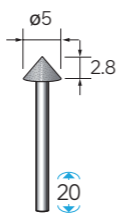

11154

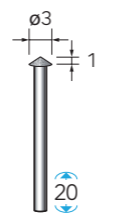

11155

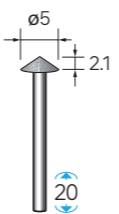

11156

Tools of $\phi 1.6$ mm shank

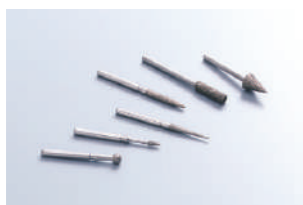

Diamond Burs



Carbide Burs

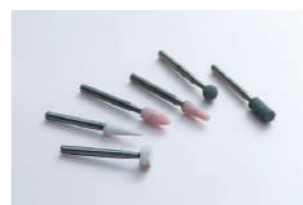

Mounted Abrasive Points



Abrasive Rubber Points

Sand Belt

30 pcs./pack Circumference 300 mm



- High quality Sanding Belt with excellent grindability and durability.
- Highly efficient grinding with a soft touch and less grain dropout even at high rim speeds.

● Assorted set for Pre Finishing (● mark)
4 Grit sizes (10 pcs. each)
Total 40 pcs. per pack

No.64931

● Assorted set for Finishing (● mark)
4 Grit sizes (10 pcs. each)
Total 40 pcs. per pack

No.64932

For metal processing

	W=4 mm	W=6 mm	W=8 mm
Grit Size	Code No.	Code No.	Code No.
# 80	64901	64911	64921
# 120	64902	64912	64922
# 180	64903	64913	64923
# 240	64904	64914	64924
# 320	64905	64915	64925
# 400	64906	64916	64926
# 600	—	—	64927
# 800	—	—	64928

Zirconia Belt

30 pcs./pack Circumference 300 mm



- Ideal for machining metals such as aluminium, stainless steel, copper alloys and brass, which are prone to clogging.
- These belts are specially coated with zirconia abrasive grains to provide excellent durability for difficult-to-grind materials.

● Assorted set 8 mm width
All 3 Grit sizes (10 pcs. each)
Total 30 pcs.

No.64975

Grit Size	Code No.
# 80	64971
# 100	64972
# 120	64973

Diamond Belt

3 pcs./pack Hard type (circumference 300 mm)



- Excellent cutting performance enables high productivity and cost reduction.
- Excellent wear resistance and durability, and stable finish machined surfaces can be maintained.
- Suitable for highly efficient machining of carbide, hardened steel, mold steel, special steel, ceramics, FRP, carbon fiber, glass, stone, and difficult-to-machine materials.

● Assorted set 8 mm width
All 5 Grit sizes (1 pc. each)
Total 5 pcs.

No.65019

Hard type

Grit Size	Code No.	Grit Size	Code No.
# 80	65011	# 320	65015
# 120	65012	# 600	65017
# 240	65014		

3 pcs./pack Soft type (circumference 300 mm)



● Assorted set 8 mm width
All 8 Grit sizes (1 pc. each)
Total 8 pcs.

No.65030

Soft type

Grit Size	Code No.	Grit Size	Code No.
# 120	65021	# 400	65028
# 180	65022	# 600	65025
# 240	65023	# 800	65026
# 320	65024	# 1000	65027

NAKANISHI Solutions

- CNC Lathes, Special Purpose Machines and Robot Automation Solution
- Cutting and Drilling PC Boards Solution
- Air Bearing Spindle Solution

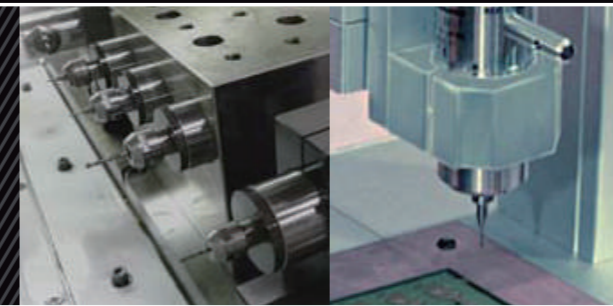

- Machining Center Solution

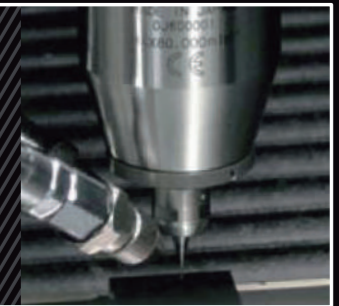

Electric System

Electric Motor Spindles



- A great variety of spindles.
- MAX rotation 80,000 min⁻¹ (E3000, iSpeed3)
- MAX output power 1,200 W (E4000)
- Many parameters to set the delicate cutting conditions.

iSpeed3 Series

1,000~80,000 min⁻¹
Max.150 W
《ø22·20·19.05 mm》



E4000 Series

1,000~40,000 min⁻¹
Max.1,200 W
《ø40 mm》



E3000 Series

1,000~80,000 min⁻¹
Max.350 W
《ø50·48·40·30·
26.8·25·22·20 mm》



E2000 Series

1,000~50,000 min⁻¹
Max.200 W
《ø22.8 mm》



HES Series

1,000~80,000 min⁻¹
< With small drilling and milling >



Air System

Air Motor Spindles



- A great variety of spindles
- MAX rotation 30,000 min⁻¹
- MAX output power 130 W.
- Excellent cost performance and easy setup.

Air-Speed One Piece Type

1,500~30,000 min⁻¹
《ø25·23·20·19.05 mm》



Air-Speed Separate Type

1,000~30,000 min⁻¹
《ø30·25·22.8 mm》



Air Turbine Spindles



Xpeed Series

Max.160,000 min⁻¹
《ø65·40 mm》



ABT Series

Max.160,000 min⁻¹
《ø40 mm》



HTS Series Bearing Type

150,000 min⁻¹
< With small and milling >



PLANET Series Bearing Type

65,000 min⁻¹
< Jig Grinder >

