

CARBIDE CUTTERS

SHANK $\phi 3.0$
12 pcs./pack **Single Cut Assorted Set**



28111 Titanium Coating	
Set (12 pieces) (Each code No. one piece-pack)	
21201	21245
21205	21261
21212	21262
21213	21265
21241	21272
21242	21275

SHANK $\phi 2.34$
12 pcs./pack **Single Cut Assorted Set**



28121	
Set (12 pieces) (Each code No. one piece-pack)	
23014	23132
23017	23133
23019	23161
23022	23162
23024	23163
23131	23166

SHANK $\phi 3.0$
12 pcs./pack **Single Cut Assorted Set**

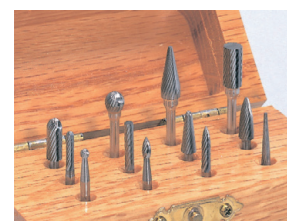

28141	
Set (12 pieces) (Each code No. one piece-pack)	
24016	24301
24019	24303
24041	24305
24044	24402
24161	24452
24164	24454

SHANK $\phi 6.0$
8 pcs./pack **Single Cut Assorted Set**



28171	
Set (8 pieces) (Each code No. one piece-pack)	
26011	26111
26031	26131
26071	26151
26091	26171

SHANK $\phi 6.0$
8 pcs./pack **Double Cut Assorted Set**



28181	
Set (8 pieces) (Each code No. one piece-pack)	
26021	26121
26041	26141
26081	26161
26101	26181

SHANK $\phi 3.0$
12 pcs./pack **Alloy Cut Assorted Set**

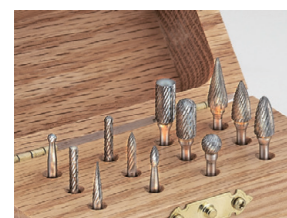

24601	
Set (12 pieces) (Each code No. one piece-pack)	
24611	24646
24612	24651
24622	24653
24623	24654
24631	24661
24632	24663

SHANK $\phi 6.0$
8 pcs./pack **Double Cut Assorted Set**

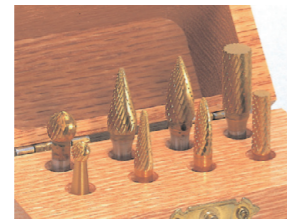

28115 Titanium Coating	
Set (8 pieces) (Each code No. one piece-pack)	
21511	21535
21512	21536
21515	21541
21516	21546

12 pcs./pack **Double Cut Assorted Set**



28125	
Set (12 pieces) (Each code No. one piece-pack)	
23403	23415
23405	23416
23407	23504
23410	23507
23412	23553
23413	23573

12 pcs./pack **Double Cut Assorted Set**



28145	
Set (12 pieces) (Each code No. one piece-pack)	
24073	24362
24076	24364
24093	24366
24096	24504
24214	24532
24217	24534

8 pcs./pack **Single Cut Assorted Set**



28175	
Set (8 pieces) (Each code No. one piece-pack)	
26013	26113
26033	26133
26073	26153
26092	26172

8 pcs./pack **Double Cut Assorted Set**



28185	
Set (8 pieces) (Each code No. one piece-pack)	
26023	26123
26043	26143
26083	26163
26102	26182

1 pc./pack **Wood Case**



SPECIALTY TOOLS



High Speed Steel(H.S.S.)Cutters.
For cutting of general steels,
light metals, non-metals, plastics,
resins, etc.

SHANK $\phi 3.0$
1 pc./pack

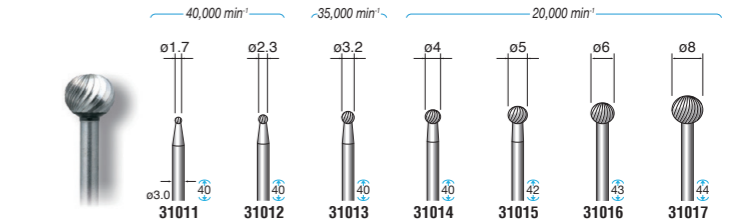

SHANK $\phi 3.0$
1 pc./pack

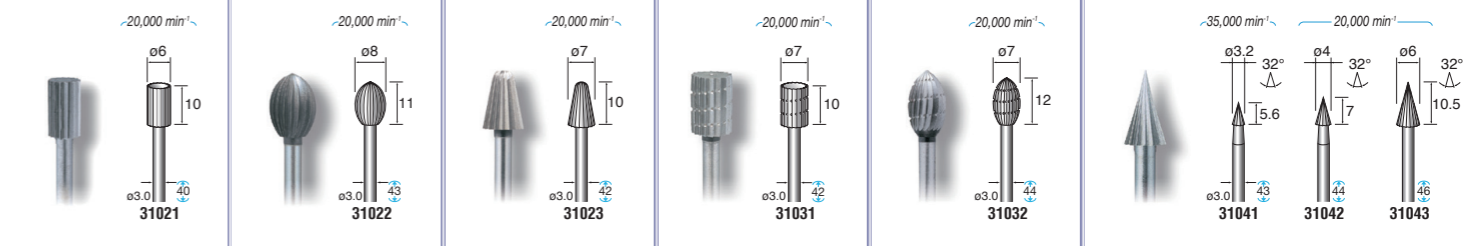

SHANK $\phi 3.0$
1 pc./pack

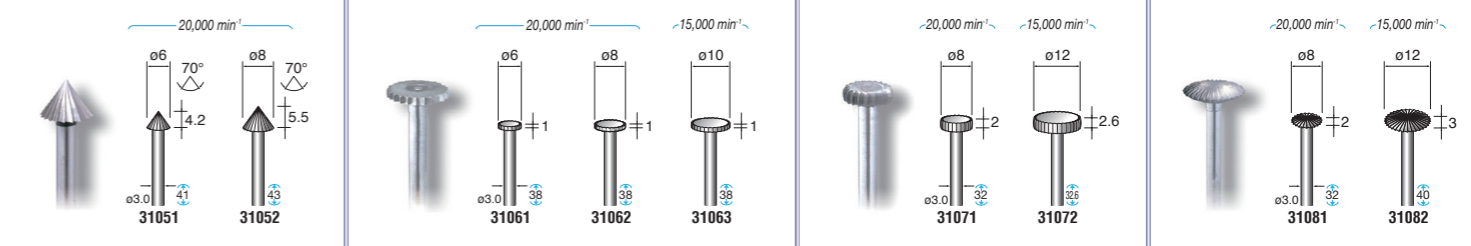

Tungsten Vanadium Steel Cutters.
For fine finishing of soft materials,
resins, bronze, acrylics, etc.

SHANK $\phi 2.34$
12 pcs./pack

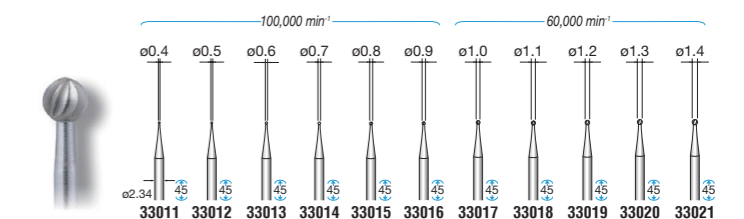

SHANK $\phi 2.34$
12 pcs./pack

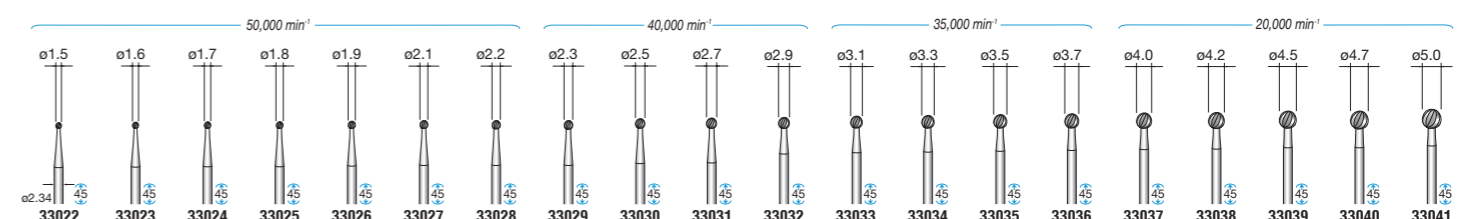

SHANK $\phi 2.34$
12 pcs./pack

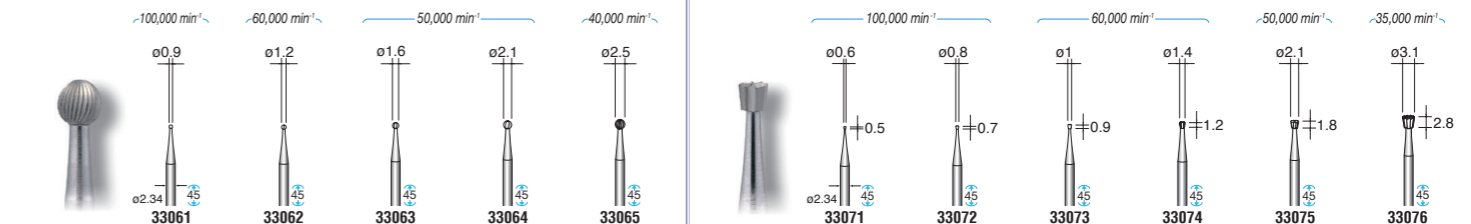

SPECIALTY TOOLS

SHANK $\phi 2.34$
12 pcs./pack

100,000 min⁻¹ 60,000 min⁻¹ 35,000 min⁻¹ 20,000 min⁻¹

33091 33092 33094 33095 33096

12 pcs./pack Tapered Type

100,000 min⁻¹ 60,000 min⁻¹ 50,000 min⁻¹ 40,000 min⁻¹

33111 33112 33113 33114 33115 33116 33117 33118 33119

SHANK $\phi 2.34$
12 pcs./pack Straight Type

60,000 min⁻¹ 50,000 min⁻¹ 40,000 min⁻¹

33121 33122 33123 33124 33125

12 pcs./pack 6 pcs./pack

100,000 min⁻¹ 50,000 min⁻¹ 35,000 min⁻¹ 20,000 min⁻¹

33151 33152 33153 33163

SHANK $\phi 2.34$
12 pcs./pack

60,000 min⁻¹ 50,000 min⁻¹ 30,000 min⁻¹ 35,000 min⁻¹ 20,000 min⁻¹

33171 33172 33175 33176 33173 33177 33174

12 pcs./pack 1 pc./pack

60,000 min⁻¹ 50,000 min⁻¹ 35,000 min⁻¹ 20,000 min⁻¹

33181 33182 33183 33184 33185 33191

SHANK $\phi 2.34$
12 pcs./pack

100,000 min⁻¹ 35,000 min⁻¹ 40,000 min⁻¹ 20,000 min⁻¹ 15,000 min⁻¹

33201 33202 33211 33212 33213 33214

10 pcs./pack Saw Blade

13,000 min⁻¹ 11,000 min⁻¹ 9,000 min⁻¹ 7,000 min⁻¹ 5,000 min⁻¹

33311 33312 33313 33314 33315

*Use with corresponding mandrels P.29(37011, 37012, 37015, 37051). *Mandrel is purchased separately.

SHANK $\phi 2.34$
6 pcs./pack

20,000 min⁻¹ 20,000 min⁻¹ 14,000 min⁻¹ 20,000 min⁻¹

33341 33342 33343 33345 33346 33361 33365 33366

SHANK $\phi 2.34$
6 pcs./pack

20,000 min⁻¹ 20,000 min⁻¹

33371 33372 33373 33375 33376 33391

SHANK $\phi 3.0$
6 pcs./pack

30,000 min⁻¹

33401 33402 33403

*Cutting for plastic and acryl.

SPECIALTY TOOLS

Wood and Plastic working rotary rasps and files. Three types for rough cutting, pre-finishing and finishing.

SHANK $\phi 3.0$
10 pcs./pack Single Cut

Better surface finish

10,000 min⁻¹

33481 33482 33483 33484 33485 33486 33487

SHANK $\phi 3.0$
10 pcs./pack Rotary Rasps

Rough cutting

10,000 min⁻¹

33491 33492 33493 33494 33495

10 pcs./pack Rotary Files

Best surface finish

10,000 min⁻¹

33511 33512 33513

SHANK $\phi 3.0$
15 pcs./pack Assorted Set

Woodworking and Plastic Cutter Assorted Set ; 15 types ; Each types - pack 33521

33481	33486	33494
33482	33487	33495
33483	33491	33511
33484	33492	33512
33485	33493	33513

Tempered Steel Drills for plastics and woods. High Speed Steel Drills for steels and stainless steels, Carbide Drills for PCB, FRP.

SHANK $\phi 2.34$
12 pcs./pack Tempered Steel Drill (Total Length : 44 mm) : 15,000 min⁻¹

ϕ mm	ϕ mm		ϕ mm	ϕ mm		ϕ mm	ϕ mm	
0.5	8	36011	1.2	10	36018	2.3	12	36029
0.6	8	36012	1.3	10	36019			
0.7	8	36013	1.4	10	36020			
0.8	8	36014	1.5	10	36021			
0.9	10	36015	1.6	10	36022			
1.0	10	36016	1.8	12	36024			
1.1	10	36017	2.1	12	36027			

• $\phi 0.5$ ~ 2.3 mm each 1 pc. Full Size Set (No. 36011 ~ 36029 ; 15 pcs. - pack) ; Special case provided 36030

SHANK $\phi 2.34$
10 pcs./pack High Speed Steel (H.S.S) Drill (Total Length : 44 mm) : 20,000 min⁻¹

ϕ mm	ϕ mm		ϕ mm	ϕ mm		ϕ mm	ϕ mm	
0.5	9	36051	1.2	11	36058	1.9	12	36065
0.6	9	36052	1.3	11	36059	2.0	12	36066
0.7	9	36053	1.4	11	36060	2.1	12	36067
0.8	11	36054	1.5	12	36061	2.2	12	36068
0.9	11	36055	1.6	12	36062	2.3	12	36069
1.0	11	36056	1.7	12	36063			
1.1	11	36057	1.8	12	36064			

• $\phi 0.5$ ~ 2.3 mm each 1 pc. Full Size Set (No. 36051 ~ 36069 ; 19 pcs. - pack) ; Special case provided 36070

*Order in standard package quantities.

Diamond / CBN
Carbide Cutters
Specialty Tools
Mounted Points
Rubberized Abrasives
Flap Wheels
Polishing Brushes
Felt Bobs
Abrasive Compounds & Polishing Tools
NSK Exclusive Tools

Diamond / CBN
Carbide Cutters
Specialty Tools
Mounted Points
Rubberized Abrasives
Flap Wheels
Polishing Brushes
Felt Bobs
Abrasive Compounds & Polishing Tools
NSK Exclusive Tools

SPECIALTY TOOLS

SHANK $\phi 2.34$
10 pcs./pack Mandrels

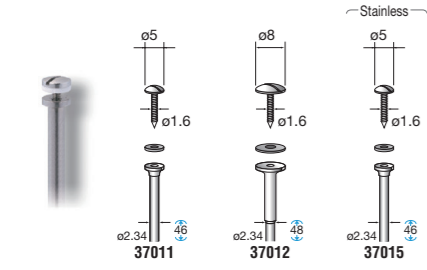

SHANK $\phi 3.0$
10 pcs./pack Mandrels

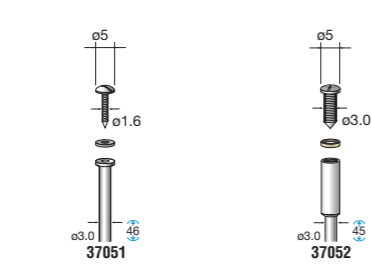

3 pcs./pack Mandrels

SHANK $\phi 6.0$
1 pc./pack Mandrels

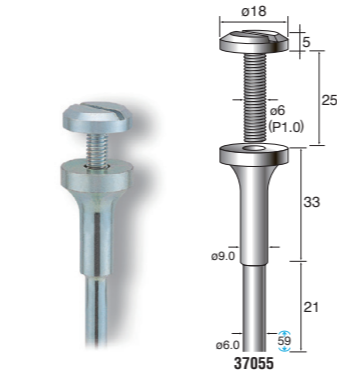

SHANK $\phi 2.34, \phi 3.0$
10 pcs./pack

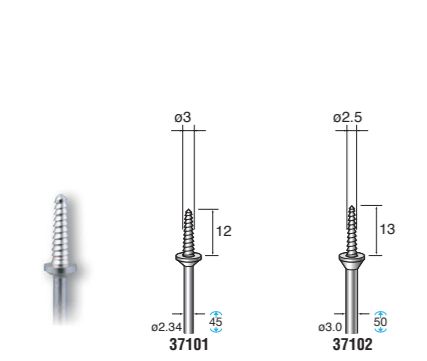

10 pcs./pack

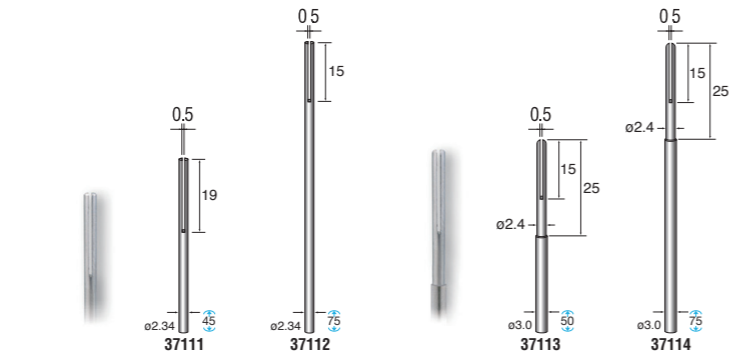

MOUNTED POINTS

Types of Abrasive Grain

"Abrasive Grain" is a general term of very hard abrasive particles for polishing and grinding. Abrasive Grain is harder than work materials and functions to grind work materials. Abrasive Grain is classified generally into three types.

Alumina type

Primary ingredient is alumina (aluminium oxide : Al_2O_3).

- A** : For rough grinding of iron and steel materials, low carbon steels, forged products, castings and raw steel materials.
- WA** : For general grinding of alloy steels, tool steels and carbon steels.
- PA** : For general grinding of heat treated alloy steels, tool steels, and stainless steels.

Silicon Carbide type

Primary ingredient is silicon carbide (SiC).

- C** : For general grinding of cast iron, chilled cast iron, copper, bronze, brass, aluminum and non ferrous metals.
- GC** : For general grinding of super hard alloys, ceramics, stone, jewelry, glass, pottery, wood and synthetic resins.

Mixed Abrasive Grain type

Mixed use of abrasive grain of the same type

- PA · W** : For precision grinding of high speed steel, alloy steels, tool steels and special alloys.
- A · WA** : For rough grinding of iron and steel materials, low carbon steels, forged products, castings, steel materials and stainless steels.

Bonding Material

Material used to bond and hold abrasive grains. Primary bonding materials are shown below.

- V (vitrified)** : Mainstream of magnetic bonding material, grinding stone
- B (resinoid)** : Bonding material is mainly made of thermosetting
- R (rubber)** : Hard rubber
- E (shellac)** : Thermoplastic resin (natural resin)

Hardness Grade

This shows bonding strength of abrasive grain, bonding materials and wear resistance of grinding stone. The Hardness Grade is measured by various instruments. The hardness is classified from A to Z, A is the softest while Z is the hardest.

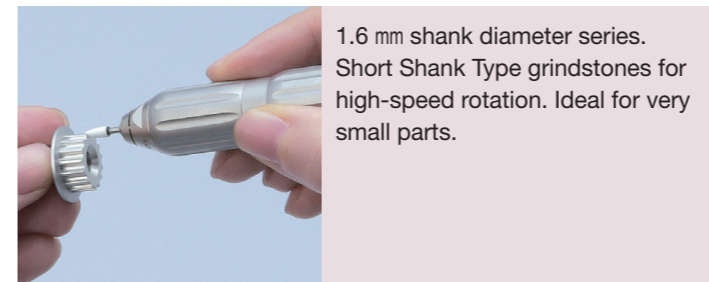
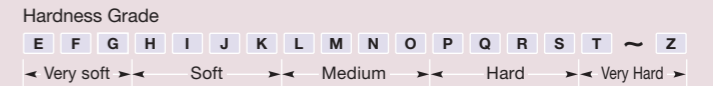

SHANK $\phi 1.6$

10 pcs./pack WA V P PINK

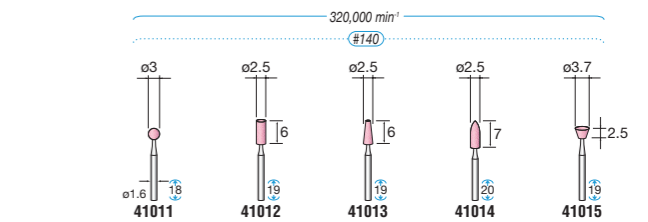

SHANK $\phi 1.6$

10 pcs./pack WA V P WHITE

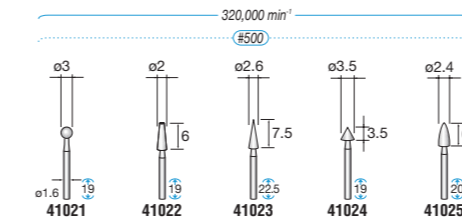

10 pcs./pack GC V M GREEN

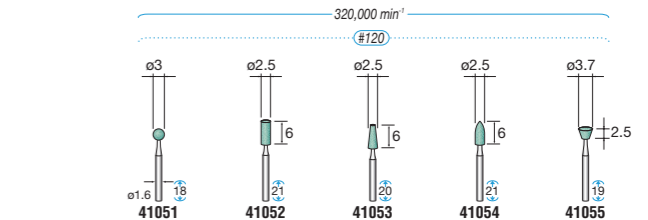

SHANK $\phi 2.34$

10 pcs./pack WA V P PINK

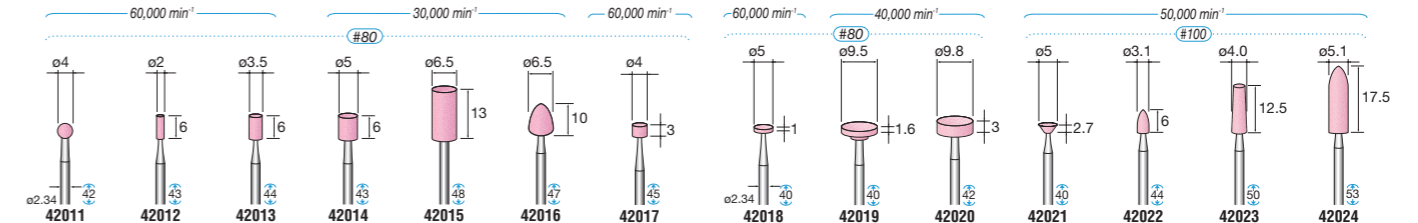

SHANK $\phi 2.34$

10 pcs./pack WA V P WHITE

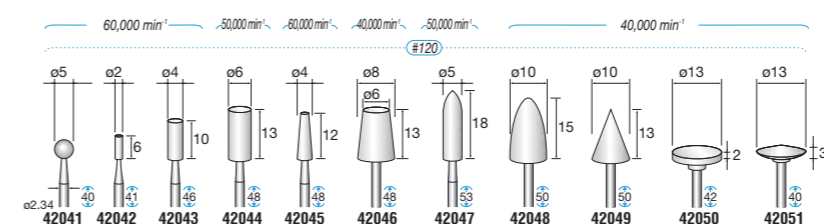

10 pcs./pack WA V P WHITE

